

*MX Missile Basing*

September 1981

NTIS order #PB82-108077



Library of Congress Catalog Card Number 81-600133

For sale by the Superintendent of Documents,  
U.S. Government Printing Office, Washington, D.C. 20402

## Foreword

This report, prepared at the request of the Technology Assessment Board, reviews the various ways in which the new MX intercontinental ballistic missile could be based, and assesses the technical issues, the advantages, and the disadvantages associated with each major option. In order to do so, OTA explored a wide variety of military technologies and issues, ranging from antiballistic missile defense to antisubmarine warfare to the impact of major construction projects on arid Western lands. OTA has made every effort to apply comparable assumptions and criteria to the various options assessed, and to be explicit about identifying questions which simply cannot be resolved on technical grounds alone. Our purpose is to assist Members of Congress in evaluating particular basing modes of interest to them, and to permit comparison of alternatives.

OTA identified a wide variety of possible basing modes and evaluated them in terms of: technical risk; degree of survivability; endurance; contribution to weapon effectiveness; effectiveness of command, control, and communications; arms control impacts; institutional considerations; impacts on the deployment region; costs; schedule; and impact on stability. The concluding section of chapter 1 compares the leading options in terms of a variety of criteria used, and it is apparent that a final choice depends in large measure on the relative weight assigned to these criteria. Five basing modes were found that appear feasible and offer reasonable prospects of survivability, but none of them is without serious risks, high cost, important uncertainties, or significant drawbacks. No basing mode appears likely to offer survivability for the MX much before the end of the current decade.

Much of the research done for this assessment required the use of classified sources. The material in this unclassified report is believed accurate, balanced, and complete but security requirements have at times made it necessary to omit some of the supporting technical analysis. OTA will shortly publish a classified annex to this report, which will be available to qualified requesters.

OTA is grateful for the assistance of its MX Missile Basing Advisory Panel, the cooperation of various components of the Department of Defense; the cooperation of the General Accounting Office, the Congressional Budget Office, and the Congressional Research Service; the assistance of other U.S. Government agencies; and the support of numerous individuals.

~ # d ~

JOHN H GIBBONS  
Director

# MX Missile Basing Advisory Panel

Harry Woolf, *Chairman*  
Director, Institute for Advanced Study

Stanley Albrecht  
Professor and Editor of *Rural Society*  
Department of Sociology  
Brigham Young University

Stephen T. Bradhurst  
Director  
Nevada MX Project Field Office

Russell E. Dougherty  
General, USAF (retired)  
Executive Director  
Air Force Association

Sidney D. Drell  
Professor and Deputy Director  
Stanford Linear Accelerator Center

Henry M. Foley  
Professor  
Department of Physics  
Columbia University

Kenneth E. Foster  
Associate Director  
Office of Arid Lands Studies  
University of Arizona

Sanford Gottlieb  
Kensington, Md.

Daniel O. Graham  
Lt. Gen., USA (retired)  
Director of Special Projects  
American Security Council

William Kincade  
Executive Director  
Arms Control Association

Gordon Kirjassoff  
President  
Edwards and Kelcey

Kenneth C. Olson  
Project Manager  
Utah MX Coordination Office

Kenneth Smith  
Lockheed Chief Engineer (retired)

John Toomay  
Major General, USAF (retired)

William Van Cleave  
Director  
Defense and Strategic Studies  
University of Southern California

Jerome Wiesner  
Institute Professor  
Massachusetts Institute of  
Technology

James R. Woolsey, Esq.  
Shea & Gardner

Note The Advisory Panel provided advice and comment throughout the assessment, but the members do not necessarily approve, disapprove, or endorse the report for which OTA assumes full responsibility

# MX Missile Basing Project Staff

Lionel S. Johns, *Assistant Director, OTA*  
*Energy, Materials, and International Security Division*

Peter Sharfman  
*Program Manager, International Security & Commerce Program*  
*Project Director (from January 1981 )*

Jeremy Kaplan *Project Director (to January 1981 )*

Ashton Carter      Forrest R. Frank\*      Antoinette Kassim\* \*  
Marc Messing\*      Theodore Postol \*      Robin Staff in

## *Administrative Staff*

Helena Hassell      Dorothy Richroath      Jackie Robinson

## *Contractors*

Abt Associates  
Booz-Allen & Hamilton, Inc.  
Lynda Brothers\*\*  
Energy and Resource Consultants, Inc.  
The Institute of Ecology  
Gerald Garvey  
Barbara M. Heller

Horizons Technology, Inc.  
Hydra Corp.  
John Muir Institute  
J. Watson Noah, Inc.  
Science Applications, Inc.  
Peter Zimmerman\* \*

# OTA Publishing Staff

John C. Holmes, *Publishing Officer*

John Bergling      Kathie S. Boss      Debra M. Datcher      Joe Henson

\* OTA contract personnel  
\*\*OTA consultant

# Contents

<i>Chapter</i>		<i>Page</i>
1.	Summary . . . . .	3
2	Multiple Protective Shelters . . . . .	33
3.	Ballistic Missile Defense . . . . .	111
4.	Launch Under Attack , . . . . .	147
5.	Small Submarine Basing of MX . . . . .	167
6,	Air Mobile Missile . . . . .	217
7.	Surface Ship Basing of MX . . . . .	235
8.	Land Mobile MX Basing. . . . .	257
9.	Deep Underground Basing . . . . .	269
10	Command, Control, and Communications (C') . . . . .	277
11,	Diversity of U.S. Strategic Forces . . . . .	303
12.	Arms Control Considerations and MX Basing Options . . . . .	311
 <i>Appendixes</i>		
A.	Letter of Request . . . . .	325
B.	MX Missile ... . . . .	328
C.	Acronyms and Glossary . . . . .	330

**Chapter 1**  
**SUMMARY**

## Chapter 1.—SUMMARY

	Page
Introduction .....	3
Principal Findings .....	4
Eleven Possible Basing Modes .....	8
1. MX/MPS— The Current Baseline System .....	8
2. MX/MPS: Vertical Shelters .....	14
3. Valley Cluster Basing .....	14
4. Split Basing MPS: Nevada/Utah and West Texas/New Mexico .....	15
5. MX/MPS With a LoADS ABM System .....	15
6. MPS Deployment of Minuteman III .....	17
7. Launch Under Attack .....	18
8. Silo-Basing With an ABM Defense .....	19
9. Basing on Small Submarines .....	20
10. Surface Ship Mobile .....	22
11. Air Mobile .....	23
Comparison of Basing Modes .....	24
Technical Risk .....	24
Survivability .....	25
Endurance .....	25
Weapon Effectiveness .....	25
Command, Control, and Communications (C <sup>3</sup> ) .....	26
Arms Control Considerations .....	26
Institutional Constraints .....	26
Impacts on the Physical Environment .....	27
Socioeconomic Impacts .....	27
Costs .....	27
Schedule .....	28
Stability .....	29

### TABLE

	Page
1. Summary, Lifecycle Cost Estimates for Basing Options .....	27

### FIGURES

	Page
1. MX Missile Characteristics .....	3
2. Conceptual Cluster Layout .....	8
3. MPS Shelter Requirement .....	10
4. Potential Vegetative Impact Zone .....	12
5. LoADS Defense Unit After Breakout .....	16
6. Attack Timeline .....	18
7. Conceptual Submarine-Launch MX Missiles .....	20
8. Survivability v. Escape Time .....	23



## INTRODUCTION

The U.S. Air Force is developing a new intercontinental ballistic missile (ICBM) known as the MX (fig. 1). Because the hardened "silos" in which existing ICBMs are based are considered increasingly vulnerable to a Soviet attack as a result of the improving accuracy of Soviet missiles, Congress and the Department of Defense (DOD) have agreed that a more survivable mode than hardened silos should be found for basing any new missile. OTA has examined a variety of ways in which such a missile could be based,

The purpose of this study is to identify MX basing modes and to assess the major advantages, disadvantages, risks, and uncertainties of each. At the outset of this study, OTA

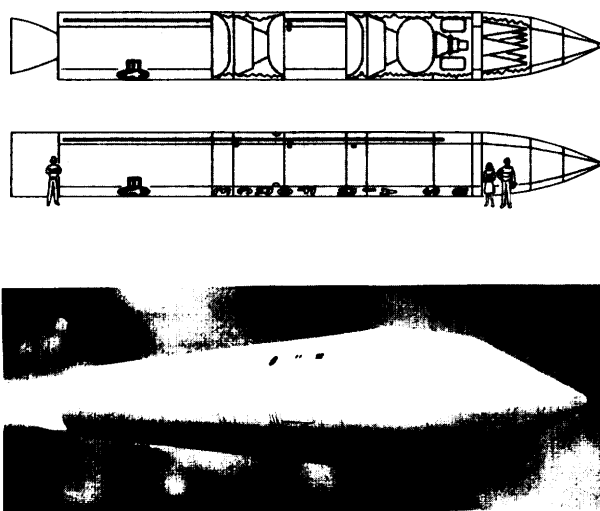
reviewed all the basing modes that could be identified, including those addressed in past DOD studies. On the basis of criteria of technical feasibility and the likely ability of each basing mode to provide survivability against a range of plausible Soviet threats, the list was narrowed to 11 basing modes that were analyzed in detail. This report presents these analyses, and also states briefly why other possibilities were rejected. Detailed analyses narrowed the range to five possibilities:

1. multiple protective shelter (MPS) basing in several variants,
2. antiballistic missile (ABM) defense of MPS basing,
3. launch under attack,
4. basing on small submarines, and
5. basing on large aircraft.

There is a variety of criteria against which these basing modes can be evaluated, though there is no general agreement about their relative importance. Indeed, since no basing mode ranks highest against all the commonly used criteria, deciding how to choose and weigh the criteria of evaluation is the essence of choosing a basing mode. To help Members of Congress assign the most weight to those criteria they consider most important, OTA has compared these five basing modes separately against these criteria in the last section of this summary chapter.

OTA was requested by the Technology Assessment Board to examine only basing modes for the MX missile. For this reason, the analysis does not address the questions of whether and why the missile itself is needed, or the relative merits of deploying additional numbers of existing Minuteman III or Trident I missiles. During the course of the study the Board requested that an analysis of rebasing the existing Minuteman III missiles in MPS to increase their survivability be included. Since the large size of the MX missile limits the ways in which it could be based, OTA surveyed bas-

Figure 1.—MX Missile Characteristics



### Missile Description

Length	71 feet
Diameter	92 Inches (7 feet 8 Inches)
Gross weight	152,000 lbs
Number of reentry vehicles	10

SOURCE Office of Technology Assessment

ing modes that might be used for smaller missiles, but found none so attractive as to lead us to seek a change in our terms of reference. It is important to note that much of OTA'S analysis is premised on the accuracy of U.S. intelligence about the capabilities and growth of Soviet strategic forces. Due to the study boundaries, OTA'S criteria of analysis and comparison tend to use, rather than critically evaluate, conventional wisdom about how strategic nuclear forces support U.S. national security.

OTA does not have a recommendation as to which basing mode, or combination of basing

modes, Congress should choose. OTA is therefore able to present the relevant technical information regarding each possibility without the need to make and defend a choice. This study provides data, analyses, and explanations that will assist Congress to understand and evaluate the forthcoming Reagan administration proposal, whether this proposal turns out to be a reaffirmation of the existing program as shaped by the Carter administration, a relatively minor modification, or a major change in direction.

## PRINCIPAL FINDINGS

**1. There are five basing modes that appear feasible and offer reasonable prospects of providing survivability and meeting established performance criteria for ICBMS.** They are: 1) MPS basing of the type now under development by the Air Force or in one of several variants. MPS basing involves hiding the missiles among a much larger number of shelters, so that the Soviets would have to target all the shelters in order to attack all the missiles. If there were more shelters than the Soviets could effectively target, then some of the missiles would survive. This approach was the choice of the Carter administration, and one variant of MPS is now under engineering development by the Air Force. 2) MPS basing defended by a low-altitude ABM system known as LoADS (Low Altitude Defense System); 3) reliance on launch under attack so that the missiles would be used before the Soviets could destroy them; 4) basing MX on small submarines; and 5) air-mobile basing in which missiles would be dropped from wide-bodied aircraft and launched while falling. As described below, each of these alternatives has serious risks and drawbacks, and it is believed that choosing which risks and drawbacks are most tolerable is a judgment that cannot be made on technical grounds alone.

**2. No basing mode is likely to provide a substantial number of survivable MX missiles much before the end of this decade.** While some basing modes would permit the first missiles to be operational as soon as 1986 or 1987, these missiles could not be considered more survivable than the existing Minuteman missiles until additional elements of the basing system were in place.

**3. MPS basing would preserve the existing characteristics and improve the capabilities of land-based ICBMS, but has three principal drawbacks.**

- **MX missiles based in MPS would provide better accuracy and endurance, and comparable responsiveness, time-on-target control, and retargeting capability, when compared to other feasible basing modes.**
- Survivability depends on what the Air Force calls "preservation of location uncertainty" (PLU), that is, preventing the Soviets from determining which shelters hold the actual missiles. PLU amounts to a new technology, and while it might well be carried out successfully, **confidence in PLU will be limited until prototypes have been successfully tested.** Even then lingering doubts might remain.

- MPS basing cannot ensure the survivability of the missiles unless the number of shelters is large enough relative to the size of the Soviet threat. **The “baseline” system of 200 MX missiles and 4,600 shelters would not be large enough if the Soviets chose to continue to increase their inventory of warheads.** If the trends shown in recent Soviet force modernization efforts continue into the future, an MPS deployment of about 350 missiles and 8,250 shelters would be needed by 1990 to provide survivability. Although the number of missiles and shelters needed depends on what the Soviets do, the leadtimes for construction are so long that decisions on size must be made before intelligence data on actual, as distinct from possible, Soviet programs are available.
  - **MPS would severely impact the socioeconomic and physical characteristics of the deployment region.** At a minimum, the deployment area would suffer the impacts generally associated with very rapid population growth in rural communities; but larger urban areas would also be affected by economic uncertainties regarding the size of the MPS construction work force and its regional distribution. The physical impacts of MPS would be characteristic of the impacts of major construction projects in arid regions; but because the grid pattern of MPS would mean that a very large area would be close to construction activities, it is possible that thousands of square miles of rangeland could be rendered unproductive.
4. **None of the variants of MPS would reduce the risks and uncertainties associated with PLU or significantly alter the number of shelters required. However, split basing or the selection of a different deployment area would mitigate the regional impacts.** The variants that OTA examined include changes from horizontal to vertical shelters, from “individual cluster” to “valley cluster” basing, and from Utah/Nevada basing to basing divided between Utah/Nevada and west Texas/New Mexico. A further variant

would be to construct additional silos in the existing Minuteman basing areas to create a Minuteman/MPS system. This construction would be substantially cheaper than the proposed MX/MPS system, but would not be significantly quicker to construct.

5. **A LoADS ABM system could effectively double the number of shelters in an MPS deployment provided two conditions were met.** A LoADS system would have a high probability of shooting down the first Soviet warhead aimed at each MX missile, forcing the Soviets to attack each shelter with two warheads. The conditions for LoADS’ effectiveness are: 1) PLU both for the MX and for the LoADS defense unit, and 2) survival and operation of the defense in the presence of nearby nuclear detonations. Since the LoADS defense unit must be concealed in a shelter and must be indistinguishable from the missiles and the decoys, LoADS deployment would compound the difficulties of PLU. These difficulties would be greater still if the LoADS addition were not planned at the time the MPS system was being designed. The LoADS defense unit would be required to endure nuclear effects of a severity unprecedented for so complex a piece of equipment.

A LoADS deployment would require the United States either to seek amendment of, or to withdraw from, the ABM Treaty reached at SALT 1.

6. **Basing MX missiles in silos and relying on launching the missiles before a Soviet attack could destroy them (launch under attack, or LUA) would be technically feasible, but it would create extreme requirements for availability of, and rapid decisionmaking by, National Command Authorities.** A substantial upgrading of existing warning and communications systems would be required to ensure this capability against a determined Soviet attempt at disruption. Reliance on this capability would, however, impose extremely stringent requirements that the President be in communication with both the warning systems and the forces, and that an unprecedentedly weighty decision be made in a few minutes on the basis of information sup-

plied by remote sensors. Finally, there would always be concern about whether the system was really immune to disruption or errors.

**7. MX missiles based on small submarines would be highly survivable. Submarine-based MX would not be significantly less capable than land-based MX, but submarine-basing would involve a reorientation of U.S. strategic forces.** An MX force based on small diesel-electric or nuclear submarines operating 1,000 to 1,500 miles from the U.S. coast could offer weapon effectiveness (i. e., accuracy, responsiveness, time-on-target control, and rapid retargeting) almost as good as land basing and would probably be adequate to carry out any strategic mission. A command, control, and communications (C<sup>3</sup>) system to support submarine basing would be different from that used for landbasing but would not necessarily be less capable. However, submarine basing of MX would change the relative importance of land- and submarine-based strategic forces. Although OTA could find no scientific basis for predicting such an occurrence, the possibility cannot be excluded that an unexpected Soviet capability in antisubmarine warfare that threatened the U.S. force of Poseidon and Trident submarines might also threaten a force of MX missiles on small submarines. The cost of providing 100 MX missiles on alert at all times on a small submarine force would be roughly comparable to the cost of the baseline MPS system, and would be less than the cost of an MPS system sized to meet a larger Soviet threat. A significant problem is that such a force of small submarines could not be constructed quickly; existing U.S. submarine construction programs are already behind schedule, and delays might arise from using shipyards which are not now building submarines. It is therefore unlikely that initial MX deployment on small submarines could take place before 1990. However, the first MX missiles deployed would be survivable even before the rest of the deployment was complete.

**8. An air-mobile MX-carried on wide-bodied aircraft and launched in midair—would be survivable provided the aircraft received timely warning and took off immediately.** Its dependence on

prompt response to timely warning of submarine-launched ballistic missile attack would give such a force a common failure mode with the bomber force. (Removing dependence on warning by means of continuous airborne alert would be prohibitively expensive; acquisition and "10 years of operation for such a force could cost \$80 billion to \$100 billion (fiscal year 1980 dollars). ) On the other hand, an air mobile force could not be threatened by the Soviet ICBM force unless the Soviets deployed man)' more ICBM missiles than they now possess and used them to barrage the entire Central United States. The outcome of such an attack would be insensitive to Soviet improvement in the fractionation and accuracy of their ICBMS. An air mobile MX force could not endure long after an attack if the Soviets attacked every airfield on which such planes could land to refuel. In this case, the National Command Authorities would have to "use or lose" the MX missiles within 5 to 6 hours of a Soviet attack. Providing endurance by increasing the number of airfields at which the planes could refuel would be enormously expensive (\$10 billion to \$30 billion for up to 4,600 airfields), and growth of the Soviet threat to plausible levels for the 1990's would require so many airfields that they would essentially fill the continental United States. The aircraft would have to take off to launch their missiles, which could mean slow response time, longer warning for the Soviets of a U.S. strike, and the possibility that the Soviets would mistake dispersal during a crisis for preparation for a U.S. first strike. Warning, communications, and guidance systems for an air-mobile force could be complex.

**9. The problems associated with other basing modes studied by OTA appear more substantial.**

An ABM defense of MX missiles based in fixed silos against a large Soviet threat would require the use of a complex system based on frontier technology and potentially vulnerable to Soviet countermeasures. The technical risks appear too high to support a decision today to rely on such a system for MX basing. Basing MX on surface ships appears to offer no serious advantages and significantly less survivability than submarine basing. Basing MX in

“superhardened” shelters (e. g., very deep underground) would likely involve a period of several days between a launch order and the actual launch of the missile. Rail mobile MX would involve problems of force management and vulnerability to peacetime accidents or sabotage. Road-mobile basing appears infeasible because of the size of the missile; off-road mobile basing appears to offer few advantages and several drawbacks compared to MPS.

**10. In comparing MPS, MPS with LoADS, LUA, small submarine basing, and air mobile, it is found that:**

- All offer reasonable prospects for feasibility and survivability. MPS depends for survivability on concealing its location (PLU) which creates a degree of technical risk, and which would become still more difficult if LoADS is used to defend MPS.
  - All are compatible with high weapon effectiveness for the MX missile, although MPS, MPS with LoADS, and LUA would provide slightly better accuracy than submarine basing or air mobile.
  - MPS would endure in an operational condition for a long time if it survived; small submarines would endure for several months; air mobile might endure for only a few hours, depending on the nature of the Soviet attack; the endurance of LoADS would depend on the speed and effectiveness of surviving Soviet reconnaissance and retargeting capabilities; LUA would have no endurance at all.
  - All are compatible with adequate C<sup>3</sup>, but obtaining such C<sup>3</sup> for any of them would require time, effort, and money.
  - MPS could complicate future arms control. MPS with LoADS would require amending or withdrawing from the ABM Treaty reached at SALT 1. LUA, small submarines, and air mobile appear compatible with existing arms control concepts.
  - MPS, or MPS with LoADS, would have an impact on both the socioeconomic and physical environment in the deployment region that would be so great as to be different in kind from the impacts of any of the other systems. LUA would have virtually no environmental impact. Impacts from submarine basing and air mobile would be relatively small and limited to the areas of the operating bases,
- Assuming a requirement for 100 surviving MX missiles, costs of baseline MPS, submarine basing, and air mobile would be roughly comparable: costs of acquisition and 10 years of operations for nominal designs are estimated to be roughly \$40 billion (fiscal year 1980 dollars). Rebasement of Minuteman III in an MPS mode would cost 10 to 20 percent less. Growth in the Soviet threat would require increases in the costs of MPS systems, but not in the others. If the Soviet threat grew to a level OTA considers plausible for 1990, the United States could assure survivability of the MX/MPS either by adding LoADS (at an additional cost of \$10 billion to \$15 billion) or by expanding the number of shelters and MX missiles (at an additional cost of \$15 billion to \$20 billion). Continued growth of the Soviet threat into the 1990's would drive the cost of survivability as high as \$80 billion. Costs of LUA would be the lowest: procurement of the MX missiles, modification of existing silos, and upgraded C<sup>3</sup> and warning systems could be \$20 billion cheaper than the alternatives.
  - MPS could provide a small, non-survivable force by 1986 or 1987, and a large, survivable force by about 1990. MX deployment relying on launch under attack could begin in 1986, but completion of necessary upgrading of warning and C<sup>3</sup> systems would require several years longer. Air mobile could be deployed near the end of the decade. MPS with LoADS could be available around 1990. Small submarines could be deployed beginning around 1990, and would be survivable immediately. Thus, none of the basing modes could close the so-called “window of vulnerability” before the end of the decade,

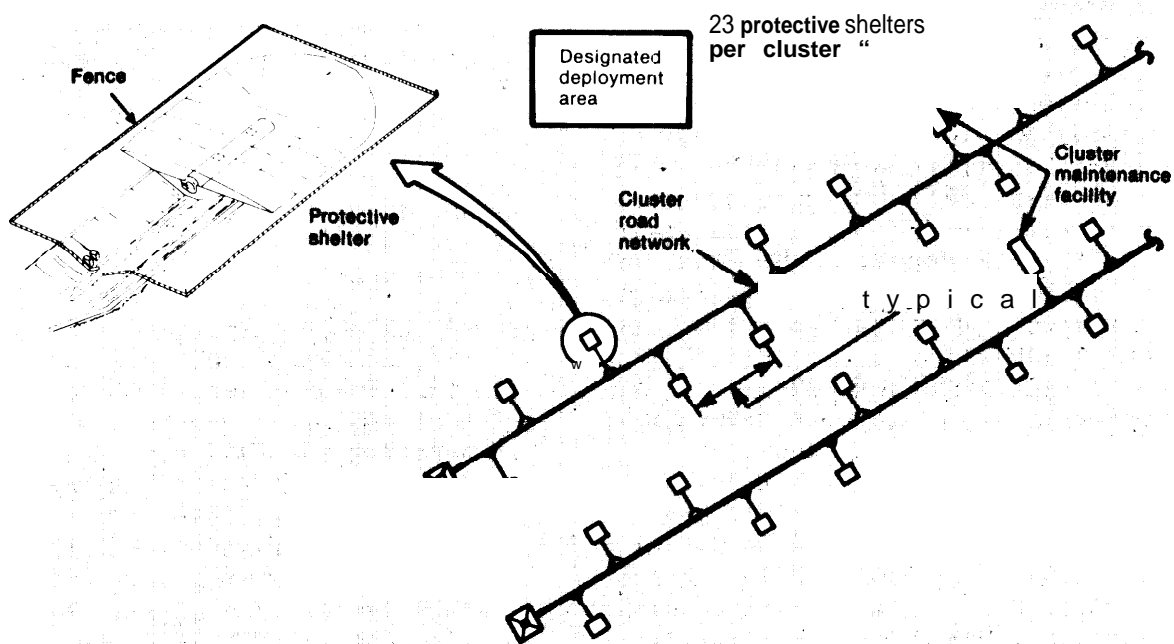
## ELEVEN POSSIBLE BASING MODES

### 1. MX/MPS—The Current Baseline System

In the fall of 1979, the Carter administration selected a basing mode for MX and decided to proceed with full-scale engineering development. This design envisages the deceptive deployment of 200 MX missiles in 4,600 hardened concrete shelters. If the Soviets could not know which shelters contained the actual MX missiles and which contained missile decoys, they would have to target all 4,600 shelters in order to attack all 200 missiles. The baseline system would be located in the Great Basin area of Nevada and Utah and could be expanded by building additional shelters, additional missiles, or both.

The shelters would be spaced roughly 1 mile apart, and arranged in a linear grid pattern. (Fig. 2 illustrates the schematic layout of a single cluster.) Each of the 200 missiles would be based in separate clusters of 23 shelters. The missiles would be transportable within each cluster but could not be moved from one cluster to another without removing large earthen barriers. Each shelter would resemble a garage or loading dock; the truck transporting a missile or decoy would back up to the shelter entrance, and insert the missile or decoy horizontally. Each cluster would thus contain 1 MX missile, 22 decoys, 23 shelters, 1 large transporter truck, and 1 maintenance facility. The truck would shuffle the missile and the decoys among the shelters in such a

Figure 2.—Conceptual Cluster Layout



way that the Soviets would be unable to determine which shelter contained the missile. Missiles would also be transported for maintenance or, possibly, to facilitate arms control verification.

The MX missile in MPS basing has been designed to set a new standard in military capability. Its accuracy would be unprecedented. It could be rapidly retargeted in a variety of ways, and would have precise time-on-target control. MPS basing would give MX a very high alert rate and a long postattack endurance. As a system, MX/MPS would perform its military function providing that two conditions were met: 1) preservation of location uncertainty for the missile, and 2) adequate size to meet the Soviet threat.

#### Preservation of Location Uncertainty (PLU)

The multiple shelters cannot ensure survival of the requisite number of missiles if the Soviets find out which shelters contain the missiles. PLU therefore involves making certain that the observable characteristics of missiles and decoys are so nearly identical that an outside observer cannot distinguish them. This design entails a major new engineering task, driven by the high sensitivity of present-day and future sensors and by the many observable signs of the missile's presence. As an example of PLU engineering, the missile decoy might contain an appropriate quantity and distribution of high-permeability metal to help make it impossible to distinguish the missile from the decoys by means of a metal detector.

Dealing with this and dozens of other potentially observable signatures makes PLU the equivalent of a new technology, which is wide in scope and intensive in detail. It would require the integration of administrative, operational, and technical considerations. One cannot have confidence in the success of this "new technology" before equipment prototypes are field-tested, because even fine details of missile signatures are important for adequate missile concealment. Furthermore, after the system is fully designed, tested, and deployed, lingering doubts could remain that would limit confi-

dence in the system. Even small doubts could be important, since a catastrophic breakdown in PLU (e. g., a technique whereby the Soviets could determine the exact location of the missiles by satellite observations) would make it relatively easy to attack all the MX missiles; a more limited breakdown, while not imperiling the entire system, could improve the effectiveness of a Soviet attack and reduce the weight of a U.S. retaliation. On the other hand, the Soviets' task of "breaking" PLU could be difficult as well. For the Soviets to attack the system on the basis of their own counter-PLU efforts might entail considerable risk and uncertainty on their part.

Except during missile transport, the proposed baseline system would not restrict public activities outside the 2.5-acre sites surrounding each shelter. While barring the public from a larger area might be infeasible, restrictions on public activities, including mineral exploration and development, could be necessary. From a technical standpoint, the nature and extent of these restrictions depends on the degree of success of the Air Force PLU program.

#### Adequate Size in the Face of Threat Growth

The principle of an MPS system is that survivability is maintained by having more shelters than the enemy is able to target. It is therefore necessary to estimate the number of RVS (reentry vehicles carrying a nuclear warhead) which the Soviets could use to attack the MX/MPS system, and to ensure that the number of shelters is sufficiently large. Since the Soviets have other high-priority targets (bomber bases, submarines in port, etc.) and presumably want to retain a force in reserve, the number of RVS available to attack MX would be somewhat less, perhaps several thousand RVS less, than the total number of Soviet RVS.

Any effort to estimate the size of and composition of future Soviet forces is highly uncertain—U.S. intelligence is far from perfect, and in some cases the Soviet leaders themselves may not yet have made key deci-

sions. OTA has sought an approximation of the threat by making a series of conservative assumptions, most notably that the trends of the 1970's in the rate of Soviet development and deployment of their ICBM force continue through the 1980's and the 1990's. On this assumption, it is estimated that the Soviets could have 6,000 to 7,000 RVS available to attack MX/MPS by 1990, and 11,000 to 12,000 RVS available by 1995. By the year 2000, 15,000 or more Soviet RVS could be aimed at an MX/MPS deployment. This assumes that approximately 3,000 additional Soviet RVS would be reserved for other counterforce targets, such as Minuteman silos, and that an additional force of Soviet strategic weapons would be allocated to attack or threaten U.S. cities, industry, and conventional military forces.

One can calculate the approximate number of shelters needed to ensure the survival of 100 MX missiles against the projected Soviet threat (fig. 3). For example, if we assume the 1990 threat of 7,000 RVS targeted against MX, an 85-percent probability of RVS reaching their targets, a deployment of 1 missile for each 23

shelters, and no ballistic missile defense, then this would require a deployment of 360 missiles among 8,250 shelters. Similarly for the 1995 threat of 12,000 RVS, the same survival requirement could be met with 550 MX missiles among 12,500 shelters.

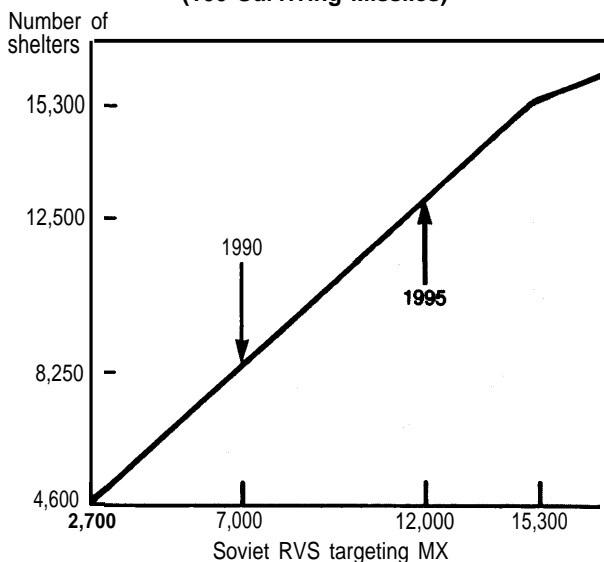
An alternative assumption is that, faced with the threat that MX would pose to their silos, the Soviets would devote their efforts to providing survivable basing for their existing ICBM force, rather than to expanding their RV inventory in order to attack MX/MPS.

The existing schedule for the baseline case calls for completion of 4,600 shelters by 1989, although it does involve some optimistic assumptions. Continuation of the planned construction rate (roughly 100 shelters per month) would mean that it would be 1992 before the level of 8,250 shelters was approached, and by then 8,250 could be insufficient. By 1995 the number of shelters constructed (at a rate of 100 per month) would be just under 12,000 — still somewhat less than the number of available Soviet RVS. Clearly, a response to a Soviet effort to overwhelm MX calls for either an ABM system (discussed below) or a higher construction rate.

A large MPS system which was too small to retain survivability could still have some value as a means of limiting Soviet options. It would still oblige the Soviets to use a large fraction of their strategic forces to destroy a somewhat smaller fraction of U.S. strategic forces. However, if the Soviets "fractionate" — i.e., put a larger number of smaller warheads on their large missiles — then the Soviets might be willing to accept an unfavorable exchange ratio because they could "afford" to expend a large number of RVS in order to destroy a smaller number of RVS that constituted the entire U.S. ICBM inventory. In any case, it is clear that an MPS that was far too small, say half as many shelters as available Soviet RVS, could not be considered at all survivable, and would be of little greater value than single shelter basing.

With the same reasoning, an MPS system that requires a number of years to build would

**Figure 3.— MPS Shelter Requirement  
(100 Surviving Missiles)**



Assumptions:  
 • 1 missile for every 23 shelters  
 • Damage expectancy 0,85  
 • Feasible Soviet threat growth

SOURCE Office of Technology Assessment



not reach survival value until the number of operational shelters exceeded the number of Soviet RVS available to attack them. If one assumes that the number of available Soviet RVS may grow from year to year, then the time when U.S. MPS construction actually began and the rate at which shelters were constructed would both be critical. Since building additional shelters would require time, including time to plan the additional building program, the United States would require a prediction several years in advance of the size of the Soviet threat against MX.

The Air Force has estimated that a construction rate of 2,000 shelters per year (about 165 per month) would not exceed projected construction resources, although there would be an additional \$400 million in front-end costs (e.g., additional cement factories). Assuming this construction rate, to start construction in 1986 would bring the United States to the required shelter level sometime in 1991, and it might not be difficult to stay ahead thereafter. However, it would be necessary to decide by 1983 (or 1984 at the latest) that a 2,000 shelter per year construction rate would be needed, and it is not clear that by 1983 the United States will have a reliable estimate of the path that Soviet ICBM deployment will have taken by 1990. Furthermore, the United States could not first build a 4,600-shelter system and then decide to expand it if it proved to be too small, unless the United States were prepared to defer survivability into the mid-1990's. Therefore, the completion date, size, regional impact, and cost of an MPS system would all depend in part on what the Soviets chose to do, and on the accuracy of the U.S. estimates of future Soviet programs.

It is possible that the Soviet decision about whether to attempt to overwhelm MX/MPS with large numbers of RVS would depend on Soviet estimates of their chances for success. U.S. construction of MX/MPS at the baseline rate might tempt the Soviets to deploy more RVS in order to "stay ahead," while a U.S. decision to build a larger deployment at an accelerated rate might persuade the Soviets that deploying many more RVS was pointless. In

this case, the expansion of the program would make itself unnecessary, but the United States would probably realize this only after incurring the greatly increased costs and regional impacts of expansion.

### Regional Impacts

The regional impacts of the proposed MPS basing system would be severe and could include the long-term loss of thousands of square miles of productive range lands. However, the severity of these impacts would result as much from the site selection criteria as from the nature of the basing system and could be mitigated, in part, by variants of the proposed system.

MPS construction would require a work force ranging in size anywhere from 25,000 to 40,000, depending on construction techniques, program decisions, and the total number of shelters required by 1990. The total associated population could be as high as 250,000 people. Because MPS siting criteria require minimum population densities, this influx of people would necessarily overwhelm the social infrastructure and severe impacts would result within the deployment area. The overall impacts would include potential economic benefits; but experience with rapid growth throughout the West suggests that most of these benefits would go to in-migrants with specialized skills, while unemployed residents of the deployment area, women, minorities, and Indians would be least likely to benefit. At the same time, the economic restructuring of the region would adversely impact many local businesses. The cultural values of isolated communities with integrated social structures would also be subject to severe disruption.

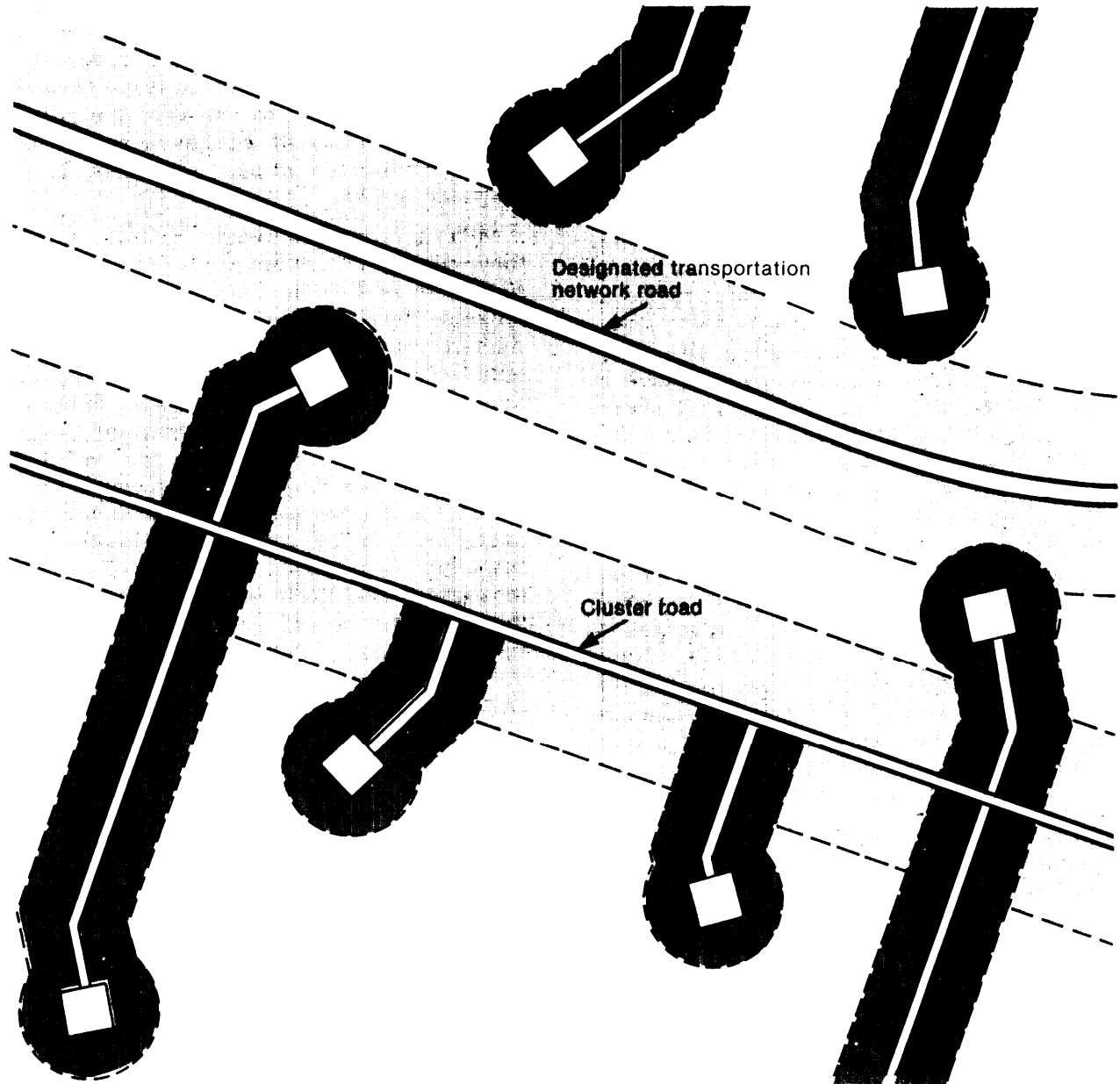
In the larger urban areas on the periphery of the deployment area, MPS would have different effects. Although these areas might have sufficient social infrastructures to absorb rapid population growth, uncertainties regarding the potential size of the MPS related population increase and their geographic distribution would preclude effective growth manage-

ment. As a result, investment planning in both the public and the private sectors would probably fail to minimize the adverse impacts or maximize the potential benefits of MPS deployment. Finally, smaller communities affected by planned energy developments in surrounding areas could be impacted by MPS if

the resource and manpower requirements contribute to delays in energy project schedules.

The physical impacts of MPS would necessarily involve the disruption of 200 square miles of land area for construction of shelters, roads, and support facilities (fig. 4). In a

Figure 4.— Potential Vegetative Impact Zone



SOURCE Office of Technology Assessment

deployment area with moderate rainfall and agricultural productivity, the major impacts of construction might be confined to the loss of those lands and related wildlife habitat, but other lands temporarily disturbed by construction activities probably could be revegetated. In "least productive" agricultural lands such as the Great Basin, however, the arid environment would inhibit revegetation and effects could spread to adjacent lands. In the absence of irrigated revegetation, or if subjected to continued disruption from PLU surveillance activities and random off-road vehicles, these lands would not recover. Consequently, thousands of square miles of productive rangeland could be desolated and the ecology of the entire region irreversibly degraded.

Institutionally, the use of Federal lands would raise many complicated questions of landrights, oil and gas leases, mining claims, grazing permits, and Indian land claims, resulting primarily from potential conflicts between PLU requirements and economic activities such as mineral exploration and development. If private lands are used, most of these questions could be circumvented by negotiation of easements with explicit provisions for PLU, definitions of compatible land uses, and covenants regarding the resale of properties and rights, although the process of negotiation might delay the project schedule.

#### Civilian Fatalities

OTA arranged for calculations of the number of civilian fatalities due to radiation fallout that would result from a Soviet nuclear attack on an MPS deployment in Utah and Nevada. The results depend to a very large degree on windspeed and direction, causing calculated fatalities to range from less than 5 million to more than 20 million. However, it seems quite probable that a Soviet nuclear attack on MX would be likely to include Minuteman and Titan missile fields, strategic bomber bases, and submarines in port. Because these existing targets are distributed over a large area, the added fallout-related fatalities due to the additional targets in the MPS fields would have a likely range from less than 1 million to 5

million. Total fatalities for this general attack have been estimated to range from 25 million to 50 million people.

Fatalities due to fallout would be a major part, but not the only measure, of damage caused by a nuclear attack. For a discussion of other consequences, and of the uncertainties involved, see OTA'S earlier study, *The Effects of Nuclear War*.

#### COST

All present cost estimates must be qualified; apart from the usual uncertainties of estimating future costs of unprecedented programs (which means that all estimates have at least a 10-percent error factor), there are some design decisions that have not yet been made that would have an impact on costs. Nevertheless, OTA reviewed the Air Force cost estimates and prepared an independent estimate using a comparable methodology. OTA'S estimate of \$37.2 billion (fiscal year 1980 dollars) for acquisition costs of the system is within 10 percent of the Air Force estimate of \$33.8 billion (fiscal year 1980 dollars) and is within the accepted range of uncertainty. In order to permit fair comparison with other possible basing modes, an estimate was made for the cost of: (a) acquisition plus (b) operating costs between initial operating capability (IOC) and final operating capability (FOC), plus (c) the cost of operating the full system for 10 years after FOC. This 10-year lifecycle cost was \$43.5 billion (fiscal year 1980 dollars). Note that neither the Air Force estimate nor the OTA estimate includes the costs of mitigating regional impacts. The socioeconomic impacts could amount to several billion dollars, which would be divided in some way among the Air Force, local and State governments, and individuals and firms in the area. The costs of irrigation to permit revegetation, if this were undertaken, could be several billion additional dollars.

OTA also estimated the cost of an expanded system. The estimated cost of a system of 8,250 shelters and 360 missiles, completed by 1990 is \$62.4 billion (fiscal year 1980 dollars).

The cost of a system of 12,500 shelters and 550 missiles, completed by 1995, was estimated at \$82.6 billion (fiscal year 1980 dollars).

At the request of the Senate Appropriations Committee, the Congressional Budget Office (CBO) made similar estimates. Their assumptions were coordinated with OTA, but they made use of an Air Force parametric cost model. CBO estimates of system acquisition costs for 325 missiles in 8,570 shelters (the least costly mix for the 1990 threat) were \$49 billion (fiscal year 1980 dollars), compared to OTA'S estimate of \$52.9 billion for acquisition costs. For the 1995 OTA projected threat, CBO estimated a system acquisition cost for 410 missiles and 13,510 shelters (the least costly mix) of \$66 billion (fiscal year 1980 dollars), compared to OTA'S estimate of \$71.1 billion for acquisition costs. CBO further estimated that if a LoADS ABM system were deployed to meet the 1990 threat, system acquisition costs for 225 missiles, 5,370 shelters, and 225 LoADS defense units (the least cost mix) would be about \$44 billion (fiscal year 1980 dollars), or about 10-percent less than an undefended system for the same threat level.

## Schedule

The present Air Force schedule calls for IOC in mid-1986, and FOC by the end of 1989. OTA reviewed the milestones which this schedule would require, and believes that the schedule for IOC, while possible, is quite optimistic. Any unforeseen delays, including delay in a firm administration decision on MX basing mode after July 1, 1981, would almost certainly result in slippage in IOC. On the other hand, a delay of some months in IOC need not lead to a corresponding delay in FOC. Slippage in IOC by 1 year, without significant change in FOC, would increase acquisition costs by about \$1 billion (fiscal year 1980 dollars). OTA considers this a likely scenario.

## 2. MX/MPS: Vertical Shelters

There is technical disagreement over whether MPS should have horizontal or vertical shelters. On the one hand, if missiles need

to be quickly relocated, it appears that missile relocation takes less time with horizontal shelters than with vertical shelters because missile insertion for horizontal shelters is somewhat simpler. On the other hand, the United States has more experience with, and understanding of, vertical shelters; and pound for pound of concrete, vertical shelters are more resistant to nuclear weapon effects than horizontal shelters. As a result, less land area might be required for a given number of shelters. Still, it appears that with adequate field tests, horizontal shelters could be built to withstand the expected nuclear environment with confidence.

There is no particular reason to believe that PLU, arms control verifiability, or addition of an ABM system would be significantly easier or more difficult if a shift were made from horizontal to vertical shelters. However, about a year of intensive engineering development has taken place on the basis of a decision to use horizontal shelters. Much effort has gone into design of PLU and ABM components, and this effort would have to be done over. Apart from the loss of time, real confidence in vertical shelter PLU or vertical shelter ABM would have to await the results of this design effort.

OTA estimates that the lifecycle costs for a 4,600 vertical shelter system with a 1989 FOC would be reduced by about \$1.5 billion (fiscal year 1980 dollars) if the shift were made to vertical shelters now.

## 3. Valley Cluster Basing

A variant of the baseline system, that has received serious consideration within DOD during the first part of 1981, is to replace "individual clusters" with "valley clusters." This change would mean creating a single large cluster in each valley, establishing the roads so that it would be possible to move a missile between any two shelters in the same valley. This approach is in contrast to the baseline arrangement in which only 1 missile has access to each group of 23 shelters, and each missile can be placed only in one of its "own" 23 shelters. Valley clustering would not alter the design of the missiles, shelters, or transporter trucks.

This change would have the following effects:

1. It would require fewer maintenance facilities. Instead of 1 facility per cluster of 23 shelters (required because the transporter trucks could not carry missiles from one cluster to another), there could be only one or two facilities per valley. This would save money in both construction and operation.
2. It would require fewer transporter trucks. Instead of one transporter per missile, it would be possible to have one transporter for several missiles. This would save money, but it would mean that reshuffling all the missiles and decoys would take longer, and it would limit the possibility of “dash to shelter” as a fallback mode if PLU were broken.
3. It would have only marginal effects on PLU.
4. It could make arms-control verification more difficult. While it would probably not affect the difficulty of clandestinely introducing additional missiles into the deployment area (i.e., putting missiles in shelters that are supposed to contain decoys), it would make it most difficult to verify after the fact that such cheating had or had not taken place. Since this drawback is the same as the drawback of saving money by eliminating the so-called “SALT ports” (openable hatches in the tops of shelters designed to facilitate verification), valley clusters and elimination of SALT ports (which would save money) appear to some as an attractive combination.
5. Valley clusters would not change the principal regional impacts.

On balance, shifting to valley clusters, if combined with the elimination of SALT ports, might save close to \$2 billion (fiscal year 1980 dollars), at the cost of slower reshuffling and more difficult verification.

#### 4. Split Basing MPS: Nevada/Utah and West Texas/New Mexico

Split basing would locate half of the shelters in the Great Basin of Nevada and Utah, and half in the Southern High Plains of west Texas and New Mexico. The rationale would be to mitigate the adverse regional impacts— both socioeconomic and physical — by making the deployment in each region smaller.

Split basing would mitigate some of the adverse impacts of MPS. The mitigation would arise from the likelihood that the rapid changes created by MX/MPS construction could be below thresholds where they become difficult or impossible to manage in the available time. However, if the baseline shelter number (4,600) and construction rate (roughly 1,200 per year) proved inadequate, then split basing would probably not mitigate the impacts, but might make system expansion easier because plenty of suitable land would be readily available. Split basing could complicate issues of land acquisition, since the land to be used in Nevada and Utah is largely public land, while the land in west Texas and New Mexico is largely in private hands.

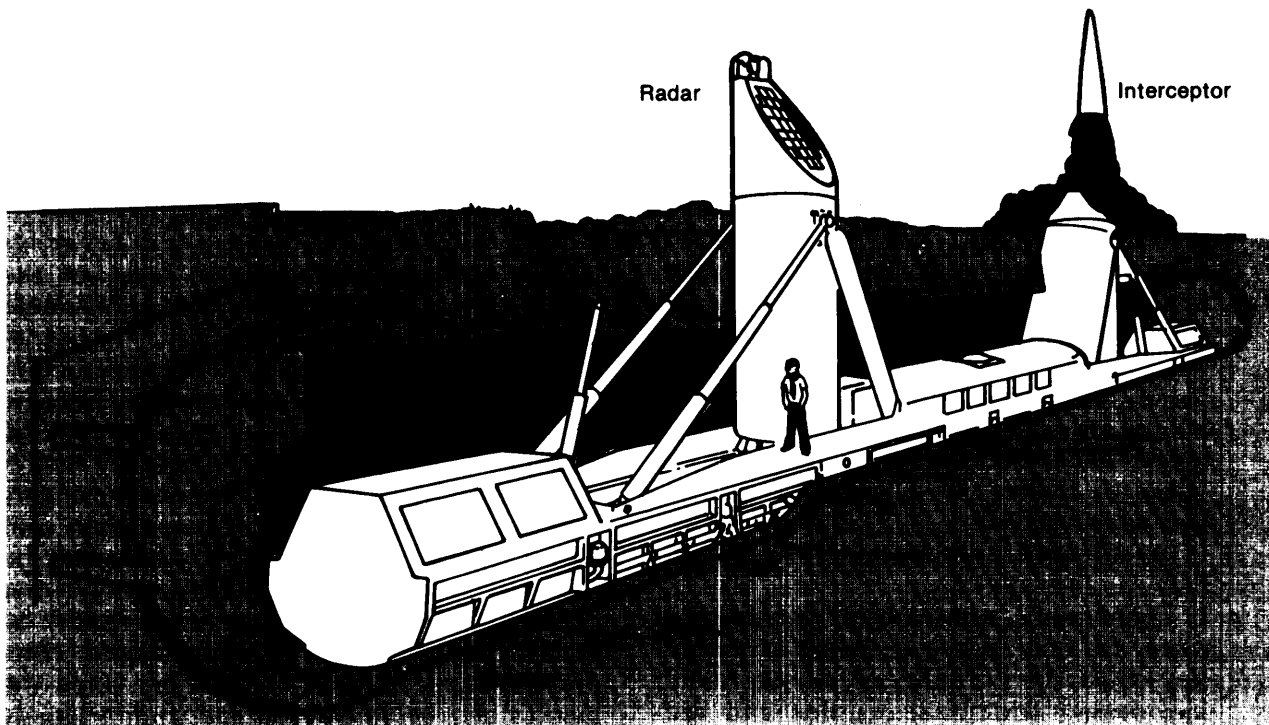
Split basing would increase the costs of both construction and operation by about 7 to 10 percent.

#### 5. MX/MPS With a LoADS ABM System

An alternative to increasing the number of shelters in the face of an expanded Soviet threat would be to provide the MPS system with a ballistic missile defense. The Army’s LoADS has been proposed for the role of defending an MPS system.

The LoADS defense unit (DU) (fig. 5), consisting of a tracking radar and nuclear-armed interceptor missiles, would be designed to fit in the shelters and appear just like an MX missile or a decoy to outside observers or sen-

Figure 5.— LoADS Defense Unit After Breakout  
(human figure indicates scales)



SOURCE. Off Ice of Technology Assessment

sors. A DU would be hidden in each cluster of shelters and programed to defend the shelter containing the MX missile. The DU might also have to defend itself. When it became apparent that a Soviet attack was on the way, the DU would break through the top of the shelter and prepare to fire.

The Soviets would have to target two warheads at the shelter containing the MX missile, since the first one would be intercepted by LoADS with high probability. Since the Soviets would not know which shelter contained the MX, they would have to target two RVS against each of the shelters in the cluster. Thus, addition of LoADS to the baseline MPS system would double the price the attacker would have to pay to destroy an MX missile from 23 to 46 RVS. The effect would be the same as doubling the number of shelters while keeping the number of missiles the same.

It is possible to have high confidence that LoADS would exact a price of 2 RVS per shelter

if the locations of LoADS DUS and the MX missiles could be concealed and if the DU could be hardened to survive the effects of nearby nuclear detonations. This confidence, conditional upon successful deception and nuclear hardness, results both from advances in ballistic missile defense (BMD) technology in the last decade and from the relatively modest goal of exacting from the Soviets one more RV per shelter.

Successful deception would be essential for LoADS defense, since if the Soviets found out which shelter contained the DU, they could attack that shelter first, force the DU to use up all its interceptors in self-defense, and then attack the remaining shelters using one RV per shelter. The situation would be far worse if detection of the DU somehow made it feasible for the Soviets to locate the MX missile as well. Since the DU would be a functional object—not just a decoy that could be designed in any way that would make it indistinguishable from

a missile to Soviet sensors— PLU would become considerably more complex if LoADS were added to MX/MPS. It would probably be necessary to alter some features of the MX missile canisters and the decoys to mimic distinctive features of the LoADS DU. Because of this possibility, a deferred decision to deploy LoADS (made after the dimensions of the future Soviet threat became clearer) would entail more risk and cost unless the MPS system had been designed with the LoADS addition in mind.

The LoADS DU would have to survive and operate in a nuclear effects environment unprecedented for so complex a piece of equipment. Measures taken to protect the DU would furthermore have to be consistent with the severe design constraints imposed by PLU. It is not possible to have confidence that the goals of PLU and nuclear hardening can be met — separately, much less simultaneously— until detailed design and testing are done.

There is a variety of ways in which the Soviets might respond to deployment of LoADS, involving both special attack strategies and new weapon systems, which could pose a threat to the defense's effectiveness. These so-called "reactive threats" are discussed in chapter 3 of this report and its classified annex. The risks to LoADS' effectiveness (in forcing the Soviets to target each shelter twice) from these threats appear to be moderate.

Because LoADS would be integrated into the MPS system, the environmental impacts would be essentially the same as for baseline MX/MPS.

LoADS DUS that were mobile or that contained more than one interceptor missile per DU could not be developed outside of the laboratory, tested, or deployed within the terms of the ABM Limitation Treaty reached at SALT 1. Pursuing this option from the present technology development stage into prototyping or deployment would require amendment or abrogation of the Treaty. The diplomatic and political consequences of seeking amendment or unilaterally withdrawing from the

Treaty are beyond the scope of this study. Amendment or abrogation would give the Soviets the legal right to develop and deploy an ABM system of their own. A Soviet ABM deployment might create a situation in which the United States felt it needed more surviving MX missiles, and hence a larger deployment, to be sure of destroying defended Soviet targets.

## 6. MPS Deployment of Minuteman III

A related possibility would be to construct additional silos or shelters in the existing Minuteman III fields, and modify the Minuteman III missiles to permit them to be moved around deceptively and concealed among the available shelters. The rationale for such an option would be to use the MPS concept to make the existing Minuteman III missile survivable, thereby saving time and money. Such a system might replace MX altogether, or it might serve as a precursor system, with MX gradually replacing Minuteman III missiles in the new MPS field. It could also serve as an interim measure, providing survivable land basing until some other mode of MX basing was ready.

Such a system appears to be technically feasible. The existing Minuteman III missiles and launch-support equipment would be canisterized separately to facilitate movement among protective shelters. New transporters for the Minuteman missiles and associated equipment would have to be procured, and roads in the deployment area would have to be upgraded. It would also be necessary to design a system for maintaining Minuteman PLU similar to but not identical to the system of maintaining PLU for the MX. Minuteman PLU would have similar technical risks and uncertainties, although the institutional problems would be altered by the predominance of private lands. The regional impacts would be similarly altered, and OTA'S analysis suggests that both the range of likely impacts and the probability of extremely severe impacts would be reduced. It would be possible, at additional cost, to replace the existing guidance system with the new AIRS (advanced inertial reference sphere)

guidance system being designed for MX; this would upgrade the military capability of Minuteman III to the level of the MX missile, except that since each missile would carry fewer warheads, more missiles would be required for an equivalent capability.

Cost and schedule are of particular interest in considering an MPS rebasing of Minuteman III, since this basing mode was originally proposed as a "quick fix." Assuming a firm decision in July 1981, it appears that Minuteman MPS could not be deployed on a faster schedule than MX/MPS. Because of the need to replicate for Minuteman the design work already done on PLU for MX, and the need to begin the environmental impact statement and land acquisition processes, construction for Minuteman rebasing probably could not begin before the spring of 1985, and FOC for a survivable 5,800-shelter Minuteman MPS system would probably be in the spring of 1989. Cost of a Minuteman MPS would be less than the cost of MX/MPS. OTA estimates that Minuteman MPS system composed of 5,800 shelters and 667 missiles, which would have roughly equivalent survivability to baseline MX/MPS and existing silo-based Minuteman, could be built and operated for about \$36 billion, or roughly \$7 billion less than MX/MPS (fiscal year 1980 dollars). This figure would include reopening the Minuteman production line to provide test missiles and spares, but would not include the cost of retrofitting the MX guidance system (AIRS) on to the Minuteman III missiles. If the systems had to be augmented (whether by expansion, by adding LoADS, or both) to meet an expanded Soviet threat, the cost advantage of Minuteman III MPS would diminish somewhat.

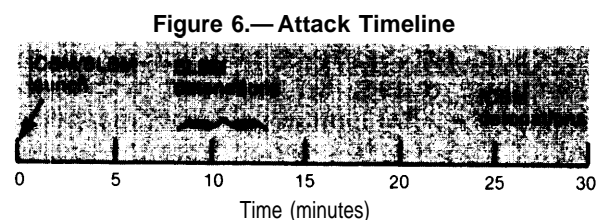
Expanding a Minuteman MPS system to maintain survivability against an expanded threat would require a substantial increase in the total number of U.S. multiple independently targeted reentry vehicle ICBMS. This would run counter to the approach to offensive arms control which both the United States and the Soviets have espoused during the last decade of SALT negotiations.

## 7. Launch Under Attack

Another approach to MX survivability (or, for that matter, Minuteman survivability) is to base the missiles in fixed silos, accept the vulnerability of these silos, and resolve to launch the missiles before Soviet RVS could arrive to destroy them (fig. 6 gives the attack timeline of LUA.). Such a posture is known as launch under attack (LUA). Adopting this approach to basing MX would mean choosing to rely on LUA.

To have high confidence in the technical aspects of LUA, the United States would have to begin by substantially upgrading the systems that provide warning of an attack and emergency communications. OTA'S analysis indicates that providing sensors and communications links that were highly reliable in the face of Soviet efforts to destroy or disrupt them is feasible but would require time, money, and continued effort. Almost all improvements in this area could be deployed by the end of the decade at a cost of several billion dollars. The total cost of this basing mode, including the MX missiles, might be about half that of baseline MPS. Some of the systems required for LUA would be desirable, or perhaps even necessary, for other basing modes as well.

Once this were done, we could have high confidence that LUA was technically feasible provided that National Command Authorities (i.e., individuals empowered to order the launch of the MX missiles) were in communication with a command post at the moment the Soviet attack was detected so that they could assess its meaning, decide how to respond, and



SOURCE Office of Technology Assessment.



communicate a launch order to the forces in a short period of time. Whether the President would be available at all times for this purpose, or delegate his most awesome authority to someone who was, is clearly not a matter of technology but of decision at the highest level of government.

Apart from this question, LUA has several attractive features as an MX basing mode. Because existing silos could be modified for use by MX missiles, there need not be any major environmental or societal impact. The cost would be lower than for any other MX basing mode, and deployment could take place as soon as MX missiles were produced. LUA would preserve familiar features of silo basing, including weapon effectiveness as measured by accuracy, time-on-target control, retargeting capability, and the like; familiar force management procedures; and familiar arms control verification procedures. The same targets (and perhaps more) would be available in the first few minutes of a war as in the first few hours or days. An LUA force could therefore participate in U.S. war plans in any role except that of a secure reserve force.

Reliance on LUA also has some serious drawbacks. Decision time would be very short. Depending on the circumstances, decision-makers could lack crucial information regarding the extent and intent of the Soviet attack — e.g., information about targets which the Soviets had chosen not to attack. Such information could be necessary to gauge the proper response. Decisionmakers would also lack an interval between attack and response during which an effort could be made to assess intelligence information, consider diplomatic measures, and signal the intent of the U.S. response.

No matter how much money and ingenuity were devoted to designing safeguards for the U.S. capability to launch under attack, and even if these safeguards were very robust indeed, it would never be possible to eradicate a lingering fear that the Soviets might find some way to sidestep them.

Finally, despite all safeguards, there would always remain the possibility of error; depending on the nature of the error, it could mean a successful Soviet first strike against MX or it could mean a nuclear war started by accident.

## 8. Silo-Basing With an ABM Defense

For defending a relatively small number of targets such as MX silos, an ABM system that operates outside the atmosphere is preferable in theory to a low altitude defense system. This is because an exo-atmospheric (or “exo”) defense could intercept many RVS headed for a single silo, whereas after a small number of intercepts an endo-atmospheric (“endo”) system would find further defense precluded by the effects of its own and attacking nuclear weapons. A combination of exo and endo — a so-called layered defense — is an attractive concept because the principal limitation of each layer could be alleviated by the presence of the other: the exo defense would break up the dense and structured attacks which could otherwise overwhelm an endo defense, while an endo defense could cope with the relatively few enemy RVS that would almost certainly “leak” through the exo defense.

The Army’s concept of exo defense, called the “Overlay,” is in the technology exploration stage. No detailed design is available, such as exists for LoADS. In outline, the concept consists of interceptor missiles roughly the size of offensive missiles, equipped with infrared sensors, and carrying several kill vehicles, also equipped with infrared sensors. The interceptors would be launched into space, where the infrared sensors would detect approaching RVS as warm spots against the cold background of space. The kill vehicles would be dispatched to destroy the RVS either by colliding with them directly or by deploying a barrier of material in their path.

Because no specific system based on the Overlay concept has been worked out, it is not possible to analyze in detail the effectiveness of the Overlay in various attack scenarios. It is

clear that high efficiency would be required if it were to be able to defend a small number of MX missiles against a large Soviet attack. There are at present many uncertainties about whether the Overlay could achieve the high performance it would require to satisfy the needs of MX basing. These uncertainties concern both the underlying technology and the defense system as a whole. The technical risk associated with layered defense based on the Overlay is therefore high—substantially higher than the risk associated with LoADS.

In addition to uncertainties and consequent risk associated with the Overlay, there is a potential “Achilles’ heel” in the vulnerability of infrared sensing to decoys and other penetration aids. Unlike the LoADS radar, which could measure the weight of approaching objects after they entered the atmosphere, the Overlay’s infrared sensors would measure their temperature characteristics. Lightweight decoys could be made which resembled in their temperature characteristics the heavier RVS.

The Overlay is not a system that is developed and ready for the role of defending silo-based MX. As the concept matures, it will have to deal with the fundamental problem of decoy discrimination as well as with the design of a specific working system. For the moment, it would be quite risky to rely on the Overlay, or on layered defense, as the basis for MX basing.

As in the case of LoADS, development or deployment of an Overlay or layered defense would require amendment or abrogation of the ABM Treaty reached at SALT 1.

### 9. Basing on Small Submarines

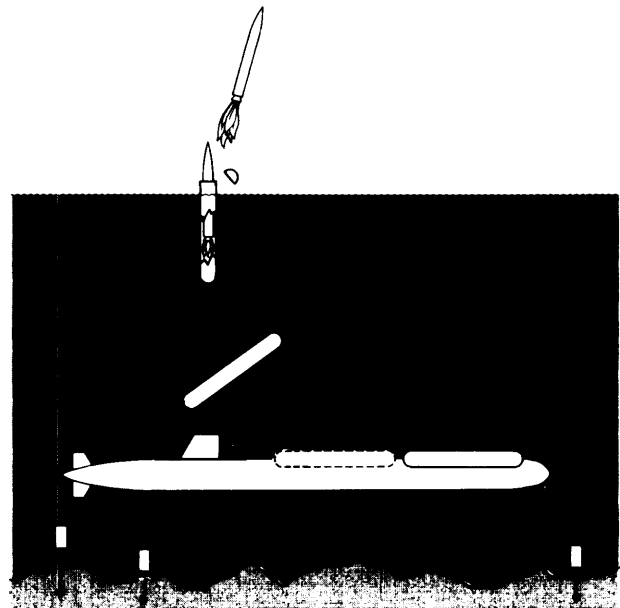
It would be technically feasible to build, deploy, and logistically support a fleet of small MX-carrying diesel-electric-powered submarines. These submarines could operate within 1,000 to 1,500 nautical miles of three bases, located on the east and west coasts of the continental United States and on the coast of Alaska. These submarines would be highly survivable against all existing antisubmarine threats, and against all future antisubmarine warfare technologies which OTA was able to

project. An alternative means of propulsion, using inexpensive low-powered nuclear reactors, is also possible.

At present, no detailed design exists for a submarine force specifically optimized to have flexibility, responsiveness, and accuracy comparable to that of the ICBM leg of the Triad. In order to provide a basis for analyzing the degree to which these attributes could be achieved in a submarine-based MX, OTA has postulated a system optimized for this purpose. The system postulated uses proven technologies and existing U.S. Navy operational practices wherever possible, and therefore differs; in some respects from the “SUM” concept developed by Sidney Drell and Richard Garwin.

The system assessed by OTA would consist of 51 moderate-sized diesel-electric submarines, each of which carries 4 MX missiles (fig. 7). The missiles in their capsules would be carried horizontally outside the pressure hull. During normal operations about 28 submarines would be at sea at all times, while the remainder would be in port for refits or over-

**Figure 7.—Conceptual Submarine-Launch MX Missiles**



SOURCE: Office of Technology Assessment

hauls, The submarines would have pressure hull displacements comparable to those of existing U.S. and Allied diesel-electric submarines. If an operational need arose, the submarines would have sufficient size, speed, and endurance to operate at distances in excess of the proposed 1,000 to 1,500 nautical miles from bases.

Small submarine basing raises two quite different kinds of issues. The first class of issues relates to whether or not small submarine basing is appropriate for MX; the second class of issues are technical questions about the extent to which such a basing mode would enable X to meet the requirements for which it is being designed.

Placing the MX missile on board submarines would mean that well over half of the U.S. strategic force of the 1990's would be submarine-based. This would obviously exacerbate the problems that would develop if—contrary to expectations—the Soviets were to develop an antisubmarine warfare capability that was effective against ballistic missile submarines. It would not be possible to build a new fleet of submarines without an expansion of U.S. submarine shipbuilding capacity. It would be necessary for three shipyards that do not now build submarines to learn how to do so. Submarine construction is complex, and involves more exacting quality control than surface ship construction. Delays could occur if the shipyards have difficulties in implementing the necessary quality control and construction techniques, or if the industrial base supplying certain critical materials is not expanded fast enough. Problems could be encountered in recruiting and retaining enough skilled and dedicated personnel to man such a fleet.

There is no particular reason why the existing Minuteman force would have to be taken out of service as soon as MX was deployed on submarines, and so the land-based ICBM leg of U.S. strategic forces would continue to exist. (Existing plans for, and OTA analyses of, other basing modes assume the

continued operation of Minuteman after MX deploy merit.) However, its relative weight would be diminished, and this could have political significance. There is a school of thought which holds that basing a major portion of U.S. strategic forces on U.S. soil (so-called “sovereign basing”) makes a significant contribution to deterrence. Moreover, changing the relative weight of land- and sea-based forces would create institutional problems for both the Air Force and Navy.

On the other hand, submarine basing of MX could lend an element of stability to the arms race, since a Soviet counter would involve increasing their already high level of effort in the apparently unpromising area of strategic anti-submarine warfare rather than increasing the number of their nuclear weapons. Submarine basing would be fully compatible with existing arms control concepts and verification procedures. The technical risks would be low.

OTA'S analysis focused on those aspects of submarine basing where it is possible to make comparisons with other basing modes: survivability, accuracy, responsiveness (including the effectiveness of command, control, and communications), environmental impact, cost, and schedule.

Chapter 5 contains an extensive discussion of the issue of submarine survivability. In brief, OTA could find no existing technology, and no technology believed to be on the horizon, which offers any promise for permitting an effective Soviet attack on a fleet of small MX-carrying submarines. However, the possibility that the Soviets may discover and deploy some antisubmarine warfare technology which cannot be foreseen cannot be excluded. If this were to happen, the differences between the Trident fleet (a small number of high-speed boats operating in an enormous deployment area) and the MX fleet (a large number of slower boats operating relatively close to the United States) could make it more difficult, and perhaps impossible, for the Soviets to deploy an antisubmarine warfare force capable of attacking both U.S. ballistic missile submarine forces.

"Endurance" is defined as the ability to survive for weeks and months *assuming* that a system has survived for a few days. The small submarines which OTA envisaged would have to return to a port (or conceivably an at-sea tender) 1 to 4 months after an attack, depending on how long each submarine had already been at sea when the attack took place.

Submarine-based MX missiles could achieve accuracies close or equal to the engineering-design requirements for the land-based MX missile. While it appears likely that land-based MX accuracies would exceed these requirements, submarine-based systems may well have such high damage expectancies against very hard targets that further improvements in accuracy would not have military significance.

OTA could find no reason to believe that the construction of three new submarine bases would have environmental impacts unlike those associated with comparable construction projects in coastal areas. In this case, the impacts would be confined to the immediate areas surrounding the three operating bases, and should be manageable.

Any estimate of the cost of small submarine basing can only be approximate, since no detailed design exists. Acquisition cost of the system described here is estimated to be about \$32 billion (fiscal year 1980 dollars), with another \$7 billion to operate the system until 2000.

Construction of submarines is a complex and specialized task, involving rigorous quality control and specialized materials not normally required for shipbuilding. At present there are only two shipyards in the United States capable of building submarines, and both are backlogged. Bringing additional shipyards to the point where they could build submarines, and obtaining the necessary parts and materials, could perhaps involve substantial delays. OTA estimates that the first such submarine could not be operational before 1988 at the very earliest, with 1990 a more realistic date. Four more years would be needed before the force reached the number of 51. Efforts to accelerate this schedule (or, if things went

wrong, to maintain this schedule) could delay other, existing submarine construction programs. However, the first MX missiles deployed on small submarines would be highly survivable, in contrast to other basing modes which would attain survivability only after most or all of the force was operational.

## 10. Surface Ship Mobile

Another approach to seeking survival by mobility at sea is to base the MX missiles on a fleet of surface ships. Such a fleet would be designed to have an appearance similar to merchant shipping, and to hide itself either in broad expanses of the ocean or among the other ships in crowded shipping lanes. The techniques for lowering missiles over the side of a ship and launching them from the water are well-established, although other launching modes might prove preferable.

Most of the points noted in the previous section about shifting the weight of U.S. strategic forces from land to sea apply. Unlike submarines, the surface ships would have a security problem in making certain that third parties did not attempt to seize the MX missiles. The ships would have to have a considerable capability for self-defense. The need for defensive weaponry could make it more difficult to disguise the ships.

An examination of the way in which such a force of surface ships might operate reveals numerous operational problems, which interact with the task of assuring survivability. Briefly, the Soviets could destroy any MX-carrying surface ship which they could locate or, having located, trail. OTA'S analysis (ch. 7) assumes that by the 1990's the Soviets would deploy a large force whose purpose was to locate and trail such ships, and finds that in such a case the proportion of a fleet of such ships which would be located and under trail might fluctuate greatly from day to day. Hence, although attacking such ships would be a formidable task for the Soviets, the United States could not have confidence in the survivability of surface-ship mobile MX.

While cost and schedule estimates cannot be precise for a system that has never been designed in detail, it is estimated that surface-ship acquisition costs would be comparable to those of a fleet of small submarines. Annual operating costs would be slightly higher than those of small submarines. These differences are within the range of expected error. A surface ship fleet might be operational a year or two before a submarine fleet. Given the greater survivability of submarine basing, it would seem to be preferable to surface ship basing if sea mobile basing is chosen.

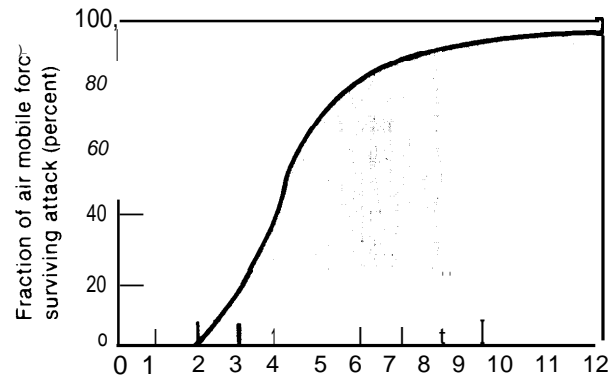
### 11. Air Mobile

Air mobile MX would be a system of great operational complexity, and therefore there is a corresponding wide choice of specific concepts. The lowest cost concept would consist of 75 or so wide-bodied aircraft, each carrying two MX missiles, maintained on strip alert at airfields located in the Central United States.

Such a “dash-on-warning” air mobile force could be highly survivable. The principal threat to the force would be submarine-launched ballistic missiles (SLBMs) launched from positions near U.S. coasts. Such an attack could arrive in the vicinity of the alert airfields within 15 minutes of launch and seek to destroy the aircraft before they could take off and escape. However, if a high-alert posture were accepted for the force, meaning that the aircraft took off *immediately upon timely warning* of SLBM attack, almost the whole force would survive even if a large number of SLBMs were launched from positions near U.S. coasts (see fig 8). The Soviet SLBM force is presently incapable of such an attack. Air-mobile basing could therefore stress Soviet strategic forces where they would be least able to respond in the short term.

Nevertheless, the difference between survival and destruction of the force would be a very few minutes, depending on timely tactical warning. In this respect an air mobile ICBM force would replicate a significant failure mode of another leg of the strategic Triad — the bomber force.

**Figure 8.—Survivability v. Escape Time  
(8 EMT on Each Airstrip, 2 PSI Aircraft)**



Aircraft escape time before arrival of SLBM attack (minutes)

SOURCE: Office of Technology Assessment

ICBMs, arriving later than the SLBMs, could not threaten the survivability of the force as a whole, since by that time the aircraft would have been in flight long enough to be dispersed over a wide area. Effective barrage attack of this area would require the Soviets to build many more large ICBM *missiles* than they now possess and use them to barrage a million or so square miles. The outcome of such an attack would be insensitive to both the fractionation (the apportioning of the missile payload among a small number of large-yield [ge-yield RVS or a larger number of smaller yield RVS) and to the accuracy of Soviet ICBM forces.

The principal disadvantage of a dash-on-warning force—the need for reliable, timely warning—could in principle be removed by having the aircraft maintain continuous airborne patrol. However, even with a new aircraft designed for low fuel consumption, the cost of operating such a force would be prohibitive. A continuously airborne force of 75 aircraft (150 MX missiles) could cost \$80 billion to \$100 billion (fiscal year 1980 dollars) to acquire and to operate for 10 years after full deployment (FOC).

A second crucial problem for an air mobile force concerns the question of postattack endurance. After a few hours of flight, the aircraft would have to land and refuel. Since their home airfields would be destroyed, they would

have to find other places to land and await further instructions. This problem could be avoided completely if the United States were willing to adopt a policy of "use it or lose it" for the few hours of unrefueled flight. There are also several hundred civilian and military airfields in the United States capable of servicing large aircraft. Many of these airfields are located close to urban areas. If the Soviets wished to deny postattack endurance to an air mobile fleet—tantamount to forcing the United States to "use it or lose it"—they would have to attack these airfields. A serious effort to build more austere recovery airstrips throughout the country than the Soviets possessed ICBM RVS to destroy them would be enormously expensive, would have substantial environmental impact, and would be completely impractical if the Soviet threat grew large. For instance, 4,600 airfields spaced 25 miles apart would fill the entire 3 million square miles of the continental United States.

There could conceivably be some value in having more airfields suitable for air mobile operations than the Soviets had SLBM RVS. These could be useful if the United States doubted the reliability of its SLBM warning sensors and wished to relax the force's alert posture (since, in a crisis, false-alarm takeoff might be mistake—by the Soviets for preparation to launch the MX missiles), or if the fleet were somehow "spoofed" into taking off (thus making a portion vulnerable as the aircraft were forced to land). A force with this dispersal option could cost \$10 billion to \$20 billion (fiscal year 1980 dollars) more than a wide-bodied jet force with no recovery airfields beyond existing large civilian and military airfields.

Thus, the lowest cost air mobile system would exclude extra recovery airfields beyond those large civilian and military airfields which exist at present. Although OTA has not performed detailed cost and schedule analysis for such an air mobile option, it appears that the cost of a force with 75 aircraft (150 MX missiles) on alert would be comparable to the cost of the baseline MPS system and could be deployed in a comparable time.

An air mobile force would also require several supporting systems. First and foremost would be reliable sensor systems for timely warning of Soviet attack. Providing such systems would be technically feasible but would require time, money, and continued effort. The complex force management needs of the air mobile force after attack would require a comparably complex communications system. Last, providing for missile accuracy comparable to land basing would require use of the Global Positioning Satellite system or a Ground Beacon System.

## COMPARISON OF BASING MODES

As we have indicated above, OTA'S technical analysis of MX basing modes does not support a clear or simple choice. All of the basing modes reviewed have strengths and weaknesses. This section presents the criteria OTA has identified for the purpose of analysis, and uses them to compare the five most feasible options. Since no basing mode ranks high against all criteria, choosing among them depends on the relative weight attached to each.

### Technical Risk

Technical risk refers to the level of confidence that one can have *at this time* that the system will perform the way it is supposed to.

There are significant risks associated with two of the five basing modes considered. PLU will represent an area of significant technical risk for MPS basing until prototypes have been tested, and could be a subject of lingering doubts even afterwards. The use of LoADS with MPS would compound this risk. An additional technical risk for LoADS concerns the requirement that LoADS operate in a nuclear environment of unprecedented severity, inducting high-yield nuclear donations roughly a mile away.

The risks of LUA arise not from technically difficult problems, but from the uncertainties of the interface between men and machines.

## Survivability

A force is "survivable" if its destruction by a Soviet first strike is infeasible. Some basing modes aim at protecting the entire force while others accept some attrition and size the system to assure an adequate number of survivors. Survivability would be of critical importance to deterrence in either of two scenarios. The first is that the Soviets considered an all-out war inevitable, and were considering whether striking first would limit the damage such a war would cause to the Soviet Union. The second is that the Soviets sought to control the outcome of a crisis by partially disarming the United States while deterring the United States from responding. In either case, it would be important that the United States could feel confident that the Soviets would doubt their ability to destroy a relatively large proportion of U.S. strategic forces. All the MX basing modes are designed to provide this assurance, but they do so in different ways. For this reason, they create somewhat different risks.

A timely decision to launch under attack would prevent the Soviets from destroying the missiles before they were used. Air mobile MX would become vulnerable if the United States failed to receive and act on adequate warning, a failure mode which it would share with the bomber leg of the Triad. The MPS systems (including the MPS/LoADS combination) would become vulnerable if PLU broke down, and would also become vulnerable whenever the size of the MPS system was too small relative to the Soviet threat. This latter occurrence is not so much a question of technology as it is a question of the judgment and optimism of U.S. policy makers: a rapid growth in the Soviet threat could make MPS vulnerable unless the United States had decided to expand the system *before* Soviet intentions had become clear. Small submarines do not appear to be vulnerable, either now or in the foreseeable future. However, if an unforeseen Soviet breakthrough in antisubmarine warfare occurred, it is possible that it would threaten both small submarines and the Trident/Poseidon leg of the Triad.

LUA would become progressively less vulnerable as improved warning and communications systems were brought online. MPS (with or without LoADS) would become survivable only after the number of shelters deployed surpassed the number of Soviet RVS available to attack them. Small submarines would be highly survivable when first deployed.

## Endurance

Endurance is defined as the capability to survive as an integrated system — both missiles and the communications needed to use them — for an extended period after a nuclear attack, *assuming* that the system survives the attack itself. An LUA system would clearly have no endurance.

An air mobile system would not endure longer than 5 to 8 hours unless the Soviets chose not to attack the airfields at which the MX-carrying aircraft could land and refuel. LoADS could be ineffective against a second attack. Small submarines with diesel-electric propulsion would endure from 1 to 4 months at sea, and longer if provisions were made for replenishment. Nuclear-electric propulsion could provide longer endurance for small submarines. MX, MPS is designed to endure in a low-power mode for many months after an attack.

## Weapon Effectiveness

This criterion addresses the question of how well MX in the various basing modes could support those aspects of U.S. nuclear weapons employment policy which have previously been the specialty of the ICBM leg of the Triad, including ability to destroy hardened Soviet targets (accuracy and time-on-target control), strike rapidly on command (responsiveness), and support a doctrine of flexible response (retargeting capability).

Land-based systems (MPS, MPS with LoADS, and LUA) will continue to set the standard for accuracy, time-on-target control, responsiveness, and rapid retargeting. MX based on small submarines would be almost as good, and in-

deed would most probably be close to or equal the design requirements for MX. There would be few if any military missions of importance for which a submarine-based MX (given feasible upgrades in guidance systems, navigational aids, and C<sup>3</sup> systems) would be significantly less capable than land-based MX. Air mobile basing would sacrifice a degree of responsiveness because of the need for the aircraft to takeoff before launching the missiles, would require external navigation aids to achieve high accuracy, and management of a dispersed air mobile force could be very complex.

### Command, Control, and Communications (C<sup>3</sup>)

Reliable communications impervious to Soviet attempts at disruption are needed for commanders to assess the status of the MX force, retarget the missiles if desired, and transmit launch commands. The technical means to accomplish these tasks, as well as the tasks themselves, could be very different in the preattack, transattack, and postattack periods.

There are distinct and important differences from basing mode to basing mode regarding both the technical means to support effective C<sup>3</sup> and potential vulnerabilities. In each case, it appears that with adequate funding and effort, acceptable technical solutions are available, though it would be extremely difficult to secure any C<sup>3</sup> system against any and all contingencies. On balance, OTA has found no clear technical reason for preference among the basing modes on the basis of C<sup>3</sup>.

### Arms Control Considerations

The choice of basing mode could affect arms control in several ways. First there is the question of whether a given basing mode conflicts with U.S. obligations under a treaty now in force. Also of interest are possible conflicts with treaties signed but not ratified. Apart from specific treaty provisions, the United States has a longstanding policy that strategic systems should be amenable to verification. The impacts of MX basing on future arms control negotiation are speculative. They involve

not only the negotiability of future arms control agreements, but also incentives which might be created for increasing or reducing the level of strategic armaments.

Deployment of a LoADS ABM system in defense of MPS would require amendment of, or U.S. withdrawal from, the ABM Treaty reached at SALT 1, though much predeployment work could be done within the terms of the Treaty. In general, the five basing modes we are comparing appear compatible with the provisions of SALT 11. MX/MPS has been designed specifically to be compatible with this proposed Treaty.

A future arms control agreement that permitted MPS basing but limited the number of missiles could be verified if the system were designed from the outset with this in mind. An agreement permitting the deployment of the MX missile on small submarines or aircraft could be verified using established procedures and national technical means.

MPS basing could complicate future arms control negotiations. Detailed understandings about deployment procedures and peacetime operations, not previously included in arms control agreements, could be required for the United States to verify limits on a Soviet MPS deployment. Because MPS deployments must be large in order to be survivable, MPS basing could tend to provide incentives for continuing increases in numbers of strategic arms, and complicate efforts to seek agreements limiting or reducing these numbers. Moreover, MPS would necessarily focus attention on numbers of RVS.

### Institutional Constraints

The Navy has shown little interest in small submarine basing of MX, and the Air Force opposes it. The LoADS ABM concept would not challenge existing roles and missions, but it would require early and close Army/Air Force cooperation, MX/MPS would strain the ability of Federal, State, and local jurisdictions to plan and coordinate adequate provision of social services and environmental protection.



### Impacts on the Physical Environment

MPS systems would have considerably greater physical impacts than the other basing modes considered. In the Great Basin of Nevada and Utah these impacts would be particularly severe and could include the long-term loss of thousands of square miles of productive rangelands. Although the qualitative impacts of both split basing and Minuteman MPS would be essentially the same, the magnitude of these impacts would be significantly reduced by split basing and could be reduced further by basing in the northern Minuteman fields. Impacts of air mobile basing would result from airfield construction, but severe impacts would be unlikely. The impacts of submarine basing would be site-specific and confined to the areas where operating bases would be built, but could be significant within these areas. The impacts of LUA as a basing mode would be minimal.

### Socioeconomic Impacts

The magnitude of MPS construction would have major impacts on the socioeconomic structure of any deployment area selected on the basis of minimum population criteria. Furthermore, uncertainties regarding the size and the distribution of the work force population would make advance planning so difficult that effective mitigation of adverse impacts would

be unlikely. These impacts would be most severe in the case of MPS in Nevada and Utah, but would also accompany split basing or rebasing of Minuteman III.

The impacts of air mobile and submarine basing would be confined to the areas where operating bases were built, and might be positive or negative depending on the characteristics of the areas chosen. LUA would have no impact.

### costs

OTA has compared costs on the basis of "lifecycle" cost, which includes both the cost of acquiring the system and the cost of operating it until 2000.

The baseline MX MPS system of 200" missiles and 4,600 shelters was sized to provide adequate survivability against a particular Soviet threat. For costing purposes, OTA has sized the other systems to provide equivalent survivability against a comparable threat. If the Soviet threat should grow, MPS systems (including MX defended by Lo ADS and Minuteman, MPS) would have to grow accordingly. Submarine basing, air mobile basing, and reliance on LUA would not.

Table 1 summarizes OI's cost estimates for the basing systems. The lifecycle cost of baseline MPS (4,600 shelters with 200" missiles),

**Table 1.—Summary, Lifecycle Cost Estimates for Basing Options**  
(billions of fiscal year 1980 dollars)

	MX/MPS baseline	MX/MPS expanded 1990 threat	MX/MPS expanded 1995 threat	MX/MPS vertical shelters	MXIMPS split basing	Small submarine	MM III MPS	MM III expanded 1990 threat	MM III expanded 1995 threat
Number of shelters	4,600	8,250	12,500	4,600	4,600	51*	5,800	10,400	15,500
IOC/ FOC (calendar year) <sup>1</sup>	87/89	87/89	87/94	87/89	87/89	89/95	87/90	87/91	87/94
Number of deployed missiles	200	359	544	200	200	204	667	900	1,100
Development Investment	\$ 9172 27999	\$ 9,372 43,557	\$ 9,572 61,512	\$ 9,172 26,500	\$ 9,172 30,109	\$ 7,225 24,862	\$ 2,527 28,037	\$ 2,500 43,200	\$ 2,500 60,400
Total acquisition ...	\$37,171	\$52,929	\$71,084	\$35,672	\$39,281	\$32,087	\$30,564	\$45,700	\$62,900
Operating and support to year 2000	\$ 6,308	\$ 9,482	\$11,486	\$ 6,308	\$ 6,526	\$ 7,160	\$ 5,907	\$ 7,700	\$ 9,500
Lifecycle cost to 2000	\$43,479	\$62,411	\$82,570	\$41,980	\$45,807	\$39,247	\$36,471	\$53,400	\$72,400

<sup>1</sup>Submarines

small submarines, and air mobile are all about \$40 billion (fiscal year 1980 dollars) OTA estimates that split basing would cost about 7 percent more. Rebasing Minuteman III would be about \$7 billion less expensive than the baseline MX/MPS systems. LUA would be considerably less expensive than the others, even after very substantial upgrading of warning and communications systems.

Against an increased Soviet threat, the cost of MPS would grow. If the Soviets devoted substantial effort to threaten MPS, and if the U.S. response was to increase the number of shelters and missiles, then the lifecycle cost to the year 2000 of \$43 billion for the baseline system (OTA estimate in fiscal year 1980 dollars) might have to grow to \$58 billion to \$62 billion by 1990 and to \$78 billion to \$83 billion by 1995. Adding LoADS instead of increasing the number of shelters could cut costs: a Congressional Budget Office study estimates that using an optimal mix of LoADS, additional shelters, and additional missiles would save about 10 percent against the 1990 threat and about 18 percent against the 1995 threat.

Note that efforts to make the survivability of air mobile independent of warning by means of airborne alert, or to give air mobile some endurance by building additional dispersal airfields, would drive its cost up very sharply.

### Schedule

The advocates of each of these basing modes project initial operating capabilities in the mid- to late 1980's. These projections are based on rather optimistic assumptions, and the record of U.S. development of weapon systems in the recent past suggests that schedule slippages are likely.

In considering schedule it is necessary to distinguish among three dates for each possible basing mode.

1. Initial operating capability (IOC) refers to the date at which the first missiles would enter the active strategic force. This date is

significant from the viewpoint of the overall strategic balance, and concern with how perceptions of this balance may affect U.S. diplomacy.

2. Full operating capability (FOC) refers to the date when the last missiles and basing facilities would become active.
3. Survivability refers to the date when the deployed system is judged to be adequately survivable against the then-existing Soviet threat. This date is significant from the viewpoint of reversing the effects of the growing Soviet capability to destroy the Minuteman force in a first strike.

Depending on the basing mode and the growth in the Soviet threat, survivability could coincide with IOC, could coincide with FOC, or could come at a date between them.

Because considerable engineering development has been accomplished for MX/MPS, it could probably achieve IOC in 1987. Minuteman MPS could not have an IOC before 1986, even though the missiles already exist, because of the need for an environmental impact statement, site selection, land acquisition, and the need to design a PLU system before starting construction. FOC dates for MPS systems would depend on the size of the Soviet threat. Reasonable FOC dates are 1989 or 1990 if 200 missiles and 4,600 shelters prove to be enough, and a Minuteman MPS of comparable size could be completed at about the same time. So long as the threat kept growing, the system could never be completed in the sense that construction could stop. However, survivability could be achieved before Soviet threat growth and U.S. construction stopped. For example, a 1990 threat of 7,000 Soviet RVS could be met by an MX/MPS system of some 8,250 shelters and 360 missiles. These could be completed by 1990 *provided* that a firm decision to build at that rate were made in late 1982 or early 1983—before firm evidence of Soviet building plans is likely to be available. To retain survivability after 1990 would require a building program that kept pace with any continuing growth in the Soviet threat.

LUA could begin, in principle, as soon as MX missiles could be deployed, but upgraded warning and communication systems might not be developed until the end of the decade.

Adding LoADS to MPS would probably not affect FOC significantly. Submarine-based MX IOC could be as early as 1988, but 1990 seems more likely. An FOC for submarines appears achievable as early as 1992, but OTA believes that 1994 would be more realistic. However, since submarine basing would achieve survivability at the IOC date rather than the FOC date, submarine basing might well achieve survivability sooner than any of the other basing modes despite the fact that its IOC could well be the latest.

While OTA has not performed schedule analyses for air mobile, it appears that an air mobile system might also be deployed by the end of the decade.

### Stability

MX basing could affect stability in three different senses. In the first, survivability (which is treated separately above) enhances stability by avoiding a situation in which the Soviets might start a war because they expected to obtain an advantage by destroying vulnerable U.S. forces. Second, MX basing should, if possible, minimize the risks that a war might start because of accident or miscalculation during a crisis. Finally, MX basing could affect the incentives which shape future nuclear weapon deployment decisions: this is called arms race stability.

MPS basing introduces the prospect of an increasing number of U.S. shelters and missiles in response to an increasing number of Soviet RVS. From the U.S. point of view, keeping pace with a growing Soviet threat could be costly

and would put a premium on determining and projecting the number of Soviet RVS. For their part, the Soviets would be tempted to expand their RV inventory, taking advantage of their existing throwweight to overwhelm the U.S. MPS deployment. On the other hand, the Soviets would be concerned about the effects of a growing MX deployment on the survivability of their own ICBMS.

LoADS ABM deployment could permit an MPS deployment to attain survivability against a given threat level with a smaller number of MX missiles; in this sense it would contribute to arms race stability. On the other hand, it could reopen the qualitative arms race in ABM technologies and offensive penetration techniques (including larger numbers of offensive weapons) which the 1972 ABM Limitation Treaty sought to foreclose.

Small submarine basing would be survivable and might force the Soviets to redirect their efforts from building offensive weapons to intensify antisubmarine warfare research. Since strategic antisubmarine warfare appears very unpromising, this would be stabilizing. However, if the Soviets did achieve an antisubmarine warfare "breakthrough," it would be highly destabilizing.

LUA poses the risk of failure during peacetime or during crisis which could lead to accidental war. U.S. deployment of a new missile in a nonsurvivable basing mode could also create a Soviet perception that in a crisis the United States might choose to strike first rather than wait to launch under attack.

Air mobile would be survivable and would therefore not create incentives for the Soviets to expand their ICBM force. However, its dependence on timely warning could create tension in a crisis.

## Chapter 2

# MULTIPLE PROTECTIVE SHELTERS

## Chapter 2.— MULTIPLE PROTECTIVE SHELTERS

	<i>Page</i>		<i>Page</i>
Overview	33	Some Previous MX/MPS Basing Modes.	97
Theory of Multiple Protective Shelters,	34	The Road able Transporter-Erector-	
Preservation of Location Uncertainty,	35	Launcher . . . . .	97
Sizing the MPS System	40	The Trench . . . . .	99
Weapon Characteristics for MPS ..	44	Minuteman MPS and Northern Plains	
The Air Force Baseline	45	Basing .. . . .	101
System Description.	45	Missile Modifications	101
SALT Monitoring Operations	58	Cost and Schedule ..	102
Siting Criteria	59	Civilian Fatalities From a Counterforce	
Roads	61	MPS Strike ..	103
Physical Security System	61		
Land Use Requirements	64		
Water Availability	67		
Physical Impacts.	68		
Socioeconomic Impacts	73		
Regional Energy Development . .	81		
System Schedule.	82		
System Cost	84		
Cost and Schedule of Expanding the			
MX/MPS .. . . .	86		
Split Basing	89		
Vertical Shelters	92		
Shelter Hardness.	92		
Missile Mobility	93		
PLU . . . . .	94		
costs. . . . .	94		
Arms Control. ..	96		

LIST OF TABLES	
<i>Table No</i>	<i>Page</i>
2. Physic Signatures of Missile	36
3. MPS Example . . . . .	42
4. Monitoring Timeline	59
5. Principal Exclusion/Avoidance Criteria	
Used During Screening.	59
6. Candidate Areas . . . . .	61
7. Water Required for MX . . . . .	68
8. Water Uses. . . . .	68
9. Cost Overruns in Large-Scale Projects	77
10. Estimated and Actual Construction	
Work Forces for Coal-Fired	
Power plants . . . . .	78
11. System Time Schedule	83

<i>Table No.</i>	<i>Page</i>
12. Air Force Baseline Estimate 4,600 Shelters . . . . .	84
13. Comparison of Air Force and OTA Cost Estimates . . . . .	86
14. Land Use Requirements . . . . .	87
15. Full-Scale Operations. . . . .	88
16. Lifecycle Cost of 4,600, 8,250, and 12,500 Shelters to the Year 2005 . . . . .	88
17. Air Force Estimates of Additional Split Basing Costs. . . . .	90
18. Lifecycle Costs for Horizontal and Vertical Shelters Deployed in Nevada-Utah . . . . .	97
19. Minuteman MPS Costs. . . . .	102

<i>Figure No.</i>	<i>Page</i>
37. Construction Work Force, Operating Personnel, and Secondary Populations. . . . .	75
38. Baseline Work Force Estimates . . . . .	76
39. Comparison of Onsite and Total Construction Work Force. . . . .	77
40. Construction Work Force: High-Range Projection . . . . .	78
41. Range of Secondary Population Growth. . . . .	79
42. Range of Potential Population Growth . . . . .	80
43. Cumulative Energy Activity in the West . . . . .	82
44. proposed Split Basing Deployment Areas . . . . .	89
45. Summary Comparison of Long-Term Impact Significance Between the Proposed Action and Split Basing . . . . .	91
46. Vertical Shelter . . . . .	92
47. Transporter for Vertical Shelter . . . . .	94
48. Remove/Install Timelines for Horizontal and Vertical Shelters . . . . .	95
49. Dash Timeline for Horizontal Shelter. . . . .	96
50. Readable Transporter-Erector-Launcher . . . . .	98
51. Trench Layout . . . . .	99
52. MX Trench Concepts . . . . .	100
53. Minuteman/MPS Schedule. . . . .	102
54A. Population Subject to Fallout v. Wind Direction (Range: 500 rim). . . . .	103
54B. Population Subject to Fallout v. Wind Direction (Range: 1,000 nm) . . . . .	104
54C. Population Subject to Fallout v. Wind Direction (Range: 1,500 nm) . . . . .	104
54D. Population Subject to Fallout v. Wind Direction (Range: 2,000 nm) . . . . .	104
55. Downwind Distance v. Total Dose . . . . .	105
56. Crosswind Distance v. Total Dose . . . . .	105
57A. MX in Texas and New Mexico: Population Subject to Fallout v. Wind Direction (Range: 500 rim). . . . .	106
57B. MX in Texas and New Mexico: Population Subject to Fallout v. Wind Direction (Range: 1,000 nm) . . . . .	106
57C. MX in Texas and New Mexico: Population Subject to Fallout v. Wind Direction (Range 1,500 nm). . . . .	106
57D. MX in Texas and New Mexico: Population Subject to Fallout v. Wind Direction (Range 2,000 nm). . . . .	107
58A. Downwind Distance v. Total Dose — 500 KT . . . . .	107
58B. Downwind Distance v. Total Dose— 250 KT . . . . .	107

LIST OF FIGURES

<i>Figure No.</i>	<i>Page</i>
9. Multiple Protective Shelters. . . . .	33
10. Preservation of Location Uncertainty and System Design . . . . .	39
11. Peak Overpressure From I-MT Burst . . . . .	40
12. Surviving Missiles v. Threat Growth for MPS Example . . . . .	42
13. MPS Shelter Requirement for Projected Soviet Force Levels . . . . .	44
14. System Description . . . . .	46
15. Launcher . . . . .	47
16. Missile Launch Sequence. . . . .	47
17. Cannister Construction . . . . .	48
18. MX Protective Shelter Site . . . . .	49
19. MX Protective Shelter . . . . .	50
20. Transporter . . . . .	50
21. Missile Launcher and Simulator— Transfer Operations. . . . .	51
22. Mass Simulator and Launcher Exchanges . . . . .	51
23. Mass Simulator . . . . .	52
24. Cluster Layout . . . . .	52
25. Shelter and Road Layout . . . . .	53
26. Command, Control, and Communications System . . . . .	54
27. Electrical Power Distribution. . . . .	55
28. MX-Cannister/Missile Launch Sequence . . . . .	56
29. Transporter Rapid Relocation Timeline . . . . .	57
30. Dash Timeline . . . . .	58
31. Geotechnically Suitable Lands. . . . .	60
32. Road Construction Profiles . . . . .	62
33. Area Security . . . . .	63
34. Point Security. . . . .	63
35. Hypothetical MPS Clusters in Candidate Area . . . . .	65
36. Potential Vegetative Impact Zone. . . . .	71

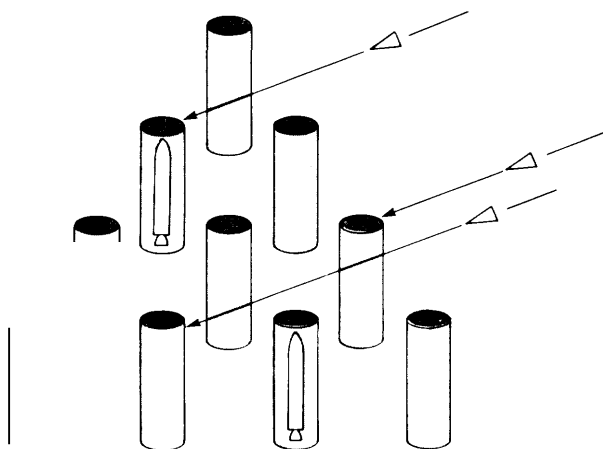
# MULTIPLE PROTECTIVE SHELTERS

## OVERVIEW

The multiple protective shelter (MPS) concept seeks to maintain the capabilities of a fixed land-based ICBM force, while protecting the force from Soviet attack, by hiding the missiles among a much larger number of missile shelters (see fig. 9). If the attacker does not know which shelters contain the missiles, all the shelters must be attacked to ensure the destruction of the entire missile force. Thus, the logic of MPS is to build more shelters than the enemy can successfully attack, or at least to make such an attack unattractive by requiring the attacker to devote a large number of weapons to attack a relatively smaller force.

In this chapter, the theory, design requirements, and some of the outstanding issues of MPS are addressed. In particular, the technical and operational requirements of hiding the missiles among the shelters, formally known as preservation of location uncertainty (PLU), are examined. This would be a new task for missile land basing, and it is now appreciated as one of the more challenging aspects of MPS. The compatibility of the missiles' location uncertainty with arms control monitoring is also discussed.

**Figure 9.— Multiple Protective Shelters (MPS)**



SOURCE: Office of Technology Assessment

Inherent in the strategy of MPS is that the number of shelters constructed be keyed to the size of the Soviet threat. Growth in the number of accurate Soviet warheads would require a larger deployment of missile shelters to maintain the same expected survival rate for U.S. missiles. The sensitivity of missile survival and shelter number to the size of the Soviet threat is discussed by performing several MPS calculations related to possible Soviet growth. The consequences of an "undersized" MPS are also examined, and shelter number requirements are calculated.

These issues, keeping the missiles successfully hidden and determining the proper size of the MPS, are common to any MPS-basing mode, and are analyzed in detail in the section on the theory of MPS.

Much of this chapter is devoted to specific designs for an MPS, with a great deal of attention devoted to the Air Force's baseline system. This system has been in full-scale engineering development since September 1979, and was modified in the spring of 1980 to include a horizontal loading dock configuration for the missile shelter. As proposed, the baseline system consists of 200 MX missiles among 4,600 concrete shelters, with each missile deployed in a closed cluster of 23 shelters. These shelters would be spaced about 1 mile apart and arranged in a linear grid pattern. Each shelter would resemble a garage, or loading dock, into which a missile could be inserted horizontally. Missile location uncertainty would rely on the use of specially designed missile decoys of similar, though not identical, physical characteristics to the real missile, and the employment of operational procedures that would treat missile and decoy alike. Large transport trucks could shuffle missiles and decoys among the shelters in order to keep the precise location of the missiles unknown to outside observers. Descriptions are provided of the layout and operation of this basing, mis-

sile mobility and the “dash” option, command, control, and communications (C3), and estimates for system cost and schedule Air Force criteria used for siting the MX, and its regional impacts are also addressed.

In the discussion of regional impacts, emphasis has been on two particular issues. Because the Air Force has already completed extensive studies and has published almost so volumes of materials (MX: Milestone II, Final *Environmental Impact Statement; Deployment Area Selection and Land Withdrawal Acquisition, Draft Environmental Impact Statement; and MX: Environmental Technical Reports*) relating to the environmental impacts of MX/MPS basing, no attempt has been made to catalog the potential environmental impacts, to evaluate independently all of those impacts identified by the Air Force, or to critique the Air Force environmental impact statements (EISs). Instead, those documents have been used as resources, and attempts have been made to draw attention to those issues that are believed to be of most importance to the congressional decision making process. For more detailed information on particular impacts associated with MPS, reference should be made to the Air Force EIS documents and comments by the States of Nevada and Utah.

A variation of the proposed system would be split basing, where the system would be deployed in two noncontiguous regions of the country: the Great Basin area of Utah and Nevada, and the border region between Texas and New Mexico. This basing scheme would mitigate the regional impacts, at some addition to system cost.

In addition to discussions of the Air Force baseline system and split basing, several alternative MPS designs are examined. All of these have been studied in the past, but rejected by

the Air Force for various reasons. These designs include housing the MX missile in conventional Minuteman-like vertical shelters, rather than the horizontal shelters of the Air Force basing. Greater hardness against nuclear attack could be achieved with vertical shelters; however, missile mobility would be somewhat simpler with horizontal shelters.

Two previous baseline modes for the MX are also discussed: the “trench” design, where the missile would reside in a long concrete-hardened tunnel several feet underground, and the so-called “roadable TEI,” the immediate predecessor of the present baseline, where the missile and transporter were structurally integrated, and therefore had greatly enhanced mobility.

Another possibility would be the deployment of *Minuteman III* missiles in an MPS mode, by constructing a large number of additional vertical shelters in the present Minuteman missile fields. Proponents of this system claim it would provide an accelerated schedule for a survivable land-based missile force, since Minuteman missiles, support infrastructure, and most roads are already available. Modifications to the Minuteman missile would be required to deploy it in a mobile mode, and many additional shelters and missile transporters would need to be built. The extent of these and other modifications is addressed, as is system cost and schedule for completion.

Finally, several calculations of civilian fatalities resulting from a Soviet attack on MX deployment in multiple protective shelter fields are presented. These calculations help address the question of the extent to which a Soviet strike against an MPS deployment could indeed be regarded as “limited.”

## THEORY OF MULTIPLE PROTECTIVE SHELTERS (MPS)

A land-based missile force in MPS relies for its survivability on the assumption that the attacker, in order to destroy the adversary's mis-

sile force with confidence, will be forced to target all or most of the shelters if it is not known which of these shelters contains the

missiles. MPS thus tries to draw a distinction between missile and target, by “immersing” the missile force in a “sea” of shelters.

MPS can also be regarded as “anti-MIRV” basing. Just as MIRV (multiple independently targetable reentry vehicle) technology allows one to attack many targets with one missile, MPS forces the attacker to devote many warheads to destroy one real target.

For this strategy to work, the tasks of “hiding” the missiles among the shelters and properly sizing the MPS system for a given level of survivability involve two key requirements. Since the nature of these two tasks is similar for all MPS basing modes, their details and implications are discussed in this section of the chapter.

### Preservation of Location Uncertainty (PLU)

Inherent in the strategy of MPS is that all shelters appear to the attacker as equally likely to contain a missile. This assumption is important, since if the attacker were to find out the location of all the missiles, it would defeat the design of the system. For the planned 200 MX missile deployment, for example, it could mean targetting as few as 200 reentry vehicles (RVS), one RV per MX missile, which is a small portion of the Soviet Union’s arsenal. The task of PLU — or keeping the missile location secret — is essential to successful MPS deployment. With increased study of this issue over the last few years, the defense community has come to realize the magnitude of the PLU task. What makes PLU so challenging is that it is a many faceted problem, dealing with a variety of missile details. Moreover, PLU must be made an integral part of the design process at every level. Furthermore, the present expectation is that the design process for PLU will be ongoing throughout deployment, with continuous efforts at enforcing and improving missile location uncertainty through improved PLU countermeasures and operations,

To accomplish this task of missile concealment, it is necessary to eliminate all indica-

tions, or signatures, that could give away the location of the missile. One such set is the set of all physical signatures of the missile and associated missile equipment. This set includes weight, center of gravity, magnetic field, and many others. By utilizing these physical signatures, missile location might be inferred by making measurements outside the shelter or missile transporter, looking for those signatures that could distinguish location of the missile. Such signatures span the spectrum of physical phenomena, many with a range of detectability of hundreds of miles, if not adequately countermeasure.

A second set of missile signatures to be eliminated are operational signatures. The task here is to eliminate all operating procedures that could distinguish the missile and thereby betray its location. Otherwise, missile placement might be inferred by observing personnel operations.

Internal information is a third set of signatures. This set includes the piecing together of many observations to arrive at a pattern recognition of data from which one can infer missile location.

Soviet espionage efforts aimed at breaking PLU will also be likely, and counterintelligence efforts may be necessary.

## Signatures

### PHYSICAL SIGNATURES

The physical signatures of the missile run into the scores, with the magnitude and range of each dependent on design details and material construction of the missile, shelter, and transporter. Against each of these signatures that might compromise missile location it is considered desirable to design and install a set of specific countermeasures. These countermeasures include simulating missile signatures with decoys, masking or reducing the magnitude and range of the signatures, and confusing an outside observer by engineering a set of signatures that vary randomly from decoy to decoy in order to make it more difficult to determine which shelters contain the missiles.



Table 2 is a generic list of associated missile signatures present for any MPS system. A brief discussion of them is included here along with some possible countermeasures. A more detailed list and analysis is included in the classified annex.

1. Seismic/ground tilt results from the force of missile weight on the ground, both as seismic waves set up by the motion of the missile in transit, and static measures of its mass, such as the tilt of the ground in the missile's proximity. The seismic signature is particularly significant while the missile is in transport between shelters, since seismic waves can propagate for miles, with a falloff in wave amplitude that varies inversely with distance. Ground tilt caused by depression of the ground under the missile-laden transporter falls off somewhat faster with an inverse square law, and a maximum ground depression of the order of thousandths of an inch. The resulting ground tilts are measurable at a distance. A countermeasure for this signature may include a mass decoy.

2. Thermal sources arise from heat generated by electrical equipment associated with the missile, such as fans, heaters, and other environmental control systems. A measure of this heat is the power consumed by each shelter, typically 10 to 20 kilowatts (kW) at full operating power. Countermeasures for this signature might use thermal insulation and dummy powerloads at the unoccupied shelters.

3. Acoustic sources are due to such items as cooling fans and missile transfer operations at the shelter site. This signature might be countermeasured by simulation, such as suitably placed recording and playback devices.

4. Optical signatures are significant primarily while the missile is in transport. Assuming that the transporter is covered, so that the missile is not directly visible, concern must be shown for the modal oscillations of the missile transporter in a loaded v. unloaded condition, tire deformation, exhaust smoke, and vehicle sway angle around corners. Sensors that might pick up this distinction range from sophisticated optics aboard a high flying plane to ground-based lasers or even observation with binoculars at a distance. A possible countermeasure for this signature is a massive decoy of the same weight and similar vibrational characteristics to the missile.

5. Chemical signatures are due to the routine volatile chemical release from the missile, such as propellant, coolant, plasticizers, and ozone. The missile transporter exhaust may differ for a loaded v. unloaded case. Chemical concentrations are expected to be as high as 1 part per million (ppm), and methods of detection include laser scattering infrared absorption, Raman spectroscopy, and taking onsite samples for later analysis. Countermeasures may include simulated effluents and a massive decoy load for the missile transporter.

6. The nuclear warhead on the missile has its own signature characterized by a set of gamma ray spectral lines particular to the plutonium isotopes contained in it. The warhead material also emits neutrons. Useful countermeasures include radioactive shielding.

7. Radar is a potential signature due to the large radar cross section of metal objects associated with the missile, such as launch equipment. In addition, distinguishing the modal oscillations of the transporter due to different loads may be radar detectable from a distance of several hundred miles. Countermeasures for radar include a massive missile decoy, and reliance on the metal rebar and a steel line for the shelter as well as earth overburden to radar-shield its contents.

8. Gravity field and field gradient measurements should be able to detect the mass of the missile at a range of several hundred feet.

**Table 2.—Physical Signatures of Missile**

•Seismic/ground tilt	•Nuclear
•Thermal	•Radar
•Acoustic	•Gravity
•Optical	•Magnetic
•Chemical	•Electromagnetic

SOURCE: Office of Technology Assessment

Mass simulation is the most direct countermeasure to this threat

9. Magnetic field anomalies due to the large amounts of metal in the missile-launching equipment, if unshielded, can be detected by a magnetometer. Such detection techniques are analogous to magnetic anomaly detection of submarines, and similar countermeasures can be utilized. A missile decoy containing an appropriate quantity and distribution of high permeability (magnetic) metal might be used to help prevent an observer from distinguishing it from the missile.

10. Electromagnetic emissions generated by missile equipment during normal operations are another potential signature. In addition, radio frequency communication involving the missile could lead to missile location determination by radio direction-finding techniques. Electrical transients may also be detectable. Countermeasures to these signatures might consist of simulating powerline consumption by installing dummy loads inside the shelter, and communicating with the missile during normal operation over secure buried cable, rather than radio.

The task for a potential attacker to defeat MPS by utilizing these signatures depends on the range of the signature to be exploited, the covertness needed to collect and transmit the data, and the degree of security provided for the MPS deployment area. Presently planned security arrangements for the shelters are commonly referred to as point security. Point security allows public access to all but a small restricted area around the shelter, and therefore allows access relatively close to the missile shelter. Area security, on the other hand, would restrict access to most of the deployment area.

Designing PLU for short-range observation, which is anticipated for point security, is more demanding than for long-range surveillance, since most, though not all, of the missile signatures are significantly stronger at close range. For example, magnetic anomaly detection, which relies on measurement of magnetic field gradients, falls off as the inverse cube of

the distance from the source. This means that the strength of this signature at 100 ft is more than 1 million times as intense as this signature would be at some 2 miles away. Since close-in the magnetic details of the source become more important, the distribution of magnetic material in the decoy is more critical for adequate deception than it would be for distant observation.

In addition to the short-range signatures, there are also long-range signatures, such as detailed motions of the missile transporter and seismic waves, that are measurable at many miles.

The range of missile signatures strongly determines the degree of covertness that an agent must employ to collect missile location information. A signature that is visible at long ranges might require little or no cover to observe. In particular, long-range signatures would be particularly threatening if observable by satellite, since security would have little effect; and the impact on PLU would be catastrophic if such signatures could not be successfully countermeasured. Similarly, signatures that are measurable at several miles or tens of miles are also particularly threatening, since security sweeps would be impractical over so large an area, even if possible. In the case of long-range surveillance, the number of sensors needed would be small compared to the number of shelters, with the precise number dependent on signature range. It is not clear whether covert operation of sensors would pose a problem to the Soviets if they found a signature that was observable at such ranges. On the other hand, short-range signatures would require some degree of covertness, perhaps by an implanted sensor, a roadside van, or "missile sensing" done under the guise of another activity, such as mining. Once missile location is determined there are a number of ways to transmit the information covertly.

For short-range shelter surveillance, many emplaced sensors, on the order of thousands, would be necessary to seriously degrade PLU, since a large portion of the shelter deployment

would require independent observation. This task could pose a severe problem for the enemy agent. In addition, the areas proximate to the shelter would quite likely be subjected to frequent sweeps by security forces. On the other hand, covert sensors that could detect missile presence in the transporter, while the missile is in transport, could be much more serious. Since point security would not secure the roads, implants in the roads must be prevented from determining the contents of the transporter. In a linear cluster arrangement, for example, if PLU on the transporter were to fail, then *one* missile-sensing device planted in the middle of the cluster would be able to determine which half of the cluster contained the missile, thereby effectively reducing the number of shelters in half. Therefore, PLU is particularly important for the transporter, and it must be constantly supplemented by security sweeps of the road network.

The Air Force program for dealing with physical missile signatures consists of several approaches, the first of which is to eliminate the signatures, if possible, by system design. For example, if one construction material has a smaller signature than another, using the first material might be preferable. An example of this might be the use of nonferromagnetic material, if practical, rather than iron, in order to reduce or eliminate the magnetic signature.

These technical design requirements due to PLU have been established for the launcher, the mass simulator, the protective shelter, and the transporter. The list of these requirements needed to countermeasure the missile/launcher signatures, some of which were listed in the previous section, and the many others that are system-particular, is a very long list, that is discussed more fully in the classified annex to this section.

The second approach to countermeasure physical signatures after attempting to design them away could be to attenuate the signature by shielding. For example, heavy material shields gamma radiation. Thermal insulation might be used for heat signatures, and so forth.

A signature that cannot be designed away or attenuated might conceivably be masked or jammed. For example, a real signature that is measurable might be masked by an additional large, possibly random signal, thereby making it more difficult to extract the real missile signature from the "noise."

If these approaches were not feasible, an attempt to simulate the signature by the use of a decoy might be employed. This simulation is one of the purposes of the MX mass simulator, which will be placed in all of the unoccupied shelters, and in the transporter when simulating missile transport. Since the simulator is designed to weigh the same as the missile/launcher, it automatically countermeasures those signatures that arise from total weight.

As discussed in the classified annex to this section, additional simulations will be required.

Finally, there can be physical security for the deployment area that would consist of monitoring the area and sweeps for sensors that might compromise missile location.

#### OPERATIONAL SIGNATURES

In addition to physical missile signatures, it is necessary that routine procedures of missile transport and maintenance do not expose the location of the missile. This consideration means that when carrying out missile-related and mass-simulator-related operations, personnel must do the same things, in the same time interval, with the same equipment at all sites. For example, when it becomes necessary to return the missile from maintenance to the shelter, the transporter must visit all of the shelters and either deposit or simulate deposit of the missile. If the operator knows in which shelter he is depositing the missile, care must be taken that any actions on his part, such as outward behavior or conversation with colleagues, do not give clues to missile location.

#### INTERNAL INFORMATION

This category includes piecing together many observations to arrive at any pattern recognition of data from which one may infer missile location. To deal with this considera-

tion, the Air Force has set up a special compartment for PLU-sensitive data. Special access would be required to acquire this information. In addition, operational personnel will be constrained in their knowledge of missile locations. Under normal circumstances, maintenance and operational personnel will know the locations of only a small percentage of the missile force and the contents of the shelters.

### PLU Design Process

Since the scope of PLU design is so broad, and the threat to PLU adaptive, the Air Force's overall approach to this task would be an iterative process (see fig. 10). Starting from the system baseline defined at a particular time, work would proceed to characterize missile signatures and the threat to the system, in terms of sensors available to the enemy and their access to the system. From these assessments, a determination of potential signatures would be made that offers a discriminant for the missile. Countermeasures would be developed, selected, and tested. Those countermeasures chosen would be made part of the new baseline. This process would then repeat itself. Thus, PLU work must be a continuing process, with signature characterization and needed mitigation an ongoing effort. In terms of schedule, signature testing on system components is underway now. Small scale testing for signatures will be done in the latter half of

1981 through the Spring of 1982, with full-scale testing in the latter part of 1982 through 1983. These tests will be critical in the design of the transporter and mass simulator, as well as for the entire PLU task.

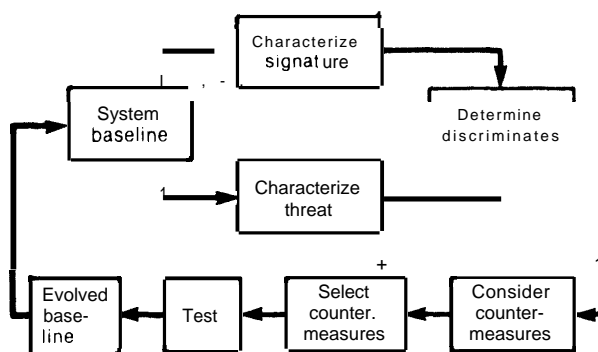
### Assessment of PLU

Assessing the feasibility of the PLU effort is a difficult task. First, it is a genuinely new problem, and not a simple extrapolation of past engineering efforts. Since missile signatures and their countermeasures sensitively depend on the detailed design of the system, it is difficult and can be misleading to make general statements about PLU.

No physical analysis is known that can argue that PLU is a physically impossible task. Its analysis and countermeasures rest on well-understood physical principles. Until recently, however, there has been no research and development program on PLU, nor have there been full-scale field tests to validate many of the conjectures and analytical tools needed to design the system. In terms of PLU's scope, its detail-intensive character, and simply as a new technical problem, comparable previous experience or data are not available to guide in judging its feasibility. It is true that there is some analogy with submarine detection and location. Indeed, some PLU signatures, most notably magnetic, are common with submarines. Still, there are two important distinctions. First, in antisubmarine warfare (ASW), there is no present need to discriminate the actual submarine from a decoy, although resolving a submarine signature from a noisy background may be one of the lead tasks. Second, at a technical level, the details confronted with PLU and ASW are quite distinct. The environments and media are different, and the relevant signatures and the available distance at which the measurements can be performed are different (much closer for MPS). Si reply stated, solving the technical ASW problem does not significantly help solve PLU, and vice versa.

In addition, it is not known at this point of technical PLU work, how feasible it will be to

Figure 10.—Preservation of Location Uncertainty and System Design



SOURCE: U.S. Air Force.

eliminate, attenuate, mask, simulate, or randomize *all* of the missile's signatures, or what the residual signatures will be. Since this is a detailed engineering task, confidence cannot be obtained until full-scale field tests have been done, when missile signatures can be more reliably identified and analyzed.

Thirdly, it may not be possible to be certain that PLU has not been broken by the Soviets; a break (or even a small fracture) of PLU may likely be a silent event. For all the scores of signatures that have been successfully counter-measured, it takes only one accessible uncountermeasured signature to imperil the survivability of the entire missile force. On the other hand, it is reasonable to expect that personnel running a vigorous program to monitor PLU in operation will be more aware of compromises in the system than an outside agent would likely be. Furthermore, a compromise in PLU would not necessarily be catastrophic, since a breach in PLU for several shelters or even several missiles would not significantly threaten the entire force. In any case, confidence in our having PLU is an important factor in its own right. In addition to being based on knowledge of our own system, confidence is also a state of mind, and not always easy to judge or predict,

Finally, the extremely high value of the knowledge of missile location must be emphasized. Because this knowledge holds the key to MX survival in a Soviet attack, a vigorous Soviet effort in this area should be expected, underscoring the technical and operational importance of the PLU effort. The Air Force effort for PLU, which several years ago may have underestimated its scope and difficulty, has more recently proceeded with a program that is comprehensive and realistic in its approach. However, whether this or any other program will succeed in developing a technology that will successfully keep the missile hidden is a technical assessment that cannot be made at this point, at least until full-scale hardware exists and can be tested for all missile signatures,

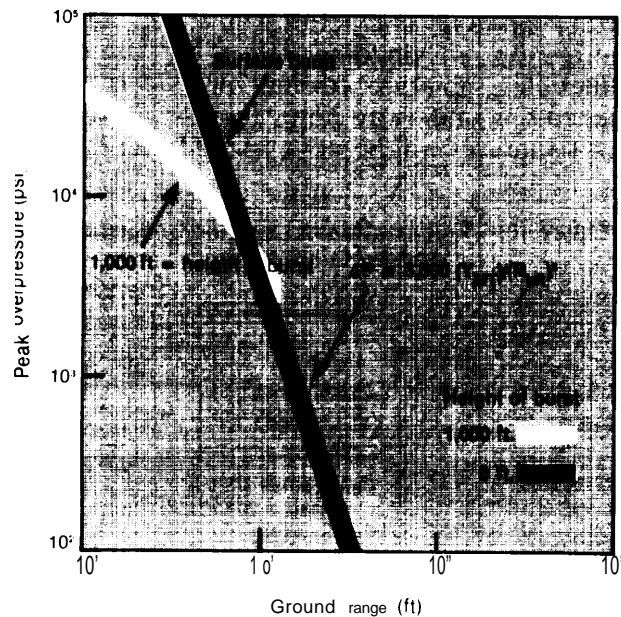
## Sizing the MPS System

For MPS to provide a given degree of survivability to its missile force, an adequate number of shelters must be deployed so that the entire system can absorb an attack, and still leave the required fraction of the missile force intact. Determining the number of shelters to be built and the deployment area of the system depends on a number of factors: the hardness and spacing of the shelters, the accuracy and reliability of enemy missiles, the number of threatening warheads, and the size and survival requirements of the U.S. missile force,

Since the idea of MPS is not to build a shelter that can survive a direct hit, but one that can survive the effect of direct hits on its neighboring shelters, the requirements for shelter hardness are much less than for the typical Minuteman silo.

The overpressure experienced by the shelter depends on its distance from the nuclear detonation(see fig. 11). For any MPS system,

Figure 11 .— Peak Overpressure From 1-MT Burst



SOURCE RDA

there is a tradeoff between shelter hardness and shelter spacing. The harder the shelter is made, the closer the shelters can be spaced and still withstand the effects of nearby nuclear detonations. Conversely, the farther apart the shelters are spaced, the less hard the shelters need be made. In practice, the shelter spacing and hardness combination is determined by cost trade-offs between increased shelter hardening (that requires a larger shelter and more concrete) and increased shelter spacing (that requires more roads and buried communications and electrical connections between shelters), in order to reach a cost minimum solution.

The reliability and accuracy of enemy missiles are also important factors for deciding how many protective shelters to build. Reliability is the probability that the missile, when given the order to fire, will fire and operate properly along its trajectory. When planning for shelter deployments, more shelters will clearly be needed for a high enemy missile reliability than for a low one. Missile reliabilities are typically between 0.8 and 1.0, and their effect on vulnerability calculations will be illustrated later in this section.

Missile accuracy is a measure of the missile's ability to land a nuclear warhead on its target. Typically, missile accuracy is measured in terms of CEP, or circular error probable. CEP is defined as that distance from the target within which half of the warheads would land if targeted. A large CEP means a less accurate missile; a small CEP means a more accurate missile.

Missile Accuracy depends on a variety of factors, both internal and external to the missile. The heart of the missile's guidance lies in its inertial measuring unit (IMU). Placed in the upper stage of the rocket, the IMU senses missile accelerations throughout the boost phase, integrates the signals to get velocity and position data, and uses this data to navigate the missile to the warhead's release point. Contributions to target miss, called the error budget, include the following items:

- small errors of instrumentation and calibration,
- knowledge of initial position and velocity of missile,
- IMU platform alignment,
- knowledge of gravity for the launch point region and missile trajectory,
- knowledge of target location,
- RV separation from the missile bus, and
- errors during atmospheric reentry.

Knowledge of the missile's CEP and reliability, and the hardness of the target, allow the probability to be calculated that the target will be destroyed in an attack. There are standard tables for this calculation, but for present purposes, the following formula is adequate for the probability that a reliable RV will destroy its target, or  $p_k$ :

$$P_k = 1 - \exp\left[-\frac{YH}{2(CEP)^2}\right]$$

where

$P_k$  = the probability of kill

$Y$  = the yield of the weapon, in megatons

$H$  = the hardness of the shelter, in thousands of psi

CEP = circular error probable, in kilofeet (thousands of ft)

For example,

Yield  $Y = 1$  MT

Hardness  $H = 600$  psi (or  $0.6$  thousand psi)

CEP = 1,800 ft (or 1.8 kilofeet)

then

$P_k = 50\%$  (or 0.5)

This answer corresponds to the fact that the 600 psi contour for a 1 MT detonation occurs at the 1,800-ft contour. Since, by definition of CEP, half of the time the weapons would fall within 1,800 ft of the target, and half of the time they would fall outside 1,800 ft, then the probability of kill is exactly so percent.

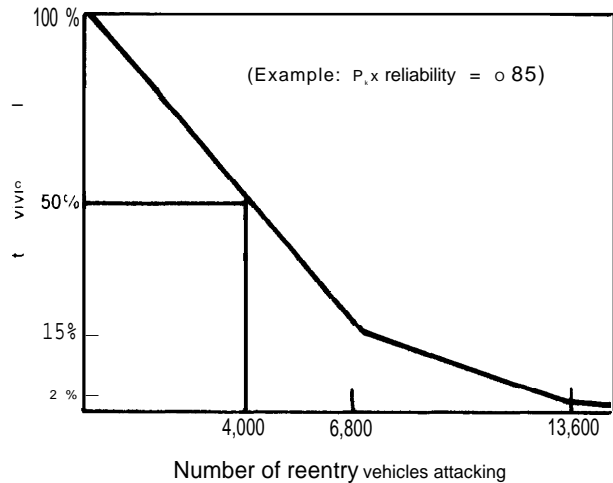
Typically, modern intercontinental ballistic missile (ICBM) accuracy is much better than this, and for shelters of hardness less than 1,000 psi, the probability of kill (given the proper yield) is close to 100 percent (or 1.0). Furthermore, the future trend is for  $p_k$  to be so close to one that the expectation of destroying almost any such target is approximately equal to the reliability of the attacking missile.

### An MPS Calculation

A typical MPS calculation is now performed. Suppose the reliability of the attacking missile times its Pk (which is the expectation of destroying the target) is 0.85, for example. Suppose further that there are 4,000 attacking warheads of I-MT yield each. The expectation is that this attack can destroy  $(4,000) \times (0.85) = 3,400$  shelters. Therefore, after such an attack, an MPS force of 6,800 shelters would have half of the shelters remaining. Without the attacker's knowledge of missile location it could be expected that half of the missile force would also survive (see table 3).

To address the sensitivity of missile survival to the size of the threat, using the above example as a base case, the percentage of surviving missiles v, number of threatening RVS is shown here in figure 12. As before, a reliability of 0.85 and a pk close to one is assumed. The number of surviving missiles falls off linearly with increasing numbers of attacking RVS at the rate of 0.85 shelters per RV, until RV number equals shelter number, 6,800. At this point, 1,020 shelters would remain, or 15 percent of the missile force would survive. If the attacker chooses, and if he has the warheads, he can attack with a second round of RVS. Assuming that he does not know which shelters he destroyed during the first round, he attacks all of the shelters again, with a 15-percent efficiency of targeting among the shelters that are still standing (since 15 percent of the shelters survived after the first round). Ideally the second slope is 15 percent of 0.85, or 0.1275 shelters destroyed per RV, but fratricide effects (be-

**Figure 12.—Surviving Missiles v. Threat Growth for MPS Example**



SOURCE Office of Technology Assessment

tween the first and second rounds) might flatten out this second slope significantly.

The rationale for MPS in this hypothetical example can be seen in the following way. Suppose the MX missile were deployed in an MPS with a ratio of 1 missile per 34 shelters. This deployment includes a total of 200 MX missiles, with 2,000 Mk 12A warheads. It would take, on the average, 34 perfect attacking RVS to destroy an MX missile with its 10 warheads, or a ratio of 3.4 attacking RVS to destroy 1 MX RV (assuming we had perfect PLU). This ratio would be in contrast to undefended silo basing, where it would take at most two RVS (for a much harder shelter), to destroy 1 MX missile with its 10 RVS, or a ratio of 1 to 5, in favor of the attacker.

### Shelter Requirements

This discussion is completed by addressing actual MPS shelter requirements for the MX set by the size of the possible Soviet threat. As discussed earlier, any MPS system is sized, in part, to the opposing threat; there is no absolute number of shelters that will guarantee safety for the missile force, but only a number relative to the opposing number of nuclear warheads. Therefore, for MPS to be survivable, it should be keyed to and keep pace with the evolving Soviet threat. Given the size and char-

**Table 3.—MPS Example**

Assume:	
•200 MX missiles	
•4,000 attacking warheads	
•0.85 probability of kill times reliability	
Requirement:	
•50% survival of missile force	
Shelters vulnerable:	
• $4,000 \times 0.85 = 3,400$ shelters	
Shelters required:	
• $3,400/50\% = 6,800$ shelters (assuming perfect PLU)	
SOURCE Office of Technology Assessment	

acteristics of this threat, the calculations for shelter number are straightforward, as illustrated by the above example.

The present Air Force baseline MPS system would deploy 200 MX missiles in 4,600 shelters, with a shelter to missile ratio of 23 to 1. This system size has been related to a projected Soviet threat of approximately 3,000 accurate RVs targeted exclusively against MX. This projection assumes that: 1) Soviet warhead number is constrained by arms control agreement, and 2) within these constraints, the Soviet Union did not attempt to make an all-out attempt to overwhelm the 4,600 shelter MPS. If the above assumptions on Soviet restraint are relaxed, then the threat against MPS will grow past the nominal 3,000 RVs, and the system will *need* to respond if it is to maintain its chosen requirement for survivability. This response can take the form of building more shelters, more missiles, a cost-optimum combination of the two, or a ballistic missile defense of the system, such as a low altitude defense system (LoADS), that is discussed fully in the next chapter.

Projections for Soviet forces devoted against MX depend, in the first case, on what the Soviets decide to do with their nuclear forces. One possibility is that they concentrate their efforts to address the vulnerability of their own ICBM forces. This concentration could take the form of a mobile missile, an MPS system similar to what we have discussed, ballistic missile defense, and perhaps other measures such as very hard shelters. Alternatively, the Soviets might decide to concentrate their efforts on a counterforce capability against MX. This counterforce could take the form of modifying their present modern missiles (particularly the heavy SS-18) to carry a larger number of smaller yield warheads (called fractionation). A third possibility is a mix of the two routes described above: part addressing their own vulnerability and part counter-MX.

Any effort to estimate the size and composition of future Soviet forces is highly uncertain—our intelligence is far from perfect, and in some cases the Soviet leaders themselves

may not yet have made key decisions. An approximation of the threat has been sought, however, by making a series of conservative assumptions, including:

- continuation of 1970's trends in Soviet ICBM development and deployment,
- no major breakthroughs in ICBM technology,
- no constraints imposed by shortages of critical nuclear materials, and
- SLBMs not used to target U.S. ICBM silos or shelters.

These assumptions amount to projecting the trends of the 1970's through the 1980's and into the 1990's. On this basis, an attempt has been made to estimate the number of Soviet RVs whose reliability, accuracy, and yield would be good enough to give an 85-percent probability of destroying an MX missile in a targeted shelter with a single shot.

It is estimated that the Soviets could have 6,000 to 7,000 RVs available to attack MX by 1990, and 11,000 to 12,000 RVs available by 1995. By 2000, the Soviet RV inventory could be so large that 15,000 or more could be aimed at an MX deployment. Furthermore, this rate of deployment would not require a greater Soviet effort to improve their ICBM force in the 1980's and 1990's than the effort they devoted to this purpose in the 1970's. In the face of the above Soviet threat, the baseline deployment of 200 MX missiles in 4,600 shelters simply will not suffice.

To give an example of the needed system expansion, a characteristic case is chosen: 7,000 Soviet RVs targeting MX by 1990, and 12,000 RVs by 1995 (it is assumed that in a first strike, the Soviets will expend approximately 3,000 RVs for 2-on-1 attacks against Minuteman silos and other U.S. strategic targets). The United States responds with a deployment designed to guarantee the survival of a fixed number of MX missiles, that is chosen to be 100 MXs as a representative number. Within this constraint, there is a continuous set of solutions that mix increased missile number and shelter number. In practice, cost optimization may be used to choose a missile/shelter ratio, and calculations



based on actual MX cost models suggest that the ratio of 1 to 23 is not far from cost-optimum. Shelter number requirements are shown in figure 13. This graph shows that for an undefended MPS, approximately 8,000 shelters will be needed by 1990, and that by 1995, an adequate MPS will require approximately 12,500 shelters. (The knee in the curve occurs on the chart where reliability alone guarantees the required number of surviving MX missiles.)

Past the point of 8,000 to 9,000 shelters, it may be decided to deploy a ballistic missile defense, such as LoADS. It will become apparent that LoADS effectively doubles the price that the attacker must pay to destroy an MX missile in an MPS deployment. Therefore, if LoADS performs properly, an 8,000 shelter deployment with LoADS defense would be equivalent to a 16,000 shelter, undefended MPS deployment, and is commensurate with our projections for Soviet threat growth in the 1990's,

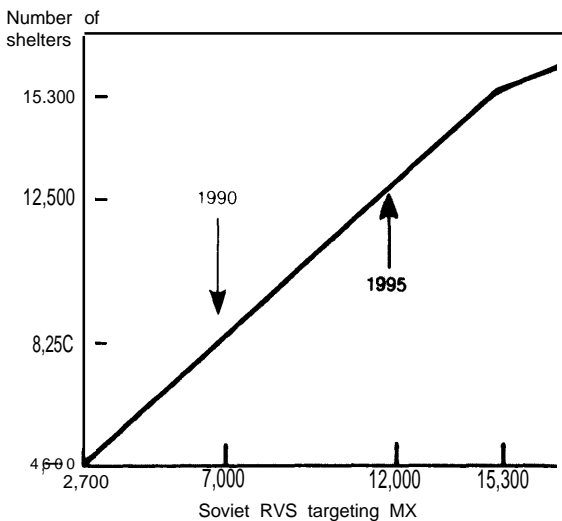
In addition to properly sizing the MPS system, it is also necessary that it keep pace with the expanding Soviet threat, so that it is large enough to meet the threat at any given time in its deployment. An expanding MPS that lags behind the Soviet force growth is not an effective deployment. Therefore, the rate of shelter construction should be chosen to keep up with the expected rate of Soviet growth. For an 8,000 shelter requirement by 1990, and an IOC (initial operating capability) for 1986, it would mean building shelters at the rate of 2,000 per year, instead of the presently planned rate of about 1,200 per year. After 1990, additional shelters would need to be built at the rate of about 1,000 per year. Alternatively, a LoADS defense would need to be installed. It should be pointed out that the decisions on shelter construction rate and LoADS defense are long-leadtime items, and the decision to proceed would need to be made several years prior to construction.

### Weapon Characteristics for MPS

Because the MX missile is stationary in an MPS basing, except for the periodic relocations during missile maintenance, the weapon's characteristics are essentially the same as fixed-silo ICBM basing. Thus, the system possesses a very high alert rate. It also has a quick and flexible response with a very hard target capability. The communications systems available are many and redundant, including land lines during peacetime and wartime radio links. Furthermore, the missile force is not dependent on strategic or tactical warning, unlike the bomber/ALCM leg of the Triad. It also has the highest potential for endurance and is capable of operating in a dormant (low power) mode for long periods of time with self-contained power supply (batteries),

Moreover, fixed land-based ICBMS have traditionally set the standard for missile accuracy, for several reasons. Recalling the previous list of contributions to missile CEP,

**Figure 13.— MPS Shelter Requirement for Projected Soviet Force Levels (100 Surviving Missiles)**



- Assumptions
- 1 missile for every 23 shelters
  - Damage expectancy 0.85

SOURCE Office of Technology Assessment

three relevant items are. 1) knowledge of initial position and velocity of the missile, 2) IMU platform alignment, and 3) the value of gravity in the launch point region and along the missile's trajectory. Because the missile launch position is fixed, its position and velocity are known with great precision. Similarly, being stationary easily allows the IMU to keep track of its alignment. In addition, gravity maps need to be prepared for the limited area in the proximity of the launch point. These items tend to make pure inertial guidance much

simpler for fixed missile basing than for continuously mobile basing that must update position coordinates and velocity by external aids if sufficiently accurate gravity data are not available.

For MPS, once the missile is relocated, the guidance platform needs to go through a recalibration and realignment. The requirement to reacquire CEP (i.e., highest accuracy) after relocation is 2 hours.

## THE AIR FORCE BASELINE

The Air Force baseline system for the MX missile is an MPS system for a force of 200 MX missiles to be deployed in the Great Basin region of Utah and Nevada. It would deploy these missiles among 4,600 hardened concrete shelters, a ratio of 23 shelters per missile. In the present design, the shelters would be laid out in clusters of 23: one missile per cluster; 200 clusters in all. Large, specially constructed transporter trucks would move the missiles within the cluster to help preserve location uncertainty and to transport the missile to maintenance when the missile is in need of service.

The present schedule calls for an initial operating capability (IOC) of 10 clusters (10 MX missiles in 230 shelters) for 1986, and a full operating capability (FOC) for the complete system in 1989: an average construction rate of about 1 cluster per week, or 1,200 shelters per year. Testing of the missile itself is planned to begin early 1983, with a schedule of 20 flight tests before IOC.

This section begins with a detailed design description of the system, including missile and launcher equipment, shelters, transporter, and cluster layout. Land use requirements, based on siting criteria, needs of physical security, and other elements of the system are discussed, as are the regional impacts, both physical and socioeconomic, water availability, and impacts on regional energy growth. Finally, system schedule and cost for the current baseline system and the expanded systems

are analyzed. The section is concluded with a treatment of a split-basing mode for MPS.

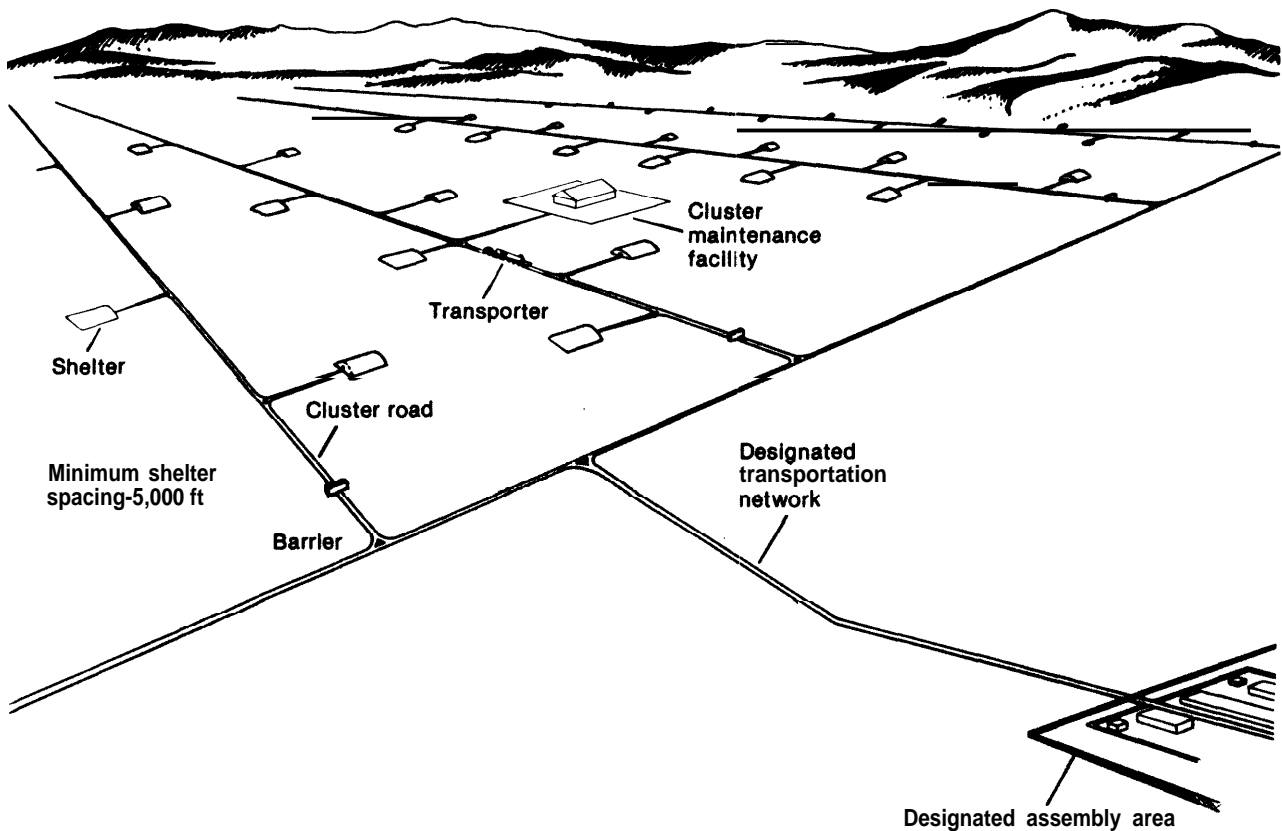
Discussions of preservation of location uncertainty (PLU) for the missile, and determining adequate shelter number, i.e., sizing the MPS, are covered in the previous section on the theory of MPS.

### System Description

Figure 14 shows the general layout of the deployment and assembly area.

The missile is first assembled in an area outside the deployment area. The missile is assembled stage by stage, into a close-fitting missile cannister, that provides environmental control, allows for ease of handling during transport, and supports "cold" launch ejection from the capsule. This cannisterized missile is then joined with a specially constructed missile launcher. The launcher (fig. 15) that is deployed along with the missile as a structurally integrated unit, consists of the launching mechanism that erects the missile for launch, radio receivers for communication, and survival batteries after an attack. The launcher also contains an environmental control unit for continuous temperature, humidity, and dust control. The launcher-missile assembly is designed to weigh about 500,000 lb, and it is introduced into the shelter cluster where it is deposited in the cluster maintenance facility (where minor repairs also can be performed

Figure 14.—System Description



SOURCE U S Air Force

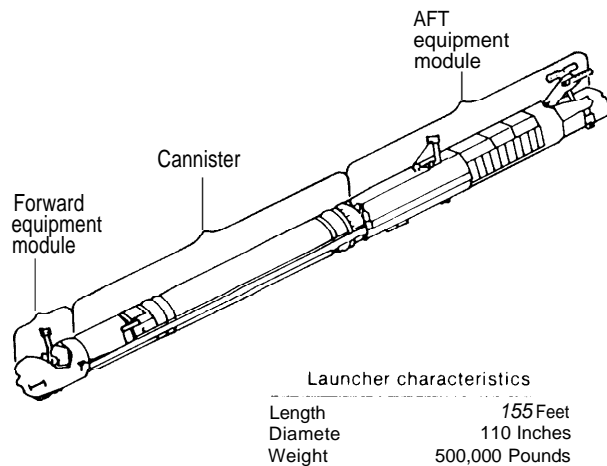
when necessary). From the cluster maintenance facility, the launcher/missile unit is then moved to its protective shelter via a specially designed and engineered transporter, which is also assembled in the assembly area and moved to its own cluster. In the current design, each of the 200 clusters will have one cluster maintenance facility and one launcher-missile transporter, for a total deployment of 200 cluster maintenance facilities and 200 transporters. Alternate designs under consideration call for "clustering the clusters," so that fewer cluster maintenance facilities and transporters, perhaps one quarter of those that are presently planned, will need to be deployed.

Once the missile is placed in its shelter it remains there until movement is necessary,

either for reasons of missile or launcher maintenance, changing missile location if necessary for preservation of location uncertainty, or for arms control monitoring by satellite. The same transporter also installs a missile/launcher decoy, called a mass simulator, into the other 22 shelters that do not contain a missile. The purpose of the mass simulator is to make it impossible for an outside observer to determine whether a missile or a mass simulator is in a given shelter (or transporter), at a given time, by duplicating many of the physical characteristics of the missile with launcher.

Throughout the missile deployment area thousands of miles of roads would be constructed to connect the shelters, clusters, and assembly area; in addition, thousands of miles of underground fiber optic cable would pro-

Figure 15.—Launcher

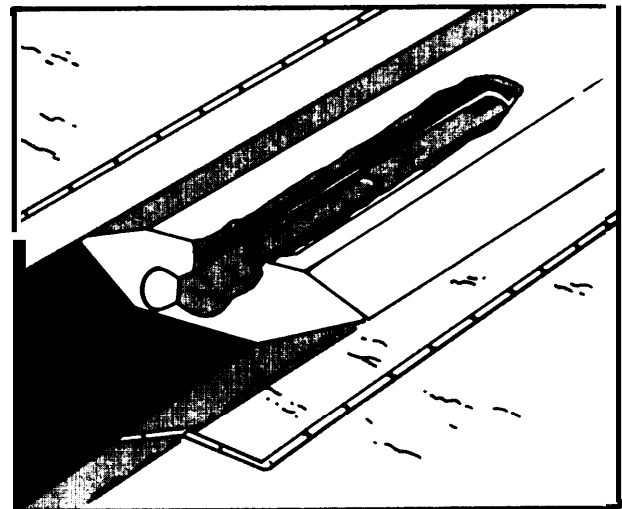


SOURCE U S Air Force

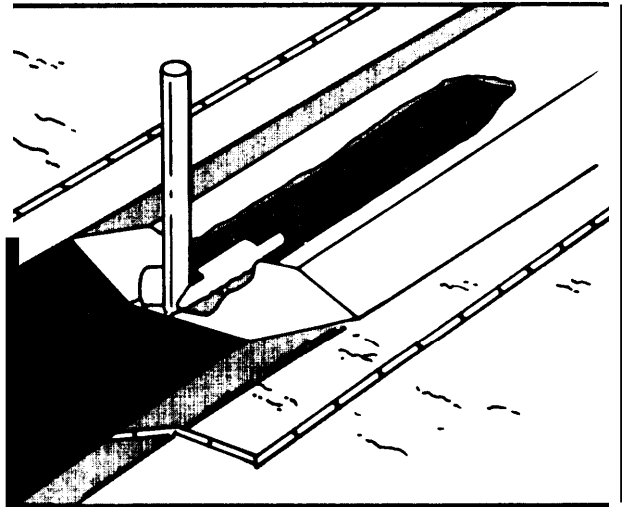
vide peacetime communication with the missile launcher. The fiber optics would also transmit reports on missile and launcher status, and could transmit the order to launch the missile. Since these land-line communications could be easily interrupted and destroyed in a nuclear attack, the MX fields rely on backup radio communication links between the launcher and higher authority. An airborne launch control center (ALCC), always on airborne alert, would serve as a radio relay for two-way communication with higher authority. Other radio links presently designed into the system that do not rely on the ALCC for relay, support one-way communication from higher authority to the missile launcher. All radio signals are picked up by a medium frequency (MF) antenna, buried nearby each shelter.

Since the missile is stored in a horizontal position while in the shelter, the missile launch sequence will involve opening the shelter door, a partial egress of the missile/launcher so the missile portion of the launcher is fully outside the shelter, erection of the missile to a near vertical position by the launcher, and finally ejection of the MX missile from its launch canister by generated vapor pressure and subsequent missile engine ignition (see fig 16)

Figure 16.—Missile Launch Sequence



Closure opened



Launcher emerged and erected to launch position

SOURCE U S Air Force

Along with the above mentioned elements, the Air Force baseline includes two MX operating bases, including housing areas and airfields, three to six area support centers, and other support facilities.

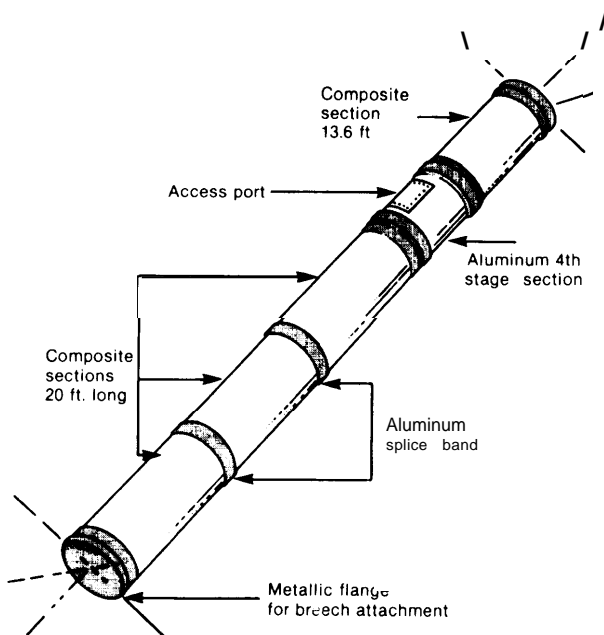
These elements are now discussed in detail. For notational purposes the term "launcher" will refer to the missile-cannister-launcher assembly.

## Missile Cannister and Launcher

The missile cannister is a hardened tubular structure (fig. 17) designed to house the missile horizontally prior to launch, and to provide the impulse, in the form of high pressure steam, to eject the missile from the cannister, a procedure known as cold launching. The missile is supported in the cannister by a series of pads to restrain the missile and reduce loads on it during transport and nuclear attack. The pads are arranged as a set of circumferential rings along the motor casings. The high pressure steam for missile ejection is generated by a water cooled gas generator, producing pressures sufficient to eject the missile from the cannister with an exit velocity of approximately 130 ft/sec.

The launcher assembly (see fig. 15) is made up of several components, and several sections. These parts include a forward section, consisting of a forward shock isolation system to help cushion the missile during nuclear attack, and a set of rollers for transferring the missile to and from the transporter and protective shelter. The middle section of the launcher holds the missile/cannister assembly,

**Figure 17.—Cannister Construction**



SOURCE. U S Air Force

and the aft section contains command, control, and communications gear, emergency batteries, and a second set of rollers for missile transfer. Total weight of the missile-launcher unit is expected to be about 500,000 lb,

Erection of the cannister for launch is achieved by a Sliding block and connecting rod linkage, initiated by a pyrotechnic actuator.

## Protective Shelter

The protective shelter would house and conceal the launcher and would be designed to protect it during nuclear attack. Essentially, it would be a cylinder of reinforced concrete, approximately 170 ft long, and lined with 3/8 inch steel to protect the missile against nuclear electromagnetic pulse effects. It would have a 14.5-ft inner diameter and 21-inch thickness; it would be buried under 5 ft of earth, with an exposed concrete and steel door 10 ft off the ground, as shown in figures 18 and 19. A garage type structure, the shelter would house the launcher horizontally; hence the name, horizontal shelter.

In the present design, allowance is made to have two plugs installed in the roof of each shelter. Removing the plugs would allow selective viewing of the shelter contents by satellite to help assure arms control verifiability.

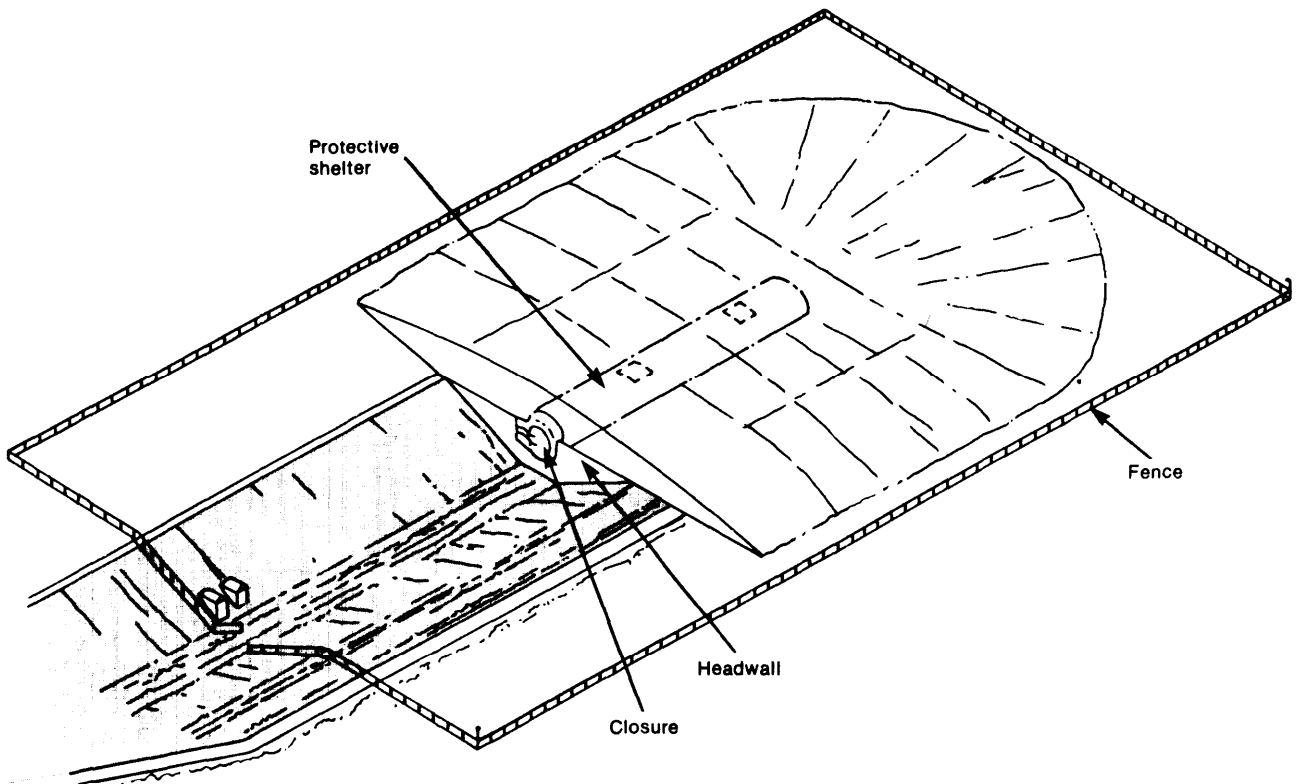
A fence around each shelter would enclose 2.5 acres, an area also guarded by onsite intrusion sensors and remote sensors as part of the physical security system.

The shelter support equipment, including environmental control, AC/DC conversion, and emergency batteries, would be housed outside each shelter, but within the fence.

## Transporter

The transporter would be a manned roadable vehicle that would carry the launcher within a cluster between shelters and the cluster maintenance facility (see fig. 20). It is also designed to transport the mass simulator, and to perform the exchange of launcher with simulator while parked at the protective shelter.

Figure 18.— MX Protective Shelter Site



The transporter would be a heavy vehicle, weighing 1.1 million lb unloaded, and 1.6 million lb when loaded with the launcher or mass simulator. It would be about 200 ft long, 31 ft high, and would require 26 tires. The transporter's cargo bay would be constructed to hold a launcher and mass simulator, or two mass simulators, at the same time for purposes of exchange at a shelter (see fig. 21). This exchange is to be accomplished by providing two sets of rolling surfaces in the transporter, one for the launcher and one for the mass simulator, and an elevator inside the transporter to position the cargo for transport (see fig. 22). Transfer of the cargo at the shelter site would be accomplished by an electrically powered roll transfer.

Like the shelter, the transporter is designed to have two ports on its roof to permit selec-

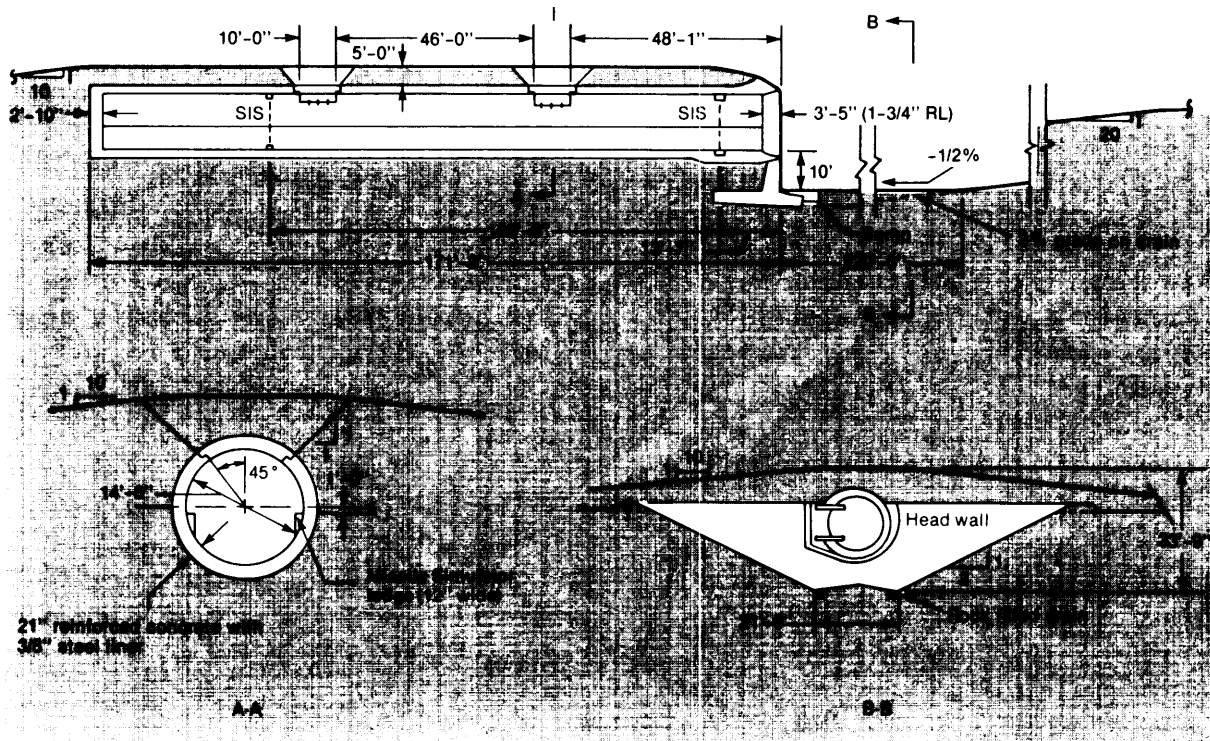
tive viewing of its contents for purposes of arms control verification.

The transporter is designed to protect itself and its contents from the electromagnetic pulse of a high altitude nuclear burst, but it would otherwise be vulnerable to nuclear attack. Power to the transporter would be supplied by 10 drive motors and 2 turbo generators. It would have a 15 mph capability on level road, and would have automatic guidance with manual override. It would be manned during all transport activities.

### Mass Simulator

The MX mass simulator would be an arch-shaped structure made of reinforced concrete (see fig 23). It is designed to match the launcher's weight (500,000 lb), center of gravity loca-

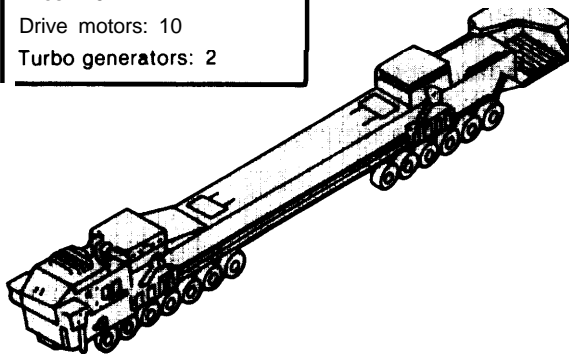
Figure 19.— MX Protective Shelter



SOURCE. U S Air Force

Figure 20.—Transporter

Characteristics
Length: 201 feet
Width: 16 feet (over tires) 25 feet (overall)
Height: 31 ft 6 in.
Weight: 1,600,000 Pounds (loaded)
Tires: 26
Drive motors: 10
Turbo generators: 2

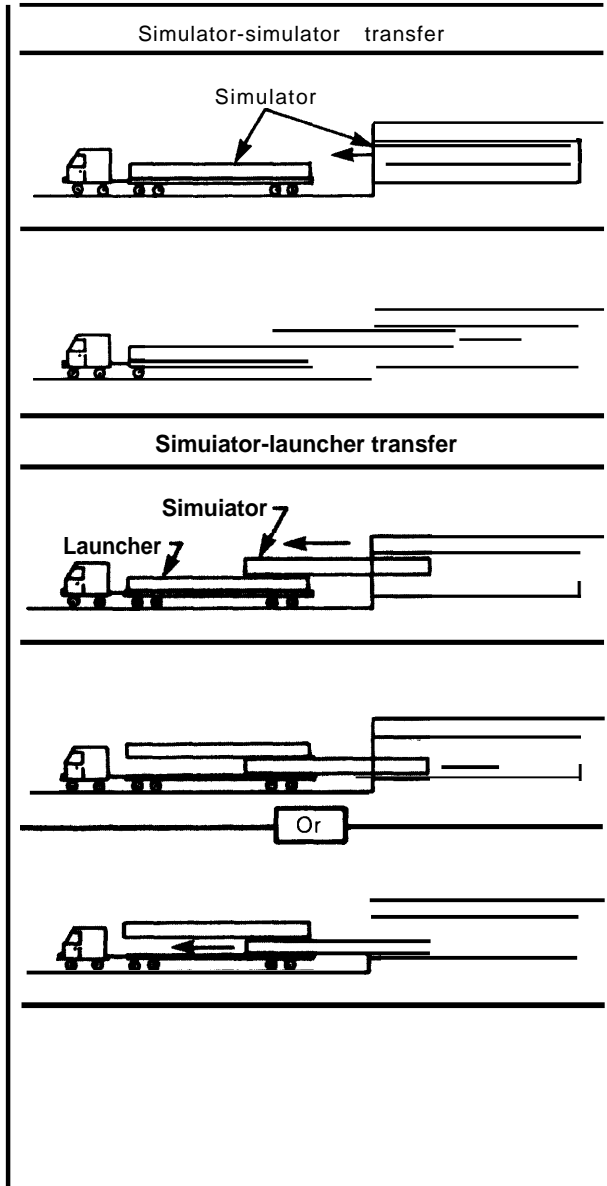


SOURCE U S Air Force

tion, external magnetic characteristics, and other signatures, so that when it occupies a shelter, or when it is carried by the transporter, it could not be distinguished from the missile by an outside observer. Square openings, or notches, are located in the top of the simulator arch, and aligned with the plugs in the shelter roof, so that during arms control verification activity, when all of the shelters are occupied by mass simulators and the shelter plugs are removed, a satellite could see through the openings in the mass simulator, and thereby observe the absence of the launcher in the shelter.

The mass simulator also would be provided with running gear to accomplish its roll transfer into and out of the transporter. There would be a separate, upper ledge in the shelter to support the simulator. For reasons of PLU, the simulator's running gear and its axial location would be the same as the launcher.

Figure 21.— Missile Launcher and Simulator— Transfer Operations

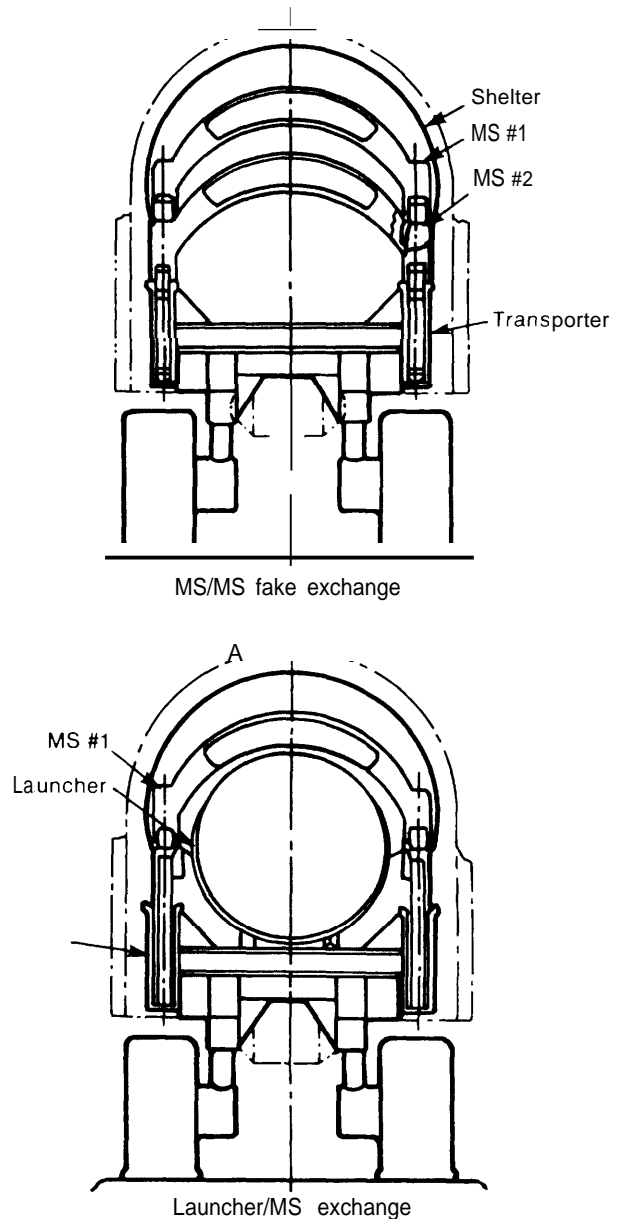


SOURCE U S Air Force

### Cluster Layout

Each cluster would contain 23 shelters, arranged more or less along a linear string, and connected by a cluster road (see fig. 24). Spacing between adjacent shelters would be approximately 5,200 ft, with a minimum spacing of 5,000" ft In addition to the 23 shelters,

Figure 22.— Mass Simulator (MS) and Launcher Exchanges

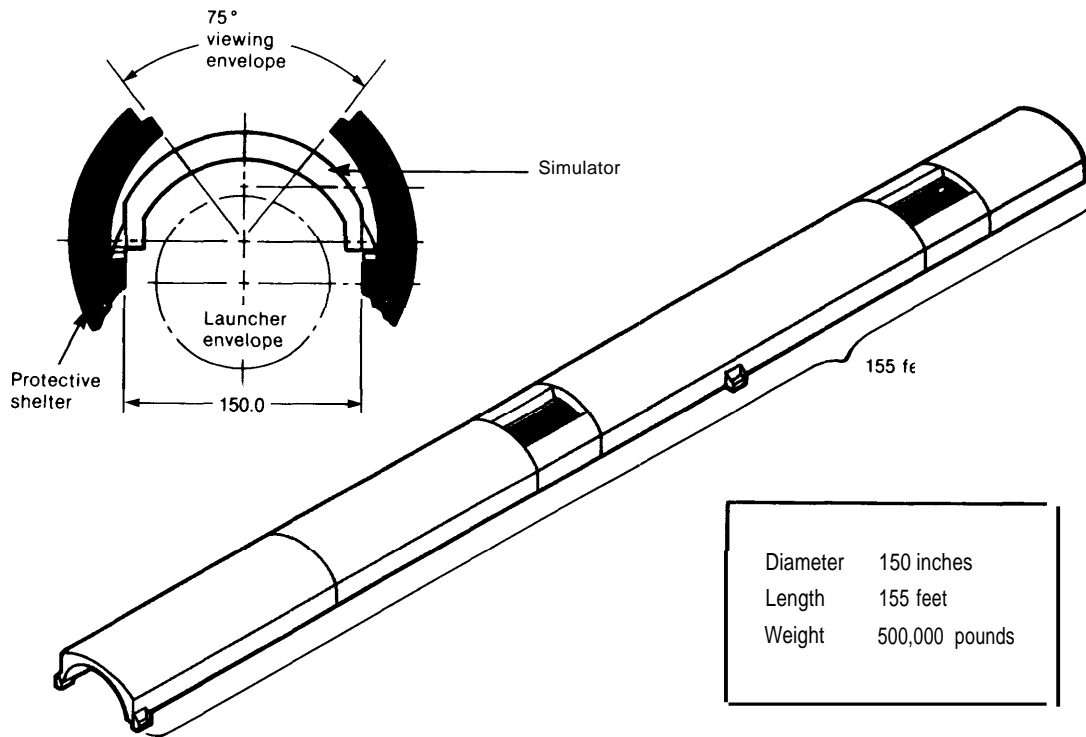


SOURCE U S Air Force

each cluster would contain a cluster maintenance facility (CM F), where minor repair-s on the launcher could be accomplished, and that could house the transporter when not in use, Most of the time the cluster would be unmanned, except for maintenance activities, SALT verification, and security patrols

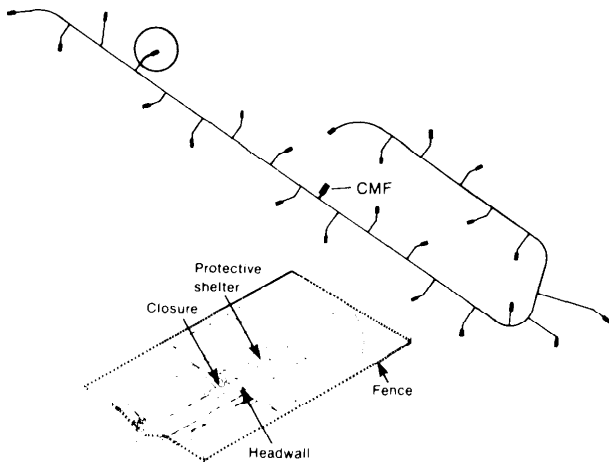


Figure 23.—Mass Simulator



SOURCE U S Air Force

Figure 24.—Cluster Layout



SOURCE U S Air Force

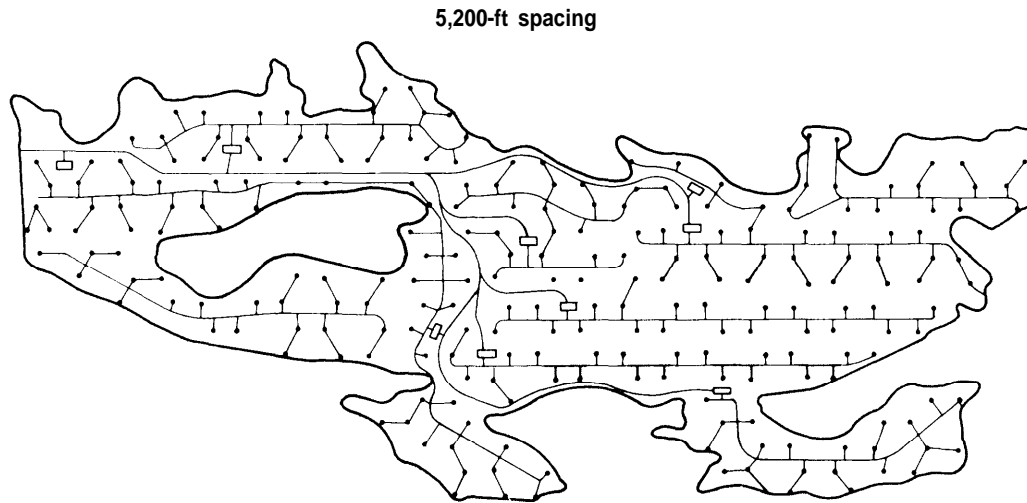
Within each valley, the shelters would be arranged in a close-packed hexagonal pattern (see fig. 25). The lattice is not completely filled, having approximately one-third fewer shelters than the spacing actually allows. The

reason for this design is that the confluence of the shock fronts from the nuclear detonations at the vertices of the hexagon could be sufficient to destroy a missile placed in a shelter at the center of the hexagon. Consequently, this center shelter has been left out. In the event of a Soviet effort to increase their number of missile RVS, it is presently contemplated that these "gaps" in the hexagonal layout will be "backfilled" with additional shelters. If the Soviets fractionate their warheads, thus decreasing the individual warhead yields sufficiently, backfilling could be feasible.

### Command, Control, and Communications (C<sup>3</sup>)

The C<sup>3</sup> system (see fig. 26) is divided into two categories: peacetime and wartime. The peacetime/preattack C<sup>3</sup> system would consist of a centralized command control located in the operational control center (OCC), at the base, and a communications network spanned by an extensive underground grid of fiber optic

Figure 25.—Shelter and Road Layout



SOURCE U S Air Force

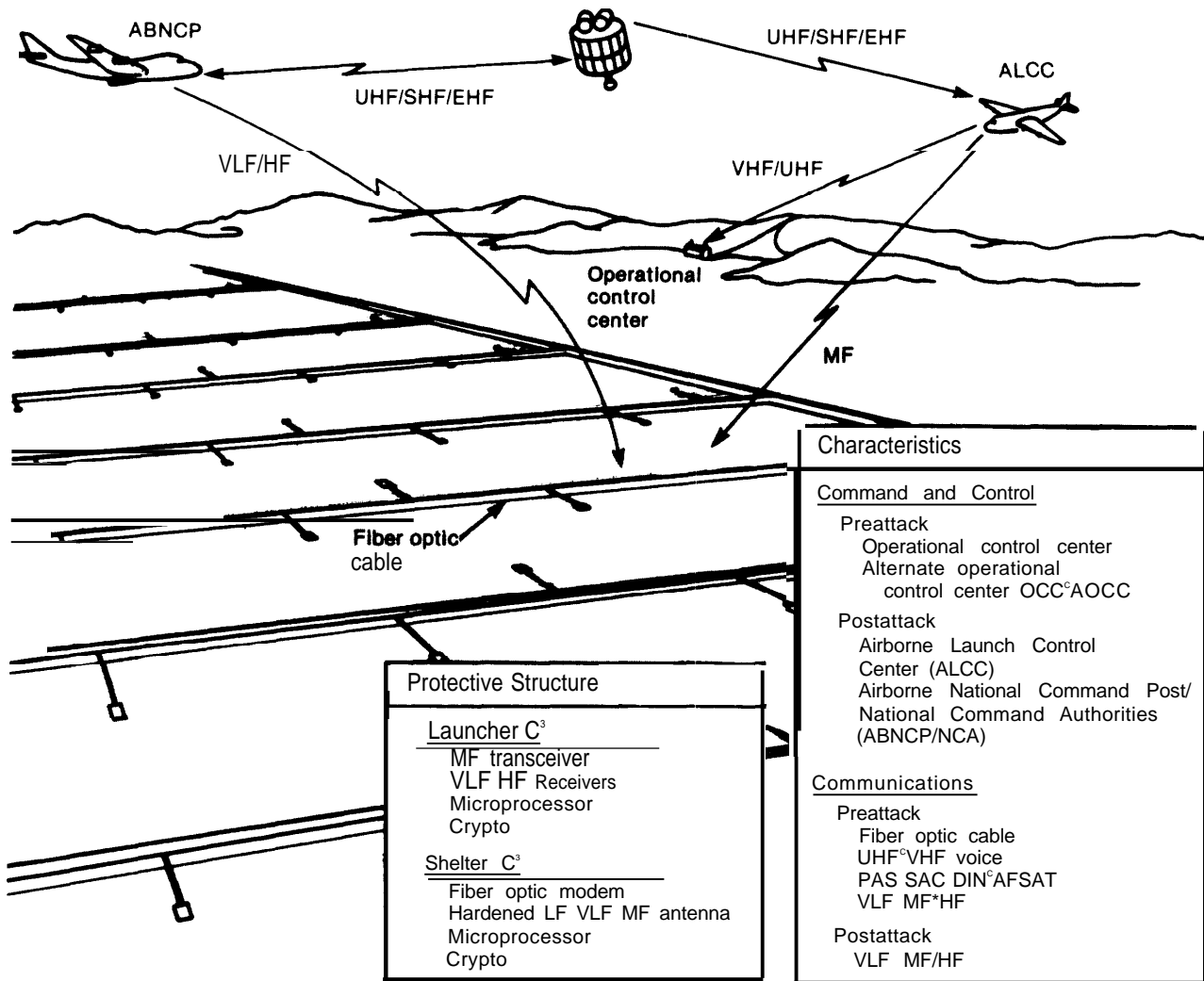
cable between the OCC and all of the missile launchers. The OCC would be in continuous two-way communication with higher authorities, including the airborne national command posts (Looking Glass, NEACP, etc.) and the National Military Command System (NMCS). The fiber optic cable system would have a high data rate (48 kilobits/sec) with a relatively long attenuation length. Because fiber optic cable is a dielectric, it is resistant to electromagnetic pulse (EMP) effects. By making the cable sufficiently thick, a protective metal sheath might not be required to protect it against gophers, gerbils, and the like. Each line contains three fibers (one for communication in each direction and one spare). PLU would be maintained by uniform formatting and message protocols for missiles and simulators. The entire system would require about 11,000 miles of cable.

The peacetime C<sup>3</sup> system is not intended to survive a nuclear attack, since the operational control center would be a primary target, and fiber cable connectivity would be interrupted by cratering. The postattack C<sup>3</sup> system would take over at this point. The postattack system would consist of an airborne launch control

center (ALCC), that would have two-way communication with the missile force via MF (medium frequency) radio. The ALCC's plane would always be airborne, with a backup ALCC on strip alert. Each shelter would have buried beside it a 600 ft crossed MF dipole antenna, that would serve as a receiving and transmitting antenna. The transmitting power at the shelter is 2 kW, and with a soil propagation loss of -30 db, would transmit 2 watts effective radiative power. MF was chosen, in part to combine the advantage of high frequency data rates with low frequency propagation through ionized, nuclear environments. In addition, MF does not propagate through (or, at least, is greatly distorted by) the ionosphere, making reception intentionally difficult by satellite. In the present design, MF would be the only means by which the missiles could "talk" to command authority. Therefore, when the ALCC would no longer be operational, the launcher would not be able to report back to higher authority.

In addition to two-way MF radio, the baseline is designed to have one-way radio communication from higher authority directly to

Figure 26.—Command, Control, and Communications System



SOURCE U S Air Force

the launcher via high frequency (HF) and very low frequency (VLF) when the ALCC is no longer airborne (in-flight endurance of the ALCC is about 14 hours). Two-way communication between higher authority and the launcher via HF is presently contemplated, so that the launcher can give status and report back when the ALCC is not operational. We should point out that even if two-way HF were installed it would not necessarily assure continuous, long-haul communication. Because the ionosphere would be disturbed for a period of hours after the initial attack before slowly recovering, long-haul HF via ionospheric skywave cannot

always be depended on (Adaptive HI techniques would not solve the interruption of transmission, although it could recover more quickly than conventional HF). HF antennas would probably have to be added to the system. In addition to the buried MF antennas, since using the same MF antenna for HF transmission would incur a variety of technical problems,

To help assure receipt of the launch command by all of the launchers from the ALCC, the launcher that first received the message would rebroadcast the same message by MF

groundwave to the other launchers. They, in turn, would receive and rebroadcast again, and so on, until all of the surviving launchers received the message. This simulcast transmission has been tested and verified in the field for completeness of coverage. As part of this process, preselected missile targets would be reallocated and reoptimized among the surviving missiles by an algorithm processed by one of the launchers.

### Power Supply System

Power to operate the entire MX/MPS system (see fig. 27) is planned in the baseline system to come from local utility companies. Power would be received at two or more switching stations at 230 kV, 60 Hz. Area substations then receive this power at 138 kV and step it down to distribution centers at 24.9 kV. Power from the distribution centers to the shelters is conveyed underground, at 14.4 kV and is converted to DC before entering the shelter. Power consumption at all shelters would be approximately 15 kW, with simulator-occupied shelters consuming the same power as missile occupied shelters. As a backup to commercial power, each distribution center contains standby diesel generators to supply primary power when normal power fails. The diesel engines are designed to start automatically.

If commercial and backup diesel power are unavailable, emergency power would be supplied by battery on site at the shelter for shelter operations, and on the launcher for launcher and missile operations.

Survival power for the missiles after an attack would be provided by survival batteries (LiS6Cl<sub>2</sub>) to critical launcher and missile needs only. Survival time is classified and is included in the classified annex.

### Launch Procedure

Launch of the MX missile is accomplished in the following automated sequence (see fig. 28):

- 1 The launch message is transmitted to the missile launcher by radio communication from the Strategic Air Command (SAC), ALCC, or from the MX operating base via fiber optic land lines, if the attack has not yet destroyed them.
- 2 The launcher shock isolation masts are retracted and egress rollers are deployed.
- 3 The shelter door is unlocked and opened.
- 4 The launcher egresses from the shelter, by its own battery power, exposing the canisterized missile.
- 5 The launcher erects the missile to near vertical (85° to 90°)

Figure 27.—Electrical Power Distribution

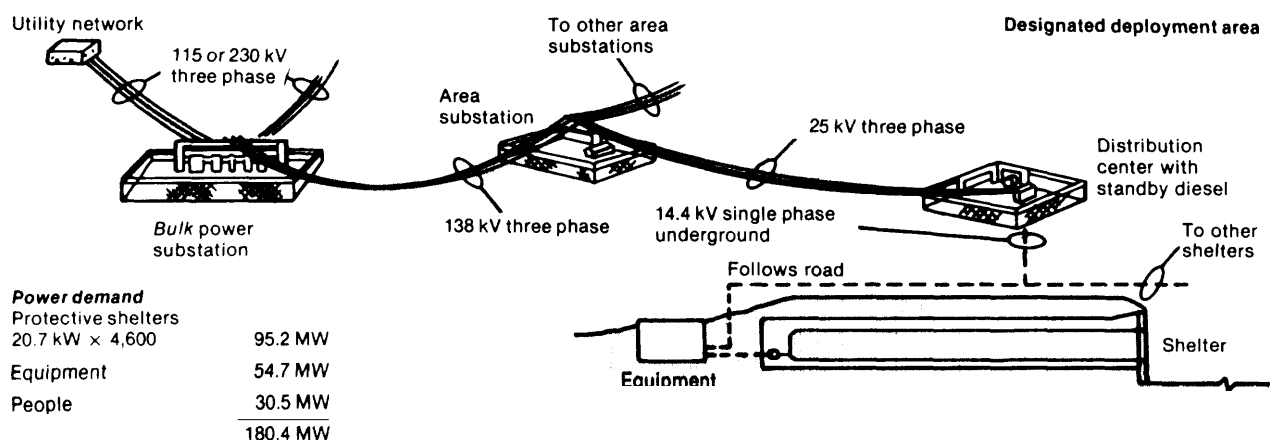
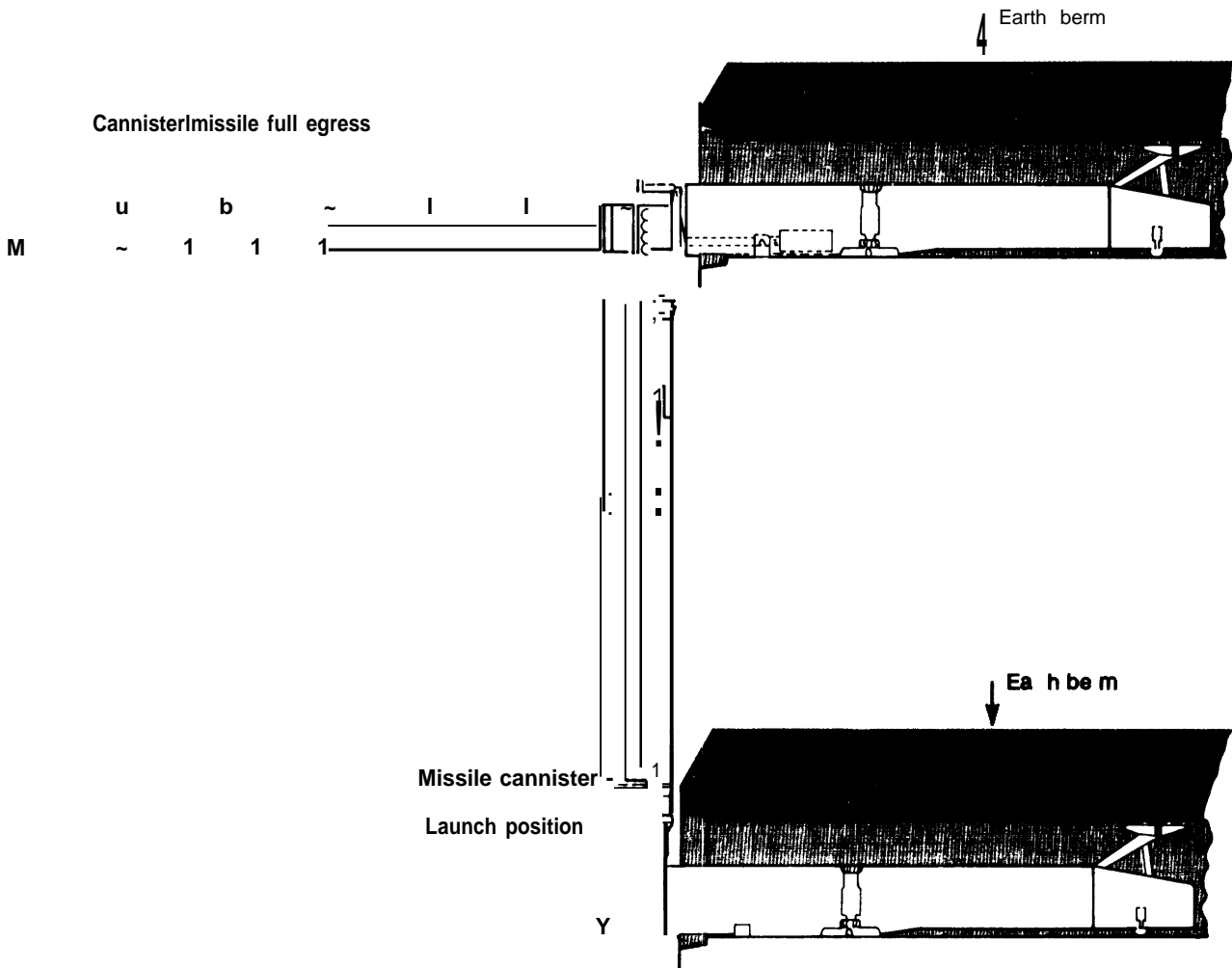


Figure 28.—MX.CannisterMi ssile Launch Sequence



SOURCE U S Air Force

6. The missile is expelled from the cannister by the hot gas steam generator, at an exit velocity of about 130 ft/sec.
7. The missile's stage 1 fires,

The entire missile launch sequence is designed to require several minutes.

### Missile Mobility

In the baseline system, the transporters are intended primarily to move missiles between the cluster maintenance facilities and shelters for the purposes of maintenance, supporting arms control verification, and PLU. The trans-

porters could also be used for relocation of missiies among cluster shelters (but not between clusters). Because there are 200 transporters and 200 missiles, it would be possible to move al l of the missiles at the same time, although this is considered very unlikely because it would leave all of the force outside the /protective shelters and exposed to a pre-emptive attack.

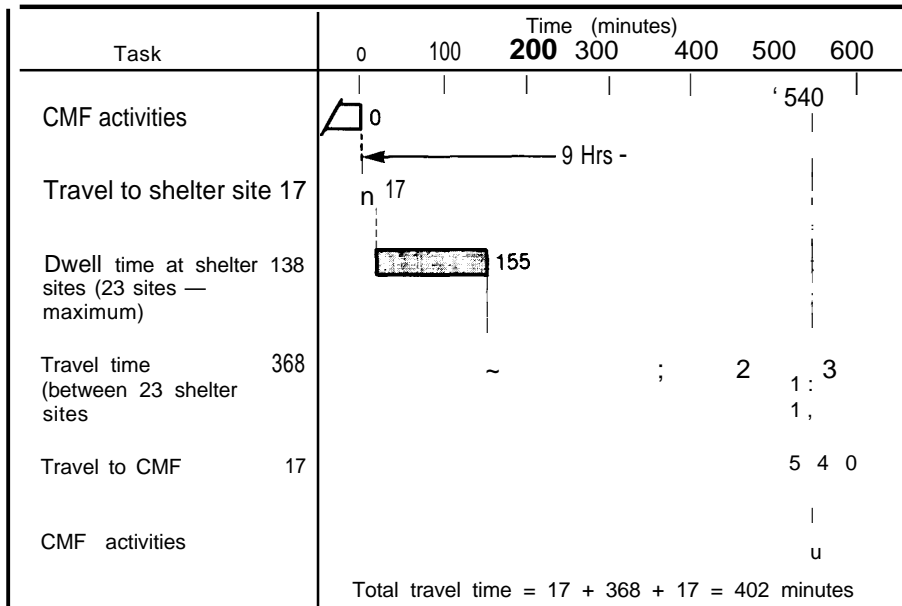
Another possibility would be to keep a fraction of the missi le force on transporters, on the road. When the warning of an attack came, the on-road missile force would "dash" into the nearest shelters.

There is some advantage to these mobility options, but there are limitations as well. If a partial or complete breakdown of PLU is suspected, then any number of missiles can be relocated in new shelters. This relocation would be performed by a visit of the missile transporter to each shelter, where it would either simulate or perform an authentic missile pickup or deposit. The time it would take to perform this operation for the entire missile force has been estimated to be about 9 to 12 hours, after which time the missile could be in a different position so that previous location information possessed by the enemy would be invalid. Figure 29 shows the timeline for this "rapid" relocation. A decision to relocate all of the missiles at the same time would be unlikely, in view of the earlier discussion. Depending on how PLU was broken, this relocation might or might not reestablish the location uncertainty. If PLU had been broken by long-term efforts at data collection or espionage or both, then rapid relocation could reestablish PLU. If, on the other hand, the enemy could locate the missiles through technical or other means in a short time, then no amount of relocation would reestablish PLU.

The second mobility option, the "dash" or hide-on-warning option, would place a portion of the missile force on the road, in motion or parked near a shelter. Upon warning of attack, the manned transporter would dash to the nearest shelter, deposit the launcher, and back off from the shelter so that the missile could egress and launch. The time estimate for this operation is slightly under 6 minutes, which would be required to respond to warning of a submarine launched ballistic missile (SLBM) attack, and secure the missile in the shelter before the attacking warheads arrive.

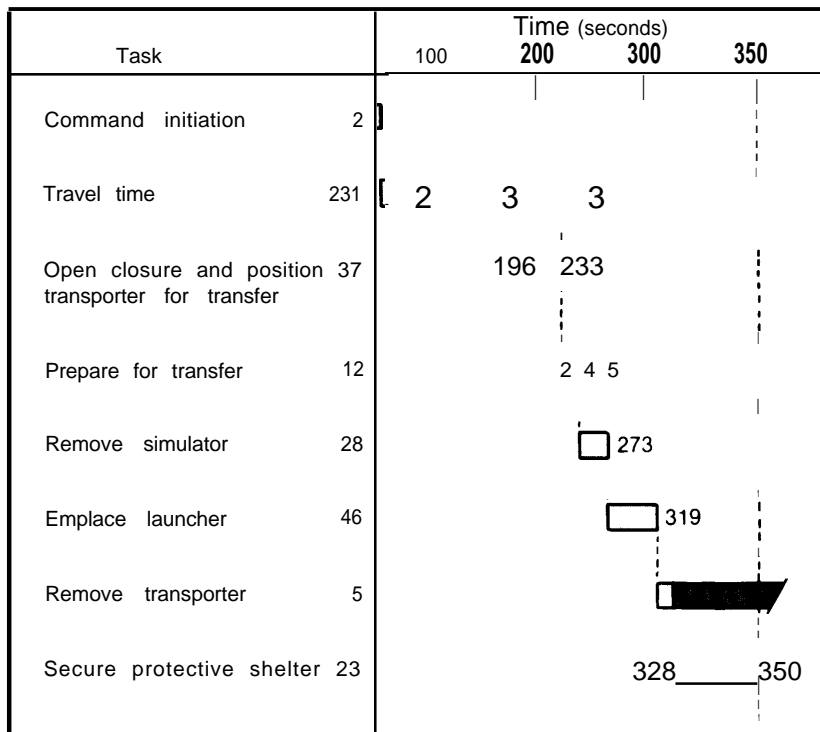
The dash timeline for this operation is displayed in figure 30. Since the transporter is not designed to withstand an SLBM attack, it cannot be used after the attack. The advantage of this option is that it acts as a hedge against a complete breakdown of PLU, so that at least a fraction of the missile force might survive the initial attack. This option assumes that the attacker does not know the location of the missile at the time of the attack. This may or may not be true, since it depends on the ability of his reconnaissance to observe transporter location, and use this information to

Figure 29.—Transporter Rapid Relocation Timeline



SOURCE U S Air Force

Figure 30.—Dash Timeline



SOURCE U S Air Force

target the shelter into which the missile would seek cover. Without commenting on the present Soviet capabilities to accomplish this task, it might not be wise for the United States to rely on dash as a substitute for PLU. The job of real-time reconnaissance and retargeting of shelters in order to defeat the dash option is not technically infeasible, although it may be high-risk in the near future. Thus, reliance on dash may be a useful hedge against a loss of PLU in the near term, but its long-term prospects are more uncertain.

Secondly, after a first attack, reconnaissance would be able to locate the transporter. Since the transporter would be located next to the occupied shelter, the attacker would know the location of the dashed missile, and could attack it on the next wave or by bomber force if the MX missile were not launched in the time remaining.

Finally, since dash relies on warning of attack, it would have a common failure mode with the bomber force, again underscoring the

importance of maintaining a PLU-perfect system, rather than relying on missile mobility as a hedge.

### SALT Monitoring Operations

The basic need to verify missile numbers for an MPS deployment, without compromising missile location uncertainty, is satisfied by allowing the means to count missile *numbers* *Without determining specific missile location*. This capability is being designed into the system, by following a slow, open, and observable missile and launcher assembly process in the assembly area. This process would allow national technical means to observe each missile constructed in the assembly area, before it is deployed in a shelter cluster. Second, there is a unique paved connecting road between the assembly area and the deployment area, and a special transporter vehicle to move the missile and launcher to the deployment area. Third, the missiles and launchers would be confined in clusters, with cluster barriers that would

make removal and replacement of launchers and missiles observable by satellite.

To further facilitate SALT monitoring of the missile force by national technical means (NTM), plugs in the roof of each shelter have been designed as part of the system. The monitoring process would proceed as follows:

- The transporter deceptively relocates the missile from the shelter to the cluster maintenance facility, leaving a mass simulator in each shelter of the cluster.
2. Special vehicles would clear the 5-ft overburden on top of the shelter, and the two SALT concrete ports would be removed from the top of the shelter, exposing the contents of the shelter to satellite reconnaissance.
3. The shelters would be left in this configuration for 2 days to accommodate NTM viewing,
4. The SALT ports would be replaced, the overburden restored, and the missile returned to one of the shelters. The estimated timeline for this process is illustrated in table 4.

### Siting Criteria

There are three fundamental siting criteria that apply to any MPS site selection process:

- first, large areas of relatively flat land are necessary to permit clusters of shelters and to allow transport of the missiles among shelters;
- second, for the purpose of minimizing construction costs, it is desirable to have

- third, for the purpose of minimizing the number of people displaced or otherwise impacted by construction and to minimize threats to PLU from public activities, it is desirable to have a low-population density area,

The siting criteria indicated in table 5 reflect these principal considerations:

On the basis of these screening criteria, the Air Force identified 83,000 mi<sup>2</sup> of geotechnically suitable lands throughout the Western United States and defined six candidate areas for "militarily logical deployment" that were

**Table 5.—Principal Exclusion/Avoidance Criteria Used During Screening**

Category	Criteria definition
Geotechnical	Surface rock and rock within 50 ft. Surface water and ground water within 50 ft.
Cultural and environmental	Federal and State forests, parks, monuments, and recreational areas. Federal and State wildlife refuges, grasslands, ranges, and preserves. Indian Reservations. High potential economic resource areas, including oil and gas fields, strippable coal, oil shale and uranium deposits, and known geothermal resource areas. Industrial complexes such as active mining areas, tank farms, and pipeline complexes. 20 mi. exclusion radius of cities having populations of 25,000 or more. 3.5 mi. exclusion radius of cities having populations between 5,000 and 25,000. 1 mi. exclusion radius of cities having populations less than 5,000.
Topographic	Areas having surface gradients exceeding 10% as determined from maps at scale 1:250,000. Areas having drainage densities averaging at least two 10 ft. deep drainages measured parallel to contours, as determined from maps at scale of 1:24,000.

**Table 4.—Monitoring Timeline**

Remove missile	1 day (12 working hours)
Remove SALT ports	1 day (12 working hours)
NTM inspection	2 days
SALT port replacement	2 days
Replace missile	1 day (12 working hours)
Total	7 days

SOURCE U S Air Force

SOURCE. U.S. Air Force



subsequently evaluated on the basis of distances from coasts (to reduce the potential effectiveness of sea-based forces), distances from national borders (to reduce vulnerability to "unforeseen threats")\* as well as compatibility with local activities and the sense of

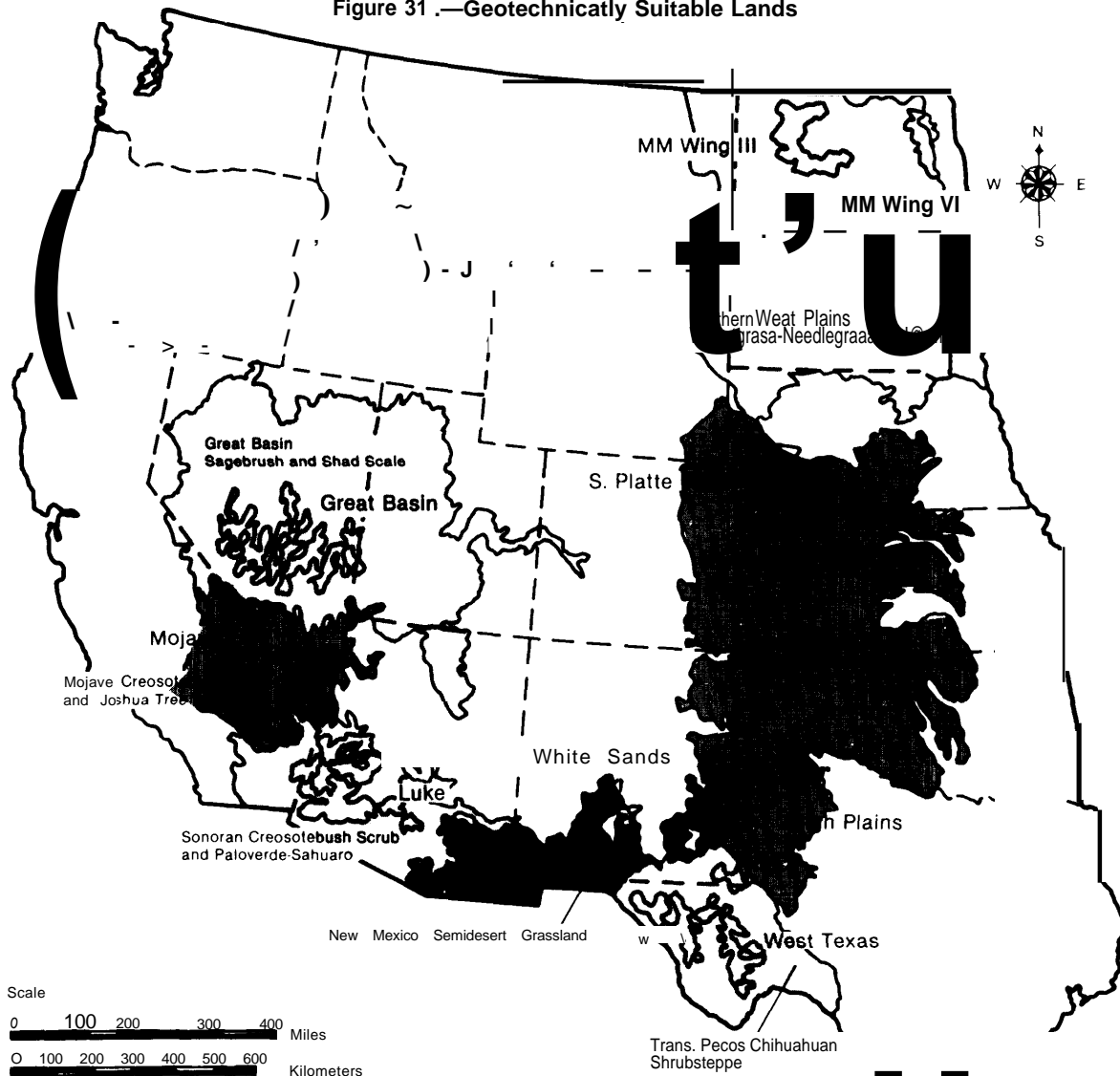
\*In contrast to the other primary siting criteria, OTA's assessment does not indicate that a measurable degree of security derives from locating MPS at least 200 miles from national borders, nor that Mexico and Canada pose significant "unforeseen threats" to MPS security

Congress that the basing mode for the MX missile should be restricted to location on the least productive land available that is suitable for such purpose. "

Figure 31 indicates the areas of geotechnically suitable lands identified by the Air Force.

Of these areas, the Great Basin of Nevada and Utah and the Southern High Plains of west

Figure 31 .—Geotechnically Suitable Lands



SOURCE U S Air Force

Texas and New Mexico were identified as the only “reasonable risk” areas, and the Nevada/Utah location was selected by the Air Force as the preferred area for MX/MPS.

Table 6 indicates the “candidate areas” identified by the Air Force along with the predominant vegetative characteristics of the region.

### Roads

The MPS will have a substantial road network of approximately 8,000 miles.

The designated transportation network (DTN), consisting of paved asphalt roads, 24-ft wide with 5-ft shoulders, will connect the assembly area with each cluster, and will total between 1,300 and 1,500 miles. Inside each cluster will be roads connecting all the shelters and the cluster maintenance facility. About 6,200 miles of these cluster roads will be constructed, 21-ft wide with 5-ft shoulders. These roads will be unpaved and treated with dust suppressant, and are designed to support the missile transporter. Large earth berms will prevent movement of the transporter between the DTN and the cluster roads. In addition, some 1,300 miles of smaller support roads in the cluster area will be built to connect shelter clusters and support SALT-related activities, Figure 32 illustrates the construction profiles of the different roads.

### Physical Security System

The Air Force has examined two basic systems for MPS security: area security, involving restricted access and continuous surveillance of the cluster areas; and point security, involving restricted access only to the missile shelters, command facilities, and other military facilities. Figures 33 and 34 compare the configurations of point and area security systems.

Under area security, each cluster of shelters would be bordered by a warning fence and posted notices. Only authorized personnel would be permitted in the posted area, and their movements would be continuously monitored by remote surveillance. Security forces would be available at all times for dispatch to unauthorized intrusions. To prevent the implantation and operation of sensors from aircraft, the airspace over the deployment area would also be restricted to an altitude of 5,000 ft, and controlled to an altitude of 18,000 ft (i.e., a permit would be required).

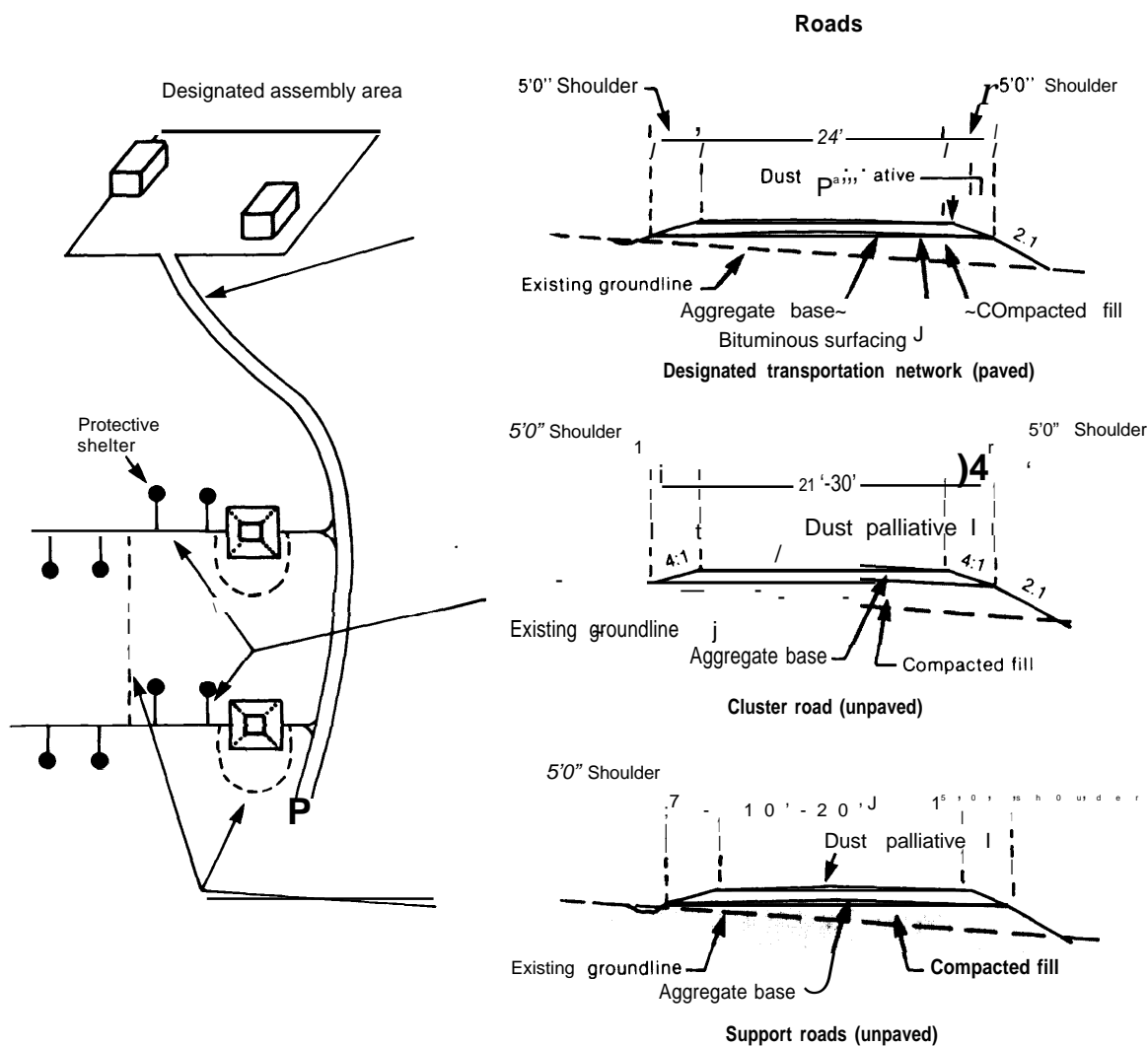
Under the point security system, each missile shelter would be surrounded by a fenced area of 2.5 acres, and only those 2.5-acre sites and necessary military facilities would be excluded from public access. Although the cluster roads would be separated from the paved DTN roads by earth berms to prevent movement of the missile transporters, the berms

**Table 6.—Candidate Areas**

Area	State	Ecosystem	Population		Private land ownership
			Urban	Rural	
Great Basin	NV/UT	Desert shrub/sagebrush/range	4,922	1,215	<10%
Mojave Desert	CA	Desert shrub/range	51,811	21,980	< 10%
Sonoran Desert	AZ	Desert shrub	77,670	13,183	10%
Highlands	AZ/NM/TX	Semidesert grassland/desert shrub	57,361	9,449	>50%
Southern High Plains	TX/NM	Plains/rangeland	83,921	15,504	95/0
Central High Plains	CO/KA/NE	Mixed grass prairie	54,479	15,123	>95/0
Northern Great Plains	MT/ND	Mixed grass prairie	Unavailable	Unavailable	Unavailable

SOURCE U.S. Air Force

Figure 32.— Road Construction Profiles



would be otherwise passable and the public would have nominally unrestricted access to all unfenced portions of the deployment area.

To accomplish this task, the physical security system would include the following safeguards and activities in the deployment area:

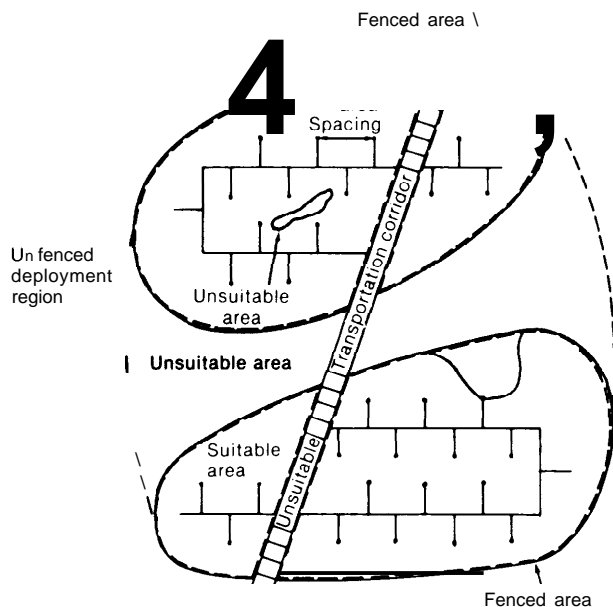
- intrusion sensors and access monitors at the (unmanned) shelter sites and cluster maintenance facilities,
- a large number (2,300) of small radars for cluster surveillance,

- four area support centers that would house helicopters for 30-minute response time to cluster-area sensor alarms, and
- roving ground patrols of 20 two-man teams.

Because there would be unrestricted ground movement, there would also be no restrictions on airspace.

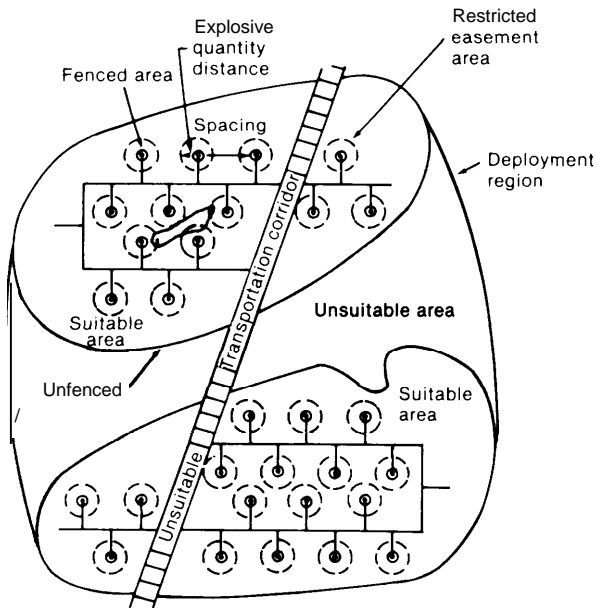
The manning estimate for security police, that includes deployment area patrols, area support center, helicopter crews, and base per-

Figure 33.— Area Security



SOURCE U S Air Force

Figure 34.— Point Security



SOURCE U S Air Force

sonnel is about 2,300, or about 25 percent of the entire manning estimate. This percentage is similar to that at the Minuteman wings.

At the same time, unrestricted public access to the deployment area would require increased security measures to counter against portable or emplaced sensors. Attempts would be made by the security force to deter persons who might be involved in planting sensors for missile detection, attempting to penetrate the sites, or sequentially visiting a number of shelters. Such measures also might include escorts accompanying all transporter movements, and would, presumably, include frequent "security sweeps" to detect implanted sensors.

Furthermore, it is likely that additional controls would have to be exercised on activities within the deployment area. The Air Force has stated that restrictions on public use of the deployment area would not be necessary, and that ranching and mining activities could proceed "up to the fences." However, mineral exploration and mining activities pose problems for PLU security. For example, modern geological exploration and development utilize sophisticated electronic equipment, and test for the same types of chemical, electrical, and magnetic signatures as would be associated with the MX missile. In the event that potentially detectable differences exist between MX missiles and the decoys, unrestricted uses of geologic testing equipment would pose security threats,

Increased traffic due to the necessity of security sweeps to protect against the covert implantation of sensors in the areas surrounding roads and shelters would, however, substantially increase impacts on the physical environment.

President Carter decided against the use of an area security system and directed the Air Force to proceed with point security in 1979. The Air Force presently believes that area security would be infeasible and unnecessary. Nonetheless, OTA'S assessment of the tech-

nical problems associated with PLU suggests several implications for the security system requirements of MPS. First of all, it is possible, as the Air Force maintains, that engineering solutions to the problems of missile and decoy similitude will permit point security as planned. Alternately, as has been noted, it is possible that problems of PLU technology will make MPS vulnerable to detection regardless of security measures. Thirdly, it is possible that weaknesses in PLU technology could be offset by an area security system. Finally, it is possible that uncertainties in PLU technology would warrant operational restrictions on public activities within the deployment area, but outside the fenced exclusion areas established for point security. If Federal lands are used, this possibility raises questions regarding public access to public lands. For example, mineral explorations that utilize highly sophisticated techniques and equipment for the measurement of magnetic, gravitational, geochemical, and seismological characteristics could pose threats to PLU security if they involved the systematic coverage of areas containing many shelters. Livestock operations could be affected by routine PLU activities (such as security sweeps during calving season); and any interference with livestock operations or mineral activities could lead to litigation claims.

### Land Use Requirements

The land use requirements of MPS basing would depend largely on the type of PLU security system adopted; but the land use impacts and implications would be defined as much by the configuration of the clusters as by the type of security system.

The total land area required for missile shelters, maintenance areas, support facilities, and operating bases, would consist of 33 mi<sup>2</sup>: 19 mi<sup>2</sup> for missile shelters and maintenance areas (4,600 missile sites and 200 maintenance areas) and 14 mi<sup>2</sup> for the operating bases.\* In

\*The Air Force has generally referred to this area as 25 nautical mi<sup>2</sup>, rather than as 33 statute mi<sup>2</sup>. Except where otherwise noted, all figures used in this report, however, refer to statute miles.

addition to this land, however, 60 mi<sup>2</sup> of land would be required for support facilities and 122 mi<sup>2</sup> would be necessary for roads. The total land area defined by the perimeter of the individual clusters would be approximately 8,000 mi<sup>2</sup>, and the total deployment area would be in the range of 12,000 to 15,000 mi<sup>2</sup>.

Figure 35 illustrates the relation of individual clusters to the basing area.

Under a point security system, only the 19 mi<sup>2</sup> of missile shelters, maintenance facilities, and operating bases would be fenced and excluded from public access. Otherwise, it is Air Force policy:

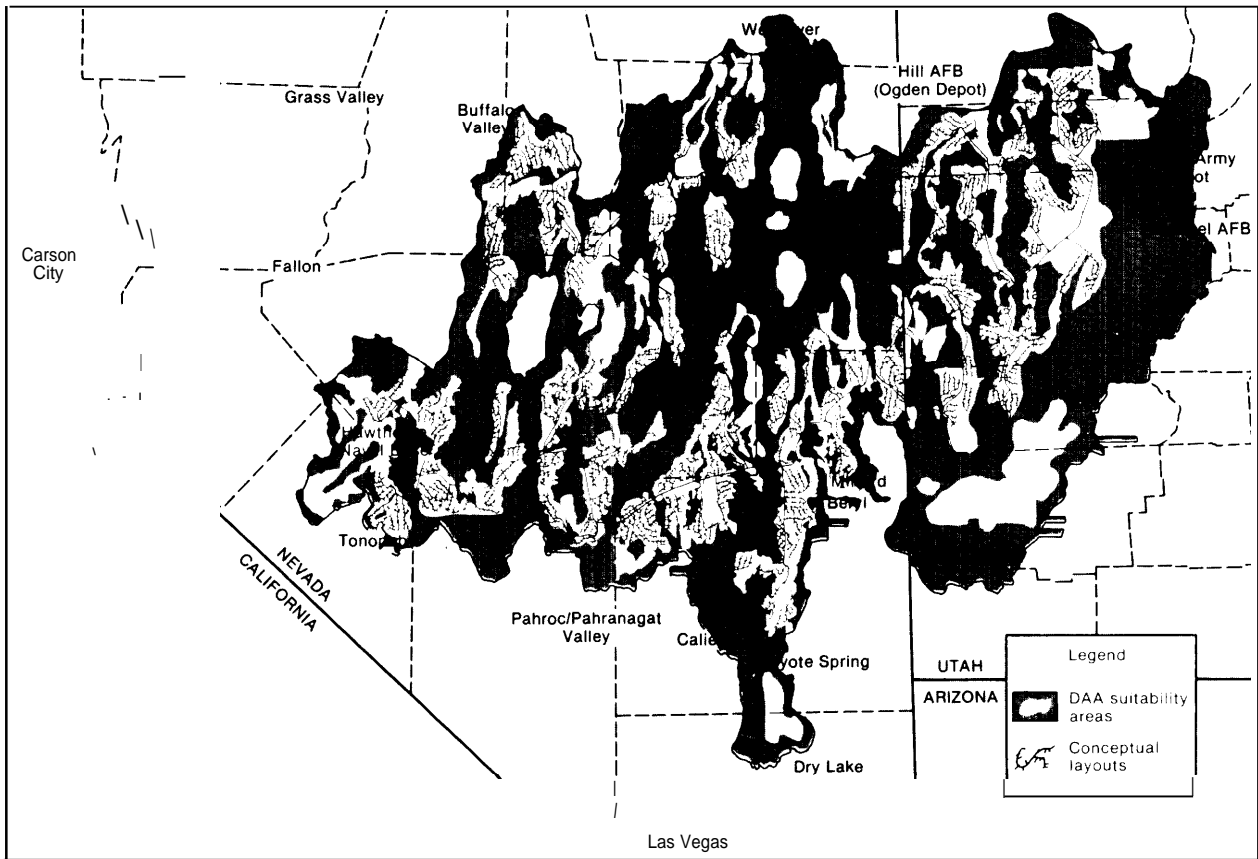
to guarantee civilian access to all but the fenced portions of the MX deployment area. This means that civilians will have essentially the same access privileges to the deployment area that they have always had. Agriculture can take place right up to the shelter fences, and camping, hunting, and mining can continue without hindrance by the Air Force.

A potential conflict with this policy exists to the extent that Department of Defense safety regulations would require a safety zone of approximately 1 mi<sup>2</sup> around each missile shelter; but this regulation would only limit the construction of habitable structures within the safety zone, and waivers could be sought for temporary structures necessary for mining or geologic exploration.

Thus, the total land requirement for MPS would involve an area of 12,000 to 15,000 mi<sup>2</sup> for the baseline system, of which 8,000 mi<sup>2</sup> or more would be restricted from public access under an area security system, and less than 35 mi<sup>2</sup> would be restricted from public access under the proposed point security system. In either event, however, approximately 200 mi<sup>2</sup> of land would be converted from existing range to missile sites, roads, and operating bases.

<sup>1</sup>Unclassified paragraph within *Classified Annex to MX Basing Area Analysis Report*; prepared by HQ USAF/RD-M, Dec 24, 1980.

Figure 35.— Hypothetical MPS Clusters in Candidate Area



SOURCE U S Air Force

In the proposed deployment area of Nevada and Utah, virtually all of the lands involved would be federally owned land under the jurisdiction of the Bureau of Land Management of the Department of the Interior (BLM) and use of the lands for MPS would require congressional action pursuant to the Engle Act (requiring congressional review of land withdrawals in excess of 5,000 acres for military purposes). Additionally, pursuant to the Federal Land Policy and Management Act, the Secretary of the Interior would have to approve permits for rights-of-way or withdrawals for roads, railways, pipelines, powerlines, and other construction-related activities.

In the event that non-Federal lands might be used, it would be necessary to acquire these

lands through lease, purchase, easement, or condemnation. In either case, however, provisions would have to be made for the initial withdrawal of lands substantially in excess of the minimum requirements, to allow site-specific engineering studies and flexibility in final siting determinations for shelters, roads, and permanent facilities.

In its simplest form the implications of these land use requirements are twofold. First, the necessary withdrawal of lands, whether temporary or in perpetuity, and whether of private lands or public lands, will require the negotiated settlement of a wide variety of property claims and constitutionally protected rights. In the proposed basing area of Nevada and Utah, these claims would include patented mining

claims (that are defined as legal property rights), oil and gas leases, BLM grazing permits, water rights, and Native American land rights; all of which are potentially litigious matters.

#### BLM Grazing Permits

In the case of BLM grazing permits, for example, BLM has authority for the integrated management of Federal range resources under the Taylor Grazing Act of 1934. The carrying capacity of the lands is defined in terms of animal unit months (AUMS, or the amount of forage needed for the complete sustenance of a single cow or horse or five sheep or goats for a single month). Allotted grazing rights are determined on the basis of the relative carrying capacities of private and public lands. Thus, the market value of private lands is tied to allotments for Federal land grazing permits, that are in turn defined by the carrying capacity of the land. The Air Force has estimated that MPS would affect less than 1 percent of the allotted AUMS in the proposed deployment area by dividing the total deployment land area (20,000 mi<sup>2</sup>, by the amount of area removed from use (200 mi<sup>2</sup>). In fact, however, the lands removed from use would be drawn largely from the prime grazing lands between the bottomlands and benchlands of the valleys. Even if it were to be assumed that there would be no impacts on the range land beyond those 200 mi<sup>2</sup> directly removed from use, it is clear that the effects on livestock operations would be disproportionately great, and the value of private ranchlands would be diminished as a result. Similarly, these claims would be complicated by any effects of MPS development on the water rights that are integrally related to the carrying capacities of both the public and private lands.

#### Oil and Gas Leases

Although legally distinct, both oil and gas leases, and hardrock mining claims, pose similar institutional problems. Under the Mineral Leasing Act of 1920, Federal lands were made available for oil and gas exploration and development. Significant oil and gas

leasing occurs in the proposed deployment area and estimates of the potential reserves within the overthrust Belt that cuts through many of the canal irate areas suggest the potential for greatly expanded exploration and development within the next decade. The Air Force policy clearly is intended to permit virtually unimpaired oil and gas exploration; but constraints on activities resulting from PLU restrictions could result in litigable claims.

#### Hardrock Mining Claims

Similar, MPS security requirements could result in litigable claims based on hard rock mining activities. Unlike oil and gas activities on the Federal lands, that are leased rights, hardrock mining claims under the 1872 Mining Act are patent claims; i.e., legal title of the public lands are transferred by Government deed into private ownership. As such, patented mining claims create private property interests that are compensable, and to the extent that conflicts arise with MPS construction and operations, these claims would have to be settled. Unpatented mining claims present similar problems.

The problem of mining activities is particularly significant because current activities within the proposed deployment area include gold, silver, copper, molybdenum, uranium, fluor spar, barite, alunite, and beryllium; and exploration activities for new deposits utilize state-of-the-art sensing equipment for detection of physical anomalies essentially the same as those involved in PLU discrimination.

#### Native American Claims

There are a number of complex Native American issues that are related to the proposed Nevada-Utah basing area, probably the most significant of which is the land claim of the Western Shoshone. The Western Shoshone claim that much of the land in the Great Basin was never ceded to the United States and rightfully still belongs to them pursuant to the Treaty of the Ruby Valley. This claim could be settled in many ways ranging from a cash settle-

ment to establishment of a new reservation, but failure to resolve the matter (which is currently in the courts) could leave a cloud on presumed Federal ownership of the proposed deployment area.

Other Indian land claims involve the designation of a future reservation for the recently created Paiute Indian Tribe of Utah (resulting from the amalgamation of several Southern Paiute bands and their restoration to a trust status in the 96th Congress), and possible disruption of the small Moapa Reservation (Southern Paiute) and Duckwater Reservation (Western Shoshone). Disruption of Indian water rights could also lead to litigable claims, and the desecration of sacred ancestral lands would clearly violate the protections of the Native American Religious Freedom Act

### Water Availability

In the arid lands of the West, water availability is a controversial issue for all growth and development: first, because the physical availability of water is limited; second, because physically available water may be unsuitable for proposed uses; and third, because institutional requirements for water rights are complex and often ambiguous

In the case of MPS, relatively high-quality water would be required for construction activities such as concrete preparation, revegetation, and domestic uses, and lower quality water could probably be used for aggregate washing, equipment cooling, and dust control.

The Air Force has estimated the total water consumption of MPS baseline between 310,000 and 570,000 acre-feet including construction, and a 20-year operation period, with a peak demand of 45,000 acre-feet per year (AFY) in the late 1980's and an annual requirement of 15,000 to 18,000 AFY during operations.

These estimates include requirements for the deployment area, operating bases, transportation systems, support facilities, irrigation of shelter sites and domestic uses of the work force, but do not include additional water for revegetation of other disturbed lands or es-

timates of larger work force populations. In terms of other large-scale projects, these requirements are roughly comparable to the requirements of large-scale coal-fired powerplants, that require about 10 AFY/MWe, and synthetic fuel plants, for which estimates of proposed facilities run from 4,000 to 20,000 AFY.

For the purpose of minimizing conflicts with existing water users, the Air Force has proposed using unallocated deep ground water reserves and has conducted preliminary tests of ground water resources. However, the use of deep water reserves poses several problems. In the proposed basing area of Nevada and Utah, the interbasin geology and hydrology is so complex that neither the resources of the deep aquifers nor their relationship to existing surface waters can be known with precision. Therefore, if ground water resources are utilized, effects on surface water and existing al locations would be difficult to predict. It is apparent, nonetheless, that if ground water resources are utilized, certain impacts and trade-offs will be involved:

- in some areas, water tables would be lowered and both the energy requirements and the costs of pumping water would be increased;
- surface seeps, streams, and wetlands might be reduced or eliminated, thus affecting livestock, habitat, and dependent species;
- dislocation of existing surface and ground water rights could be extensive and lead to subsequent litigation; and
- particularly serious water shortage problems and conflicts with prior users appear likely in the vicinity of the proposed operating base at Coyote Springs.

Moreover, uncertainties regarding these problems are compounded by the fact that shortcomings in monitoring and recordation yield only approximate figures in water depletion and water rights.

On the other hand, if the estimated needs of MPS are compared to the existing surface water allocations of the proposed deployment



area, it is apparent that sufficient water exists to accommodate the proposed baseline system. In comparison with an estimated annual water requirement of 15,000 to 18,000 AFY for operations and 45,000 AFY for peak year construction, there are 900,000 AFY of currently allocated water rights in the deployment area, and an estimated 300,000 AFY are allocated for future energy and mineral development, (See tables 7 and 8.)

Because the economic value of water is substantially greater for synthetic fuels and energy development than regional agriculture, proposed energy projects have been able to purchase necessary water rights from willing sellers (as in the case of the intermountain Power Project scheduled for construction in Delta, Utah, for which rights to 40,000 AFY

have been purchased). Presumably the Air Force would be able to find willing sellers with in the MPS deployment area.

“The United States could acquire existing water rights by eminent domain (condemnation) if Congress were to authorize such actions. However, even if existing land and water rights were not condemned, it is possible, given the scope of MPS requirements, that landowners, lessees, grazing permittees, and holders of existing water rights could contend that their rights had been either “taken” (and file claims for fair and just compensation), or “injured” (resulting in a legal claim for damages based on tort and trespass law).

on the other hand, OTA’s assessment indicates that ranching (and possibly mining) operations in the proposed basing area would probably close down in response to economic pressures, impacts on rangelands, and possible PLU restrictions resulting from MPS development. Moreover, the laws and regulations of both Nevada and Utah provide for the transfer of water rights on either a permanent or limited-term basis. For this reason it is likely that water would not be a limiting factor for MPS deployment unless it were necessary to construct more than 4,600 shelters or additional water was necessary for revegetation efforts. The issue of revegetation, however, is extremely controversial and pivotal to many of the physical impacts of MPS basing. Air Force estimates of water requirements include some water for revegetation of the missile sites, but no water for revegetation of disturbed lands.

Since there are no established methods for revegetation of arid lands without substantial irrigation, the total water required for revegetation could far exceed all available resources within the deployment area. Assuring an irrigation requirement of 1 AFY/acre, more than 3 million acre-feet could be necessary based on OTA’S calculations of possible land use impacts.

### Physical Impacts

Any large-scale construction projects involve physical impacts that are dependent on site-specific characteristics of the area. Con-

**Table 7.— Water Required for MX**

Year	A c r e - f e e t		Total
	Construction	Operation	
1981	168	0	168
1982	1,247	165	1,411
1983	6,807	510	7,317
1984	19,075	1,781	20,857
1985	26,744	3,760	31,825
1986	38,614	6,405	45,018
1987	37,653	9,545	47,199
1988	26,744	13,925	40,669
1989	12,906	17,615	31,464
1990	3,731	20,166	23,585
1991	2,152	20,166	22,319
1992	761	20,166	20,928
1993	262	20,166	20,475
1994	0	20,166	20,166
2000	0	20,166	20,166

SOURCE Air Force figures include DDA, OB, transportation system, support facilities irrigation of shelter sites, and domestic uses for operations personnel and their dependents

**Table 8.—Water Uses**

Irrigation	827,223
Livestock	2,514
Energy and minerals	65,330
Urban/industrial	13,593
Total	908,660
Future energy and minerals (period not indicated)	297,074

SOURCE MX Siting Investigation Water Resources Program Industry Activity Inventory Nevada, Utah, Prepared for U S D A F BMO/NAFB, by Fugro National, Inc ,02, September 1980

struction generally necessitates direct physical impacts on the soils, vegetation, livestock, habitat, wildlife, water quality, air quality, and other environmental characteristics of a region. The severity of these impacts depends on their particular characteristics and their magnitude, on the ability of the ecosystem to adapt and recover from disturbances, and on values subjectively placed on the changes that occur. In the case of MPS basing, the expansive grid-pattern of the system, the magnitude of the land-use requirements, and the utilization of lands that have inherently limited capacity to absorb and recover from disturbances, could lead to widespread desolation of the deployment areas.

The Air Force baseline proposal has been described as the largest construction project in the history of man, and it would involve, at a minimum, the disruption of 200 mi<sup>2</sup> of land for missile shelters, roads, and operating bases, as well as additional lands for temporary construction camps, haul roads, gravel pits, holding areas, and other construction related activities. In the absence of irrigated revegetation, or the presence of prolonged drought, the likelihood of these impacts would increase, possibly causing fugitive dust from decertified lands to contribute to drought conditions that could affect agricultural productivity outside the boundaries of the deployment area.

As indicated above, MPS basing requires a large deployment area, with a minimum of 4,600 shelters spaced at 1 to 2 mile intervals connected by 6,000 to 8,000 miles of roads throughout a geographic area of 12,000 to 15,000 mi<sup>2</sup>. The construction of these facilities would directly disrupt at least 200 mi<sup>2</sup> of land surface: but because arid or semiarid lands would be required and the impacts would be spread over a grid rather than confined to a bounded area, the attendant impacts could spread significantly.

### Impacts on Soils and Vegetation

The native vegetation of arid lands is necessarily highly specialized and inherently fragile, resistant to drought but vulnerable to the impacts of physical disturbance and vehic-

ular traffic. Throughout the arid and semiarid lands of the West, including the proposed deployment area and most of the geotechnically suitable candidate areas, "invader" species such as Halogeton and Russian Thistle have colonized rangelands rapidly following the physical disturbance of lands and the removal of native vegetation. These invader species offer protection against further deterioration of the soils by agents of erosion, but the protection is of limited value insofar as Halogeton does not provide nutritious forage and may be toxic to livestock. "Complete recovery (of disturbed lands)," the Air Force has stated, "may take a century or more. Long term establishment of Halogeton could prevent reestablishment of native vegetation, and it reversibly degrade the value of vegetation for future wildlife and livestock use."

Alternately, if not colonized by Halogeton or other "invader" species, the arid, loose-packed soils are vulnerable to structural disruption or compaction. When compacted the soils increase the frequency of water runoff and sheet-wash erosion, and when disrupted the loose particles become susceptible to wind erosion. In either case, the effects of erosion further degrade the land by altering both the physical and chemical profiles of the soil, and by impacting adjacent lands through the alteration of water flows and the abrasion of airborne particulates. Because arid lands generally have relatively low levels of biologic activity, soils are slow to reform, native species are slow to return, and the alterations of the land are likely to be irreversible without substantial human intervention.

The implications of these processes are of particular concern for MPS deployment because of the scale of the project and the potential for "spill-over" effects.

Although the Air Force claims to have been successful in confining the impacts of MPS-type construction activities to designated areas on test ranges, they have indicated that "a corresponding degree of success will prob-

ably be unlikely (in the case of MX MPS) due to the magnitude of the project, " and the amount of disturbed land is likely to increase throughout the construction stage while additional lands would be disturbed after construction as a consequence of off-road vehicle use and continued erosion<sup>4</sup>

Thus, the Air Force has indicated that in the absence of mitigation, "the significant adverse impacts from vegetation clearing would range from long-term to permanent, " Both as a result of the magnitude of the project and the particularly large interface between disturbed lands and undisturbed lands, the potential impacts could spread far beyond the 200 mi<sup>2</sup> directly disturbed by construction of the missile shelters, roads, and support facilities. The DE IS indicates that "the large number of cleared areas would result in a greater impact than would occur from the clearing of only a few such areas, "6 and "the more disturbed area, the larger the amount of vegetation lying around the perimeter of the cleared areas which will be subject to erosion and flooding " Consequently, the Air Force estimated that vegetative clearing and the associated secondary impacts of construction activities could extend up to 0.5 miles from points of direct disturbance. Although this figure was considered in the DE IS only as "rough index, " it clearly indicates the potential for extensive disruption of the deployment area,

If a vegetative disturbance area of only 0.25 miles from directly impacted lands is assumed, the construction of 8,000 miles of roads could result in devegetation of 4,000 mi<sup>2</sup> of land; and if a perimeter of 0.25 miles around each of the 4,600 missile shelters is considered, an additional 500 to 1,000 mi<sup>2</sup> of land could be lost (depending on overlaps with the impact zones of the roadways). Figure 36 illustrates this issue.

<sup>4</sup>Ibid, p. 4-99

<sup>5</sup>Ibid, p. 4-97

<sup>6</sup>Ibid, p. 4-97

<sup>7</sup>Ibid

<sup>8</sup>Ibid

<sup>9</sup>Ibid

On this basis, 5,000 mi<sup>2</sup> of productive rangelands could be lost in addition to lands impacted by operating bases, construction camps, haul roads, gravel pits, other construction related activities, and secondary development resulting from the population influx associated with MPS construction and deployment. If the impact perimeter is increased to 0.5 miles, as considered in the DE IS, the baseline system could impact 10,000 mi<sup>2</sup>. And if it is assumed that the "periodic sweeps" required by PLU activities would be concentrated in roughly the same land areas within 0.25 or 0.5 miles from MPS roads and missile shelters, then, as we have indicated, the impacts could be permanent.

To mitigate these impacts the Air Force has proposed a variety of measures, including the reapplication of surface soils where subsurface soils are of lower quality; stabilizing slopes; securing mulches; planting vegetation; "minimizing) repeated disturbance of planted areas from livestock and off-road vehicle (ORV) activity until vegetation is adequately reestablished;" and irrigating planted areas that receive less than 8 inches of rainfall per year.

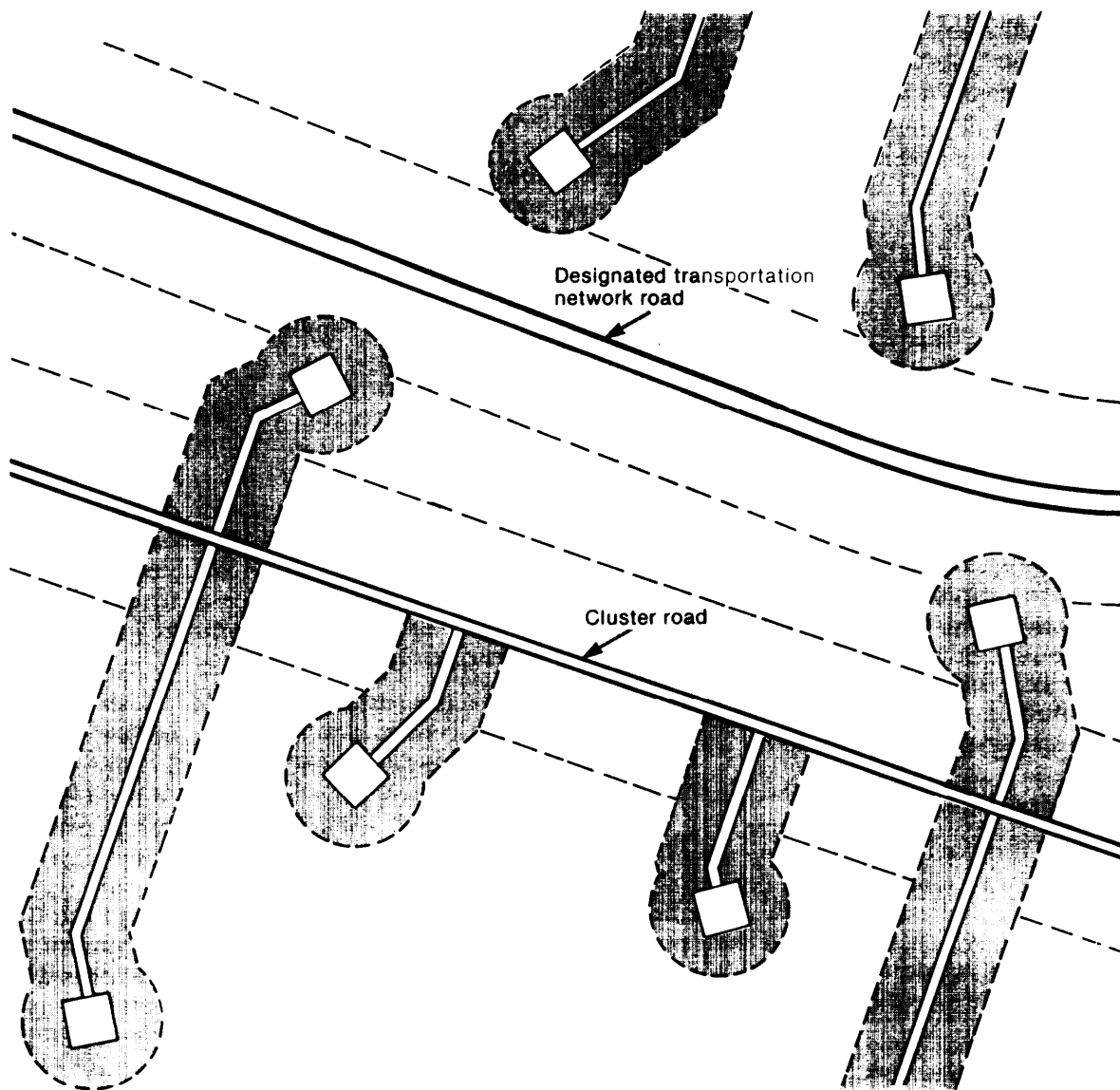
These last two mitigation measures are particularly important, not only because of their value to successful revegetation, but also because of the impacts they suggest on ranching operations, water requirements, and the costs of MPS deployment, As the Air Force notes:

Planting efforts usually fail in areas which receive less than 8 inches of precipitation annually (which includes roughly 80 percent of the projected disturbed area), unless irrigation is used. Revegetation water is not included in water estimates presented in this report [EIS] and would increase requirements significantly.<sup>9</sup>

In fact, if 1 AFY/acre is required for revegetation, and 5,000 mi<sup>2</sup> of land is disturbed by construction and secondary impacts, successful revegetation would require more than 3 million AFY. Even using much more conservative

<sup>9</sup> 4-99

Figure 36.—Potential Vegetative Impact Zone



SOURCE Off Ice of Technology Assessment

assumptions, the DEIS notes that “a comprehensive revegetation program would be very expensive.”<sup>10</sup>

These potential impacts of MPS development are especially significant in the context of western regional development. During the past decade, expanded energy development and population growth have greatly increased

<sup>10</sup> Ibid.

pressures on the physical environment to the point where they may be straining the region's life support systems and there is increasing concern about the potential spread of desertification throughout the region. Desertification generally refers to the degradation of arid lands to the point where they can no longer support life, and it tends to break out, “usually at times of drought stress, in areas of naturally vulnerable lands subject to pressures of land

use.”<sup>11</sup> Estimates of U.S. lands vulnerable to desertification range from 10 to 20 percent of the continental United States, and the President’s Council on Environmental Quality recently warned that the threat of continued desertification could have “far-reaching implications in terms of the Nation’s food and energy supplies, balance of payments, and its environment.”<sup>12</sup> Symptoms of desertification are already present throughout many parts of the arid and semiarid West—including overdraft of ground waters, salinization of topsoils and waters, reduction of surface waters, unnaturally high erosion, and desolation of native vegetation<sup>13</sup>—and projected expansion of Western energy resources will involve continued pressures throughout the region during the next decade.

In this context, any number of alternate impact scenarios, including expanded resource development, rapid population growth, off-road vehicle traffic, or prolonged drought conditions, could contribute to increased desertification: but MPS in arid lands, because of the magnitude of its grid configuration, clearly poses the greatest potential threat.

### Weather Modification

Desertification within the deployment region also raises questions of potential atmospheric effects that are highly speculative at this time, but which, because of their potential implications for domestic agricultural productivity, deserve attention.

The Air Force has calculated that “fugitive dust” emissions from MPS construction (based on 200 mi of land disturbance) would result in tenfold to twentyfold increases in atmospheric particulate, and violations of standards promulgated under the Clean Air Act. These emissions would degrade air quality over a wide area (including several national parks), and there is a possibility that health problems

could result from spore-laden dust churned up from the desert soil,

other concerns, however, are suggested by recent studies of atmospheric particulate that suggest that climatic effects may result from increasing aerosols of fine particulate in the lower atmosphere. While the back scattering of solar energy tends to decrease total atmospheric heating and thereby cool the lower atmosphere, absorption of radiant energy by particulate matter tends to increase the temperature while simultaneously acting as condensation nuclei that adsorb moisture and retard cloud formation. The net result of these effects, depending on their relative magnitudes and a variety of other considerations, could be to increase temperatures in the lower atmosphere and decrease precipitation. Moreover, these effects may be most likely in arid regions, as evaporation from moisture in more humid climates would tend to offset the increasing temperatures brought about by absorption of radiant heat.

The long-distance transport of fine particulates from desert regions of the world has been well-documented, but the potential effects of resulting climatic alterations are unknown. If a causal relationship exists between fugitive dust emissions and downwind weather modification, extensive fugitive dust emissions from MPS deployment in the Great Basin could have substantial economic impacts on agricultural productivity outside the deployment area; and as in other matters discussed in this section, drought conditions during the construction period would exacerbate the potential threats.

### Least Productive Lands

Finally, in considering the physical impacts of MPS basing, it should be noted that the Department of Defense Supplemental Appropriation Act of 1979 included “the sense of Congress that the basing mode for the MX missile should be restricted to location on the least productive land available that is suitable for such purpose.”<sup>14</sup> Accordingly, the pro-

<sup>11</sup>United Nations Conference on Desertification, Aug. 29-Sept. 9, 1977 Plan of Action and Resolutions, pp. 1-2. New York, 1978.

<sup>12</sup>Desertification of the United States, President’s Council on Environmental Quality, Washington, D.C. 1981.

<sup>13</sup>Ibid.

<sup>14</sup>Public Law 96-29, 6/27/79.

posed deployment area in the Great Basin of Nevada and Utah reflects this criteria. It is not the *least* productive land among the geotechnically suitable areas; but it is *among* the least productive, and is considerably less productive than the High Plains regions that extend from Texas and New Mexico up through Colorado and Nebraska to Wyoming,

However, the more productive agricultural lands have an inherently greater capacity to absorb the impacts of construction activities and, in contrast to the Great Basin, could be revegetated with relative confidence. For this reason, the total amount of land lost to agricultural productivity might be considerably less than in areas where revegetation is more difficult. If it is assumed that 200 mi<sup>2</sup> of land would be lost in a grassland ecosystem and that the market value of crops is \$80/acre/yr, then the total economic loss associated with this basin option would be approximately \$10.2 million per year. And if twice as much land would be lost to agricultural productivity in the Great Basin, with the market at approximately \$5/acre/yr, then the net agricultural loss would still be less than 10 percent of the lost crop value in a grassland ecosystem. Based on this rough estimation, 3,200 mi<sup>2</sup> of rangeland would have to be lost to equal the lost agricultural value of 200 mi<sup>2</sup> of crop land.

Therefore, if the impacts of MPS construction can be confined to the designated areas during construction, and mitigation measures are not very expensive, the economic costs of deployment in "least productive lands" would appear to be considerably less than in more productive croplands. But if it is assumed either that the impacts will spread in arid lands, or that mitigation measures to prevent the spread of impacts will be more than \$10 million per year, the economic costs of "least productive lands" are likely to be at least as great as the costs of using more productive lands

<sup>\*</sup>This cost equation is, in fact, much more complicated, and is dependent on a wide range of highly uncertain variables. Nonetheless, it illustrates the approximate form of the tradeoffs involved

## Socioeconomic Impacts

The socioeconomic impacts of MPS basing, like the physical impacts, are closely related to the siting criteria. As previously noted, the criteria require sparsely populated areas for the purpose of minimizing the interface between the public and PLU activities. In theory, selection of a deployment area with a minimum number of people might ensure that a minimum number of people would be affected by the rapid growth associated with MPS construction. In reality, MPS construction is likely to affect not only the residents of the deployment area, but migrants drawn to the area by MPS construction opportunities, residents of surrounding urban areas, and communities dependent on regional energy development that could be constrained by MPS manpower and materials requirements. The affects, however, would be varied. On the one hand, construction activities would provide new jobs and employment opportunities, higher wages, and the potential for accelerated regional development, including expanded economic activities and community services; and once completed, the operating personnel associated with MX/MPS would provide a stable economic base within the surrounding community. On the other hand, the process would transform the economic structure of the existing communities and pose enormous problems of growth management resulting from uncertainties in the size and regional distribution of the project work force and secondary populations.

## Community Impacts

The literature of socioeconomic impacts associated with western energy resource development clearly indicates that there are many adverse affects associated with rapid growth, and the single most important factor that influences these impacts is the size of the existing community population prior to development.<sup>15</sup> In general, communities with

<sup>15</sup>For more information, see *BLM Social Effects Project Literature Review*, prepared for the Bureau of Land Management, Department of the Interior by Mountain West Research in Association with Wyoming Research Corp. in draft, January 1981

larger populations (at least 10,000-25,000 people) have the capacity to absorb greater population influxes without suffering adverse affects. To the extent that infrastructures of housing stock, schools, roads, sewers, health care facilities, and administrative services all exist prior to rapid growth, these facilities often can absorb much of the population increase, and the marginal costs of expanding services and facilities are relatively small. Insofar as the Air Force siting criteria for MPS exclude areas with cities of more than 25,000 people within 20 miles, adverse socioeconomic effects would be essentially unavoidable.

Based on recent experience with Western energy resource development, these impacts would include a restructuring of the local job economy as new jobs are created and existing residents change jobs in hope of new opportunities and higher wages; changes in the lifestyle of relatively isolated and closely integrated communities; inadequate housing, roads, sewers, schools, health care facilities and administrative services; regional wage and price inflation; and increased stresses on individuals, families and communities. It is also worth noting that local residents are usually unable to compete successfully with new migrants for skilled labor positions and higher paying jobs, and that few new jobs go to unemployed residents of the area, fewer still to women and minorities, and virtually none to Indians.

As a consequence of the influx of new migrants with a relatively high proportion of well-educated or skilled laborers, competition for jobs does not always benefit existing community residents. Existing businesses are often unable to compete with the higher costs of wage and price inflation; new small business operations are frequently unable to compete with the high capital costs and risks associated with meeting rapidly expanding business opportunities; existing residents may resent the influx of new residents and associated changes in community lifestyles; incoming residents often find adjustment to reduced levels of social services and amenities difficult; and in-

creases in alcoholism and child abuse tend to appear as manifestations of these increasing community pressures.

Finally, in the isolated ranching, mining, and farming communities of the Western States, social ties between families and neighbors tend to be especially strong, and both administrative government and the provision of social services may be deeply rooted in informal community mechanisms. This relationship is true in general throughout the isolated communities of the Western States, and it is particularly true of the Mormon communities of southern Utah, in which the integral relationship between church, family, and community would be profoundly disturbed by the influx of a large number of migrants who could not be assimilated into the fabric of this culture.

These issues are complicated by the fact that the Western States are in a process of rapid growth and transformation, and that virtually all of the available literature has been drawn from experiences with western energy resource developments that have been relatively large in relation to the existing community sizes, but that are relatively small in comparison with the manpower requirements and geographic expanse of MPS. In contrast to large-scale coal-fired powerplants and synthetic fuel facilities with construction work forces of 2000 to 5,000 people, located at specific sites that could be clearly defined in relation to the surrounding communities, estimates of the baseline construction work force for MPS range from 15,000 to 25,000 people; and the Air Force is considering the use of as many as 18 temporary construction camps spread throughout a geographic area of 15,000 m<sup>2</sup> for construction of MPS. Furthermore, there is evidence to suggest that in several instances the net impact of rapid growth on small communities has been positive. Following the boom-bust cycles of rapid growth and decline, the communities have readjusted to lifestyles closely resembling preimpact conditions, but with the added benefits of expanded facilities resulting from an increased population base,

Thus, it might be the case that individual communities within the deployment area might benefit from MPS deployment, or alternately, that the effects of MPS deployment might be indistinguishable from the effects of accelerated mineral resource and energy development in surrounding areas. In general, however, it appears that the residents of small communities in the deployment area would be unlikely to benefit from MPS development, and probably would face the loss of existing ranching and mining operations within the area.

At the same time, the larger urban areas on the periphery of the deployment area would be affected by MPS development in a totally different way. Unlike small towns faced with neither the administrative nor the financial capacities to accommodate large-scale growth, larger urban areas with these capabilities would be faced with uncertainties regarding the magnitude and the location of the growth that might occur. Unlike large-scale energy developments in which clearly defined locations for planned facilities reduce the uncertainties of planning decisions to questions of timing, financing, and scale, the magnitude of MPS and geographic dispersion of the proposed development complicates these issues substantially.

In contrast to large-scale powerplant developments with construction work forces of 2,000 to 4,000 people, estimates of the onsite work force required for MPS development range from 15,000 to 25,000, and OTA's analysis indicates that actual construction work force requirements could be as high as 40,000 people. In this case, the total population impacts of MPS could be in excess of 300,000 people. Because regional economic impacts are a function of the magnitude and distribution of the work force population and associated growth, and the range of possible population impacts is so great, it is worth looking at the basis for these figures in some detail.

### Work Force Estimates

The Air Force has estimated that MPS construction would require a peak construction

work force of 17,000 workers and a total population of slightly more than 100,000 during a period of overlap between construction activities and initial operations.

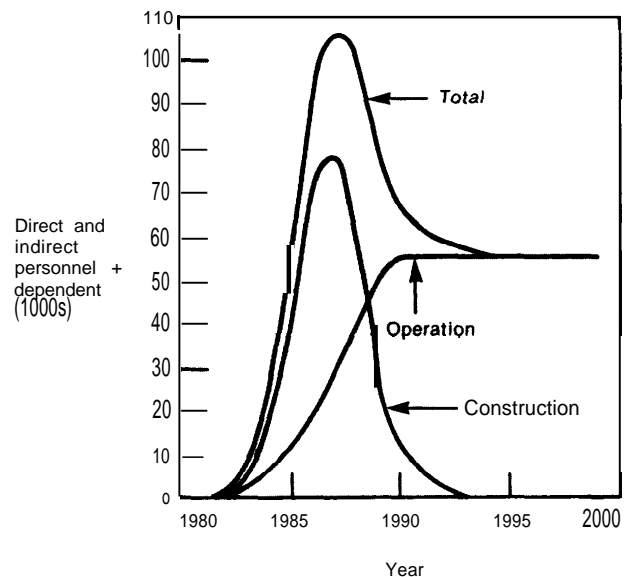
Figure 37 illustrates the approximate relation between the population of the construction work force, operating personnel, and their dependents.

In fact, these figures represent conservative estimates. By the time the DEIS had been prepared, the construction work force figures had been revised upwards almost 40 percent\* — and they fail to reflect the uncertainties that are associated with all of these estimates.

Figure 38 illustrates the direct construction work force estimates (including onsite and "life support" labor) of the Air Force, the Army Corps of Engineers, and joint Air Force/Army Corps task force on manpower estimates. Figure 39 illustrates the relationship between on-

\* The Draft Environmental Impact Statement on Area Selection was published along with an errata sheet which contained revised work force estimates based on a joint task force of the Air Force and the Army Corps of Engineers, but the analysis contained in the report was based on the earlier (lower) estimates.

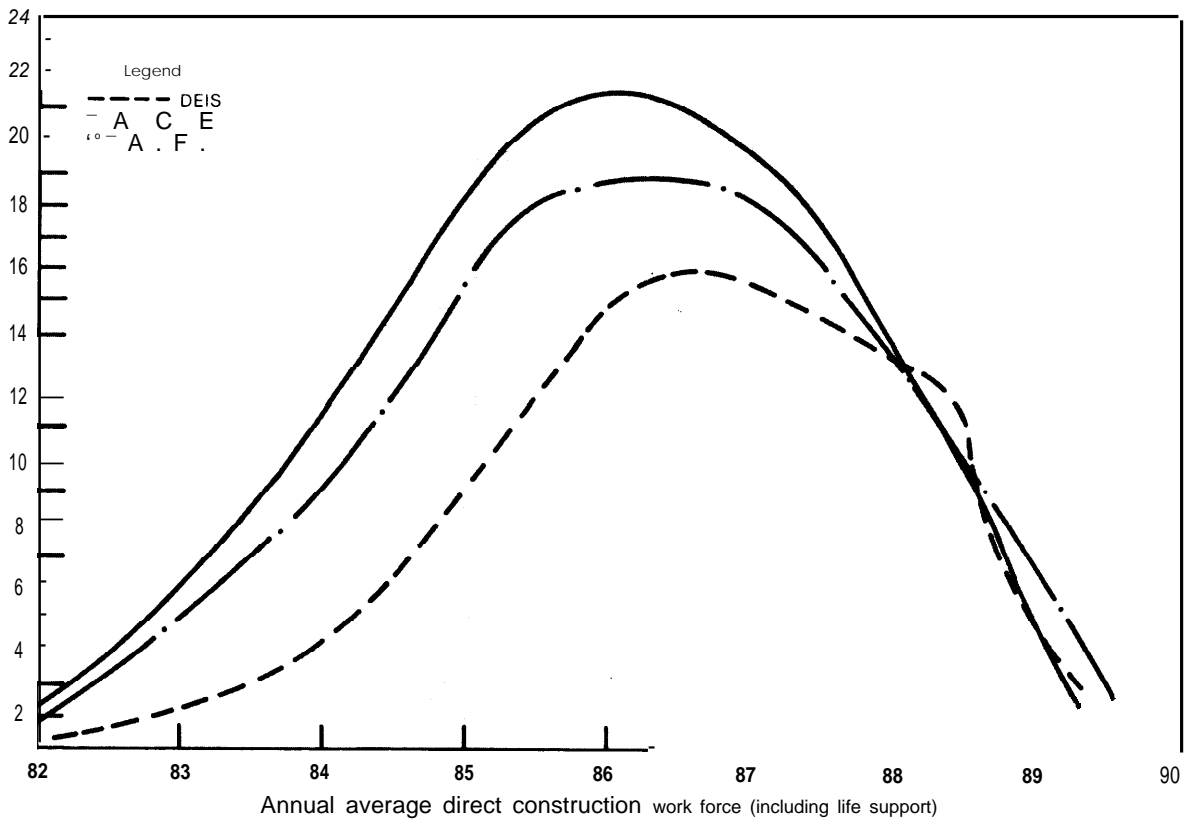
**Figure 37.—Construction Work Force, Operating Personnel, and Secondary Populations**



SOURCE: U.S. Air Force



Figure 38.— Baseline Work Force Estimates



A. F./DEIS 1,150	2,000	4,450	10,800	17,050	15,450	13,050	4,800
ACE 1,160	6,940	14,305	19,750	23,730	16,900	12,670	4,725
A. F./ACE 2,035	5,590	9,510	17,910	18,560	17,670	12,765	5,490

SOURCE A F /DEIS Chapter 1, Errata Sheet, Table 11

site construction labor estimates and estimates of the total construction work force required.

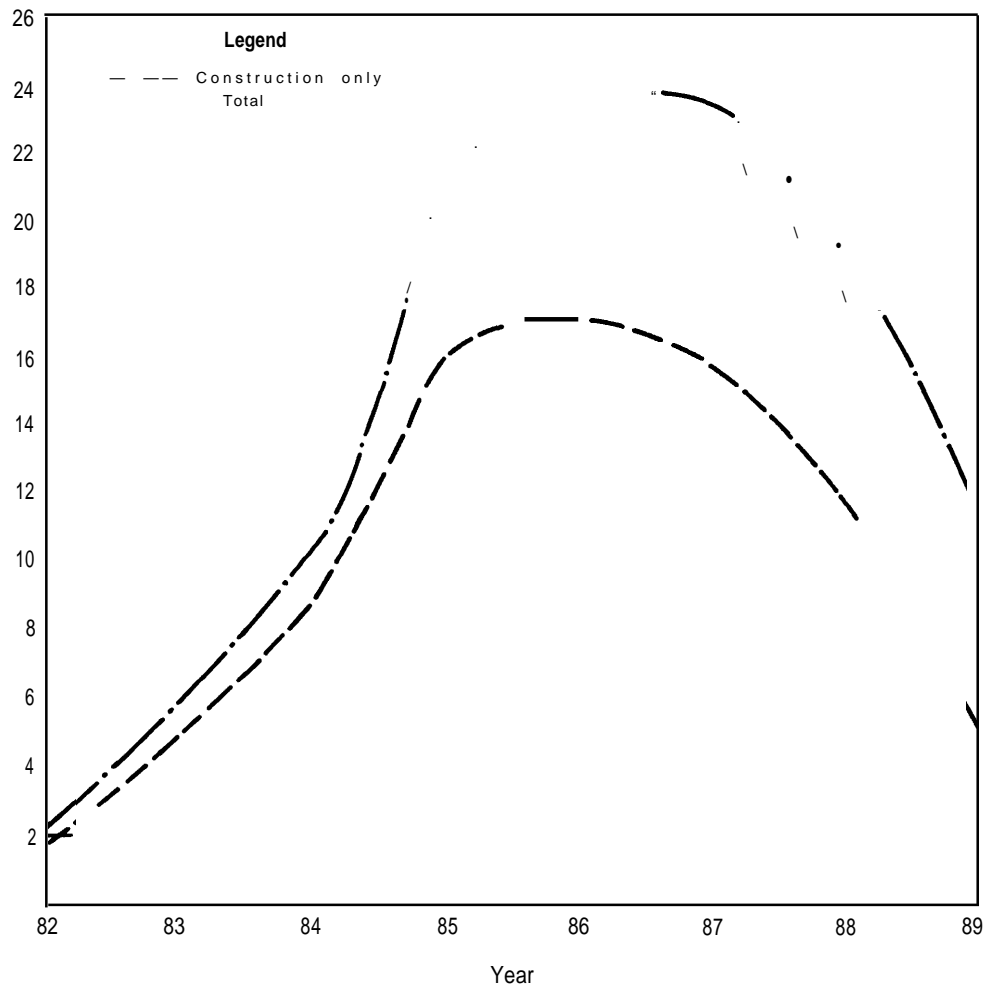
Estimates of the costs and manpower requirements of major construction projects, however, have characteristically underestimated actual costs and manpower needs. Evidence from various studies of this problem suggests that these overruns result in part from revisions in engineering designs while construction is in progress, delays caused by late deliveries of major components or bottlenecks in materials supplies, and difficulties in utilizing manpower and materials efficiently on a time-urgent schedule. Tables 9 and 10 provide two indices of these problems. Table 9 in-

dicates the average cost overruns in weapons systems, public works projects, major construction projects, and energy process plants, and table 10 compares the projected and actual manpower needs of large-scale coal-fired powerplants.

If all overrun factor of 73 percent is assumed on the basis of the average manpower overrun associated with coal-fired power-plants in the West \* the manpower estimates for MX/MPS would increase to more than 42,000. As a I so

\* The average manpower overrun from coal powerplants in the West is used here because it represents construction of a "known technology" (rather than a "new" technology) in the arid West. Other projects such as nuclear powerplant or synthetic fuelplants involve higher degrees of new technology development.

**Figure 39.—Comparison of Onsite and Total Construction Work Force**



Construction only	1,832	5,031	8,559	16,120	16,700	15,900	11,490	4,941
Life support	203	559	951	1,790	1,660	1,770	1,275	549
Assembly and check out	0	400	1,000	3,550	6,000	6,000	5,900	5,750
<b>Total</b>	<b>2,034</b>	<b>5,990</b>	<b>10,510</b>	<b>21,460</b>	<b>24,564</b>	<b>23,670</b>	<b>18,665</b>	<b>11,240</b>

SOURCE Office of Technology Assessment

**Table 9.—Cost Overruns in Large-Scale Projects**

Type of system	Actual cost/ estimated cost
Weapons system . . . . .	1.40-1.89
Public works . . . . .	1.26-2.14
Major construction . . . . .	2.18
Energy process plants . . . . .	2.53

SOURCE Office of Technology Assessment, 1981

noted (see pp. 42-44 and 86-89) MPS construction might require an accelerated schedule to build 8,250 shelters by 1990, in which case manpower requirements would increase another 60 percent to almost 68,000 construction workers. Figure 40 indicates the total construction work force required if the baseline figures were increased 60 percent to allow for

**Table 10.—Estimated and Actual Construction Work Forces for Coal-Fired Powerplants**

Plant (and State)	Estimated peak	Actual peak	Percent change
Antelope Valley (N. Dak.)	840	1,370	+ 63
Boardman (Oreg.)	760	1,482	+ 83
Clay Boswell (Minn.)	900	1,560	+ 73
Coal Creek (N. Dak.)	980	2,113	+ 91
Laramie River (Wyo.)	1,390	2,200	+ 58
White Bluff (Ark.)	1,100	1,900	+ 72
Average overrun			+ 73

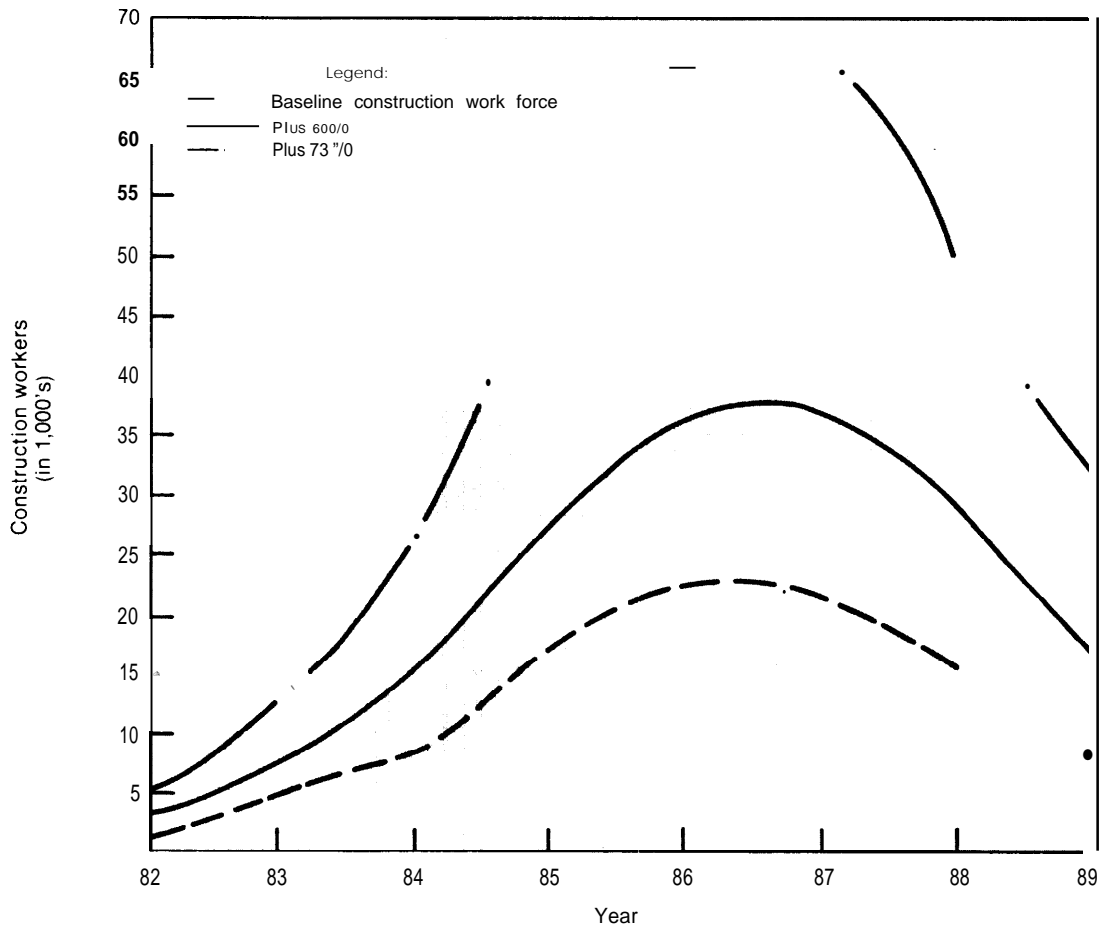
SOURCE: Gilmore/DRI.

an accelerated construction schedule and 73 percent to allow for manpower overruns.

Population Estimates

Similar uncertainties affect estimates of the secondary populations associated with the construction work force. Assumptions must be made regarding the ratio of new secondary employment (e. g., construction of new housing, grocery stores, gas stations, etc., ) by MPS con-

**Figure 40.—Construction Work Force: High-Range Projection**



Baseline construction work force	2,034	5,990	10,510	21,460	24,560	23,670	18,666	11,240
Plus 50%	3,051	8,985	16,816	34,336	39,296	37,872	29,864	17,964
Plus 73 %/0	5,630	16,860	29,091	59,401	67,993	65,518	51,664	31,112

SOURCE: Office of Technology Assessment

struction and operations, and additional assumptions must be made regarding the demographic characteristics of the construction work force. Despite the fact that the characteristics of western energy project construction labor forces have been studied, significant uncertainties exist, and the population impacts of MPS could vary considerably depending not only on the number of construction workers involved, but the relative numbers of single and married workers, and choices they make regarding residential locations and commuting alternatives. Using the Task Force baseline es-

timate of construction work force size (see fig. 38), figure 41 illustrates the range of secondary population growth associated with the base case assumptions using three different sets of demographic assumptions,

Finally, if these factors are considered in conjunction with one another, a wider range of population growth scenarios results. Figure 42 illustrates the range of possible population growth scenarios resulting from alternate assumptions regarding the location and demographic characteristics of the primary work

Figure 41.— Range of Secondary Population Growth

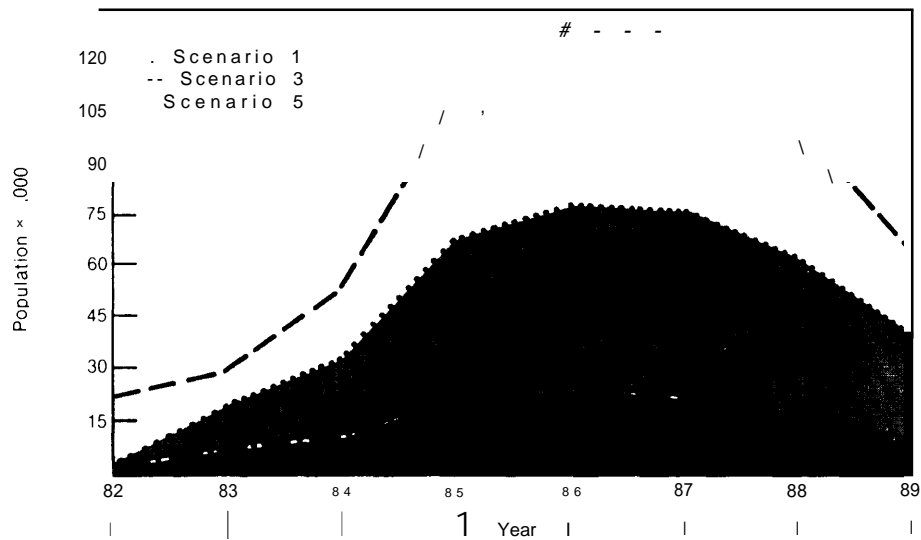


Table 2 summarizes these data:

Scenario 1	3,404	18,289	32,576	67,681	78,796	76,949	62,035	38,699
(x 1.73)								
Scenario 2	2,839	12,594	22,382	27,789	53,595	51,917	41,895	25,944
(x 1.73)								
Scenario 3	4,356	29,689	53,167	110,876	129,458	126,668	102,449	64,333
(x 1.73)								
Scenario 4	2,493	7,380	12,872	26,346	30,313	29,371	23,313	14,169
(x 1.73)								
Scenario 5	2,174	6,412	11,275	22,940	26,303	24,629	20,070	12,127
(x 1.73)								
	1982	1983	1984	1985	1986	1987	1988	1989

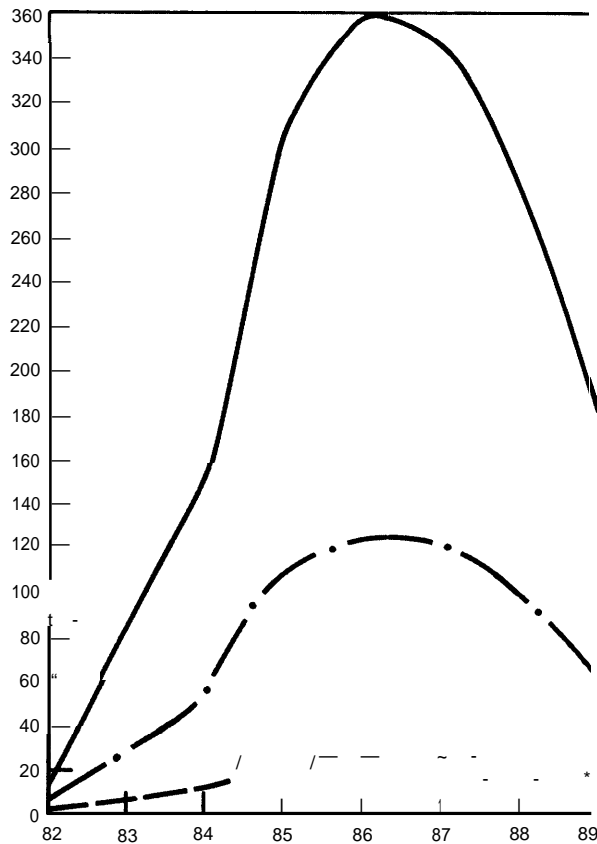
Scenario 1 0.511 single + 0.489 married  
 Scenario 2 0.375 single + 0.25 married + 0.375 shuttled  
 Scenario 3, all workers married  
 Scenario 4, all workers single  
 Scenario 5 all workers shuttled

SOURCE ERC p20/Office of Technology Assessment

\* /footnote from page 25

SOURCE Office of Technology Assessment

Figure 42.— Range of Potential Population Growth



**Accelerated construction;**  
 73% overrun;  
 all workers married  
  
**Accelerated construction**  
 50% married workers  
  
**A.F. Base case;**  
 no overruns;  
 all workers shuttled

Accelerated construction; 73% overrun; all workers married	12,057	82,179	147,166	306,904	358,339	350,617	283,578	178,073
Accelerated construction 50% married workers	5,446	29,262	52,121	108,289	126,072	123,118	99,256	61,918
A.F. base case; no over- runs; all workers shuttled	2,174	6,412	11,225	22,940	26,303	24,629	20,629	12,127

SOURCE Office of Technology Assessment

force, the rate of MPS construction, and the possibility of an overrun in construction labor requirements.

If the operational personnel and dependents are also factored into this scenario, the peak population would obviously increase. From the standpoint of regional growth management, the magnitude of MPS development and the uncertainties inherent in the population growth scenarios pose serious economic problems. Based on Air Force estimates of projected population growth, OTA has estimated that the costs of socioeconomic mitigation could run as high as \$7 billion during the construction and operation of MX/MPS, and adverse impacts would result either from the underinvestment in capital facilities, or from overinvestment. Furthermore, because MPS would involve such a large geographic land area, these uncertainties are compounded by the fact that it cannot be known precisely where various levels of development would take place.

The social impact assessment literature clearly suggests that one of the instrumental factors in successful impact mitigation is the process of political negotiation with impacted communities to plan for social change, economic development, and growth management. In the case of MX/MPS the highly speculative nature of population distribution and impacts, together with the urgency of the time schedule for construction, would effectively preclude such planning to optimize the potential benefits or mitigate the adverse impacts of MX/MPS.

### Regional Energy Development

The socioeconomic impacts of MPS are further complicated by the likelihood that MPS basing would affect the availability of manpower and materials for regional energy development. During the past 10 years, domestic energy developments have been affected by delays and constraints caused by shortages of skilled labor and critical materials. During the next decade most of these constraints are anticipated to continue and to the extent that

MPS requirements overlap, they could further inhibit regional energy development.

Initially, MPS would require substantial amounts of basic construction resources, such as concrete and steel. Although it does not appear that MPS baseline construction would overwhelm the existing markets for these materials, it is likely to strain the transportation network that supplies these materials throughout the Western States, and in the event that an expanded system were necessary, industrial capacity would have to be expanded.

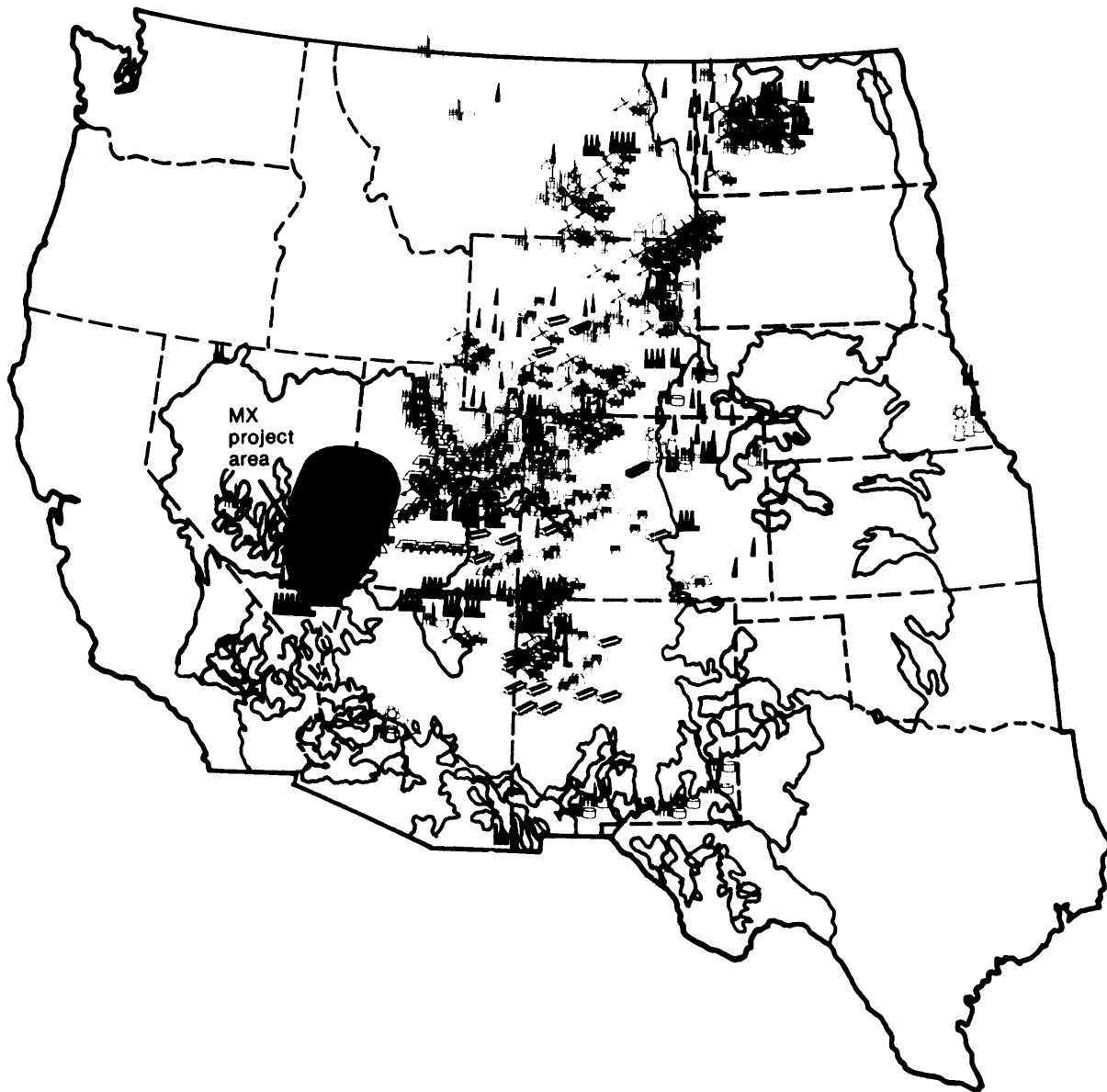
Secondly, MPS would require certain critical materials, including special metal alloys, castings, and forgings, that could create bottlenecks in supply. The domestic castings and forgings industry has little flexibility, and if specialized components are required for 4,600 shelters, constraints could affect availability in the energy and aerospace industries.

The Air Force has identified a general list of critical materials, but information regarding material components may be related to PLU design considerations, and OTA has been unable to identify more information regarding special materials and alloy requirements. Conversely, MPS could affect domestic supplies of critical materials if PLU requirements constrain mineral exploration and development in the deployment area. The proposed basing area contains gold, silver, mercury, barite, lead, molybdenum, tungsten, zinc, and lithium.

Finally, based on estimates of the skilled labor forces necessary for this energy development, and analysis of the training programs currently available in the Western States, shortages of skilled labor appear inevitable in western energy resource development.

As can be seen in figure 43, all of the candidate areas occur within a multi-State region that currently employs 280,000 people in energy and nonfuel mineral development. Because the construction labor force for this development, including general construction labor, semi-skilled and skilled tradesmen, engi-

Figure 43.—Cumulative Energy Activity in the West



SOURCE AbtWest. 1981

neers, and experienced managers, is regarded as highly mobile and projected to be in short supply, the labor requirements of MPS construction could affect resource development throughout this 10-State area. Training programs are underway to offset some of these labor shortages in several States, but they are unlikely to have a major effect on the shortages because many of the skilled positions require training and experience (that are in turn

dependent on skilled instructors) and because the demand for labor changes rapidly with construction plans and schedules.

### System Schedule

The MX/MPS schedule is highly success-oriented and requires specific actions by Congress if both IOC and FOC are to be achieved. Given these actions and no major develop-

ment problems, it is possible both dates can be accomplished. In all probability, however, some slip in IOC should be expected. The current DOD review of basing options is delaying actions required to ensure even a possibility of meeting IOC Unless a timely decision is made, leadtimes required will inevitably cause a delay in achieving the IOC date.

**Table 11.—System Time Schedule**

Land withdrawal application filed	7181
Legislation to Congress	1/82
Legislation approval	5182
SATAF activated	1182
Start construction to operating base	4182
First missile test flight	1/83
Missile production contract award	7183
DSARC III-missile	7183
Start construction in deployment area	1/83
First cluster available	8/85
Full base support available	9185
Initial operating capability	7186

SOURCE: Office of Technology Assessment

Most of the land required for the preferred Air Force basing location for MX/MPS is Federally owned and under the control of the Bureau of Land Management, Department of the Interior (DOI). Transfer of the necessary land to DOD requires congressional approval. The schedule, as planned by the Air Force, is predicated on a basing decision in June 1981, and allows a public comment period between July and October, with the legislative package ready for congressional consideration in January 1982. Final approval and land availability is scheduled for May 1982.

A June 1981 basing decision did not take place while the Air Force and DOI are exploring means of expediting the withdrawal application process, the application must be specific in terms of base and deployment area, and both the land withdrawal application and congressional enabling legislation will have to address complicated issues such as the land claims of the Western Shoshone and State school lands in Utah. Slippage of the land withdrawal action would impact all other dates associated with base and deployment area construction and leadtimes would also be required to ensure adequate electric power supplies, to purchase water rights where needed, and to obtain necessary permits. Although

it is difficult to assess the extent of slippage likely to occur, it is doubtful that an IOC of 1986 can be met, and system costs would escalate along with any slippage in IOC. Foreseeable slippages could also impact FOC, although a slip in IOC would not necessarily delay final operating completion,

The missile deployment and production schedule may also present some problems. A production decision is scheduled early in the flight test program, and, in fact, before the missile-cannister-shelter tests take place. In addition, long leadtime materials' authorization is scheduled to occur in February 1983, or 1 month after first flight and 5 months before the production decision. Problems in the flight test program under these conditions could lead to overall program delays, renegotiation of production contracts, and, perhaps, substantially increased costs. It is also not clear that the Air Force has the authority to release contracts for long leadtime material before the production decision is formalized.

The countermeasures subsystem, both for the missile and for the decoy system, also may present scheduling difficulties. Long leadtime items for prototype systems were scheduled for approval in April 1981. This has not occurred, and the delay will probably postpone initial deliveries of prototype hardware and impact on qualification tests and perhaps the missile test program itself.

The formal submittal of a budget estimate for funding deployment area construction is scheduled for October 1981. This submittal will include an update of Military Construction Program (MCP) costs based on the outputs of the 1980 Systems Design Review a site-specific estimates of protective shelter cost. The uncertainties introduced by the DOD review of basing options tend to inhibit the development of background material and internal Air Force-DOD review of the revised baseline estimates supporting the budget request. Delays in the basing decision may make it difficult for the Air Force to adhere to the normal budgeting schedule and produce estimates with the degree of accuracy required. This problem will



be intensified if the basing decision is other than horizontal shelters in the Nevada-Utah area

In OTA'S judgment, the IOC date is likely to slip 6 months to 1 year. A slip in IOC date would increase costs by approximately \$7s million per month, so that the anticipated increase in MX/MPS cost would be on the order of \$0.5 billion to \$1,0 billion. Given a decision to proceed with adequate funding on a year-to-year basis, OTA believes that the FOC date could be achieved even with the IOC Slippage. This belief is predicated on the fact that funding and procedural mechanisms are provided so that long leadtime resources can be marshaled for use when required,

### System Cost

OTA had an independent cost assessment conducted of the Air Force baseline system. The cost was estimated for all stages of the system, from development and investment through operation and support for 10 years of deployment.

In determining system cost, it should be understood that the baseline configuration for MPS is not yet firmly fixed, as certain technological tradeoffs are still being considered by the Air Force. The Air Force is in the process of updating costs, but until the baseline configuration is finalized, new estimates are considered internal Air Force data and were not made available for OTA'S analysis. In lieu of this data, the Air Force provided detailed briefings covering methods used to estimate costs and provided substantial backup material to support their *previous* estimate of \$33.8 billion (fiscal year 1978 dollars) In addition, the draft environmental impact statement (DE IS), particularly its technical appendices, contains additional information useful for estimating costs. Also, some of the design changes adopted as a result of the late-1980 design review have been incorporated into the estimate. Inputs drawn from the backup material supplied by the Air Force have been used but appropriate adjustments have been made, based on information contained in the DE IS

and other published sources. Therefore, a systems configuration has been selected as a basis for cost analysis that is compatible with Air Force plans but which is Slightly different in detail from the configuration used for the previous Air Force estimate

There is some confusion about the Air Force baseline estimate A cost of \$33.8 billion is often quoted This dollar figure refers to the baseline estimate, in constant 1978 dollars, and includes 1 (-)year O&S (operation and support) costs for a total lifecycle cost This figure when escalated to 1980 dollars is \$399 billion lifecycle cost, with a total acquisition cost of \$338 billion (This estimate also excludes the cost of impact mitigation ) The Air force's baseline estimate for the 4,600" shelter system is shown in table 12

**Table 12.—Air Force Baseline Estimate 4,600 Shelters (June 1978) (billions of dollars)**

	FY78\$	FY80\$
<b>Development (RDT&amp;E) . . . . .</b>	<b>\$ 6.7</b>	<b>\$ 7.9</b>
<b>Investment</b>		
<b>Aircraft procurement . . . . .</b>	<b>\$ 0.3</b>	<b>\$ 0.3</b>
Missile procurement . . . . .	12.6	14.9
Military construction . . . . .	9.0	10.7
Total investment . . . . .	\$21.9	\$25.9
Total acquisition . . . . .	\$28.6	\$33.8
O & s costs . . . . .	\$ 5.3	\$ 6.1
Lifecycle costs . . . . .	\$33.8	\$39.9

SOURCE U S Air Force

Because of the controversy over these estimates, it is important to understand the conditions under which they were developed, and their degree of accuracy. The MX Program has considered a wide variety of basing modes, including silos, trenches, and air mobile in addition to the present horizontal plan. For each basing mode, several configurations were studied and costed, an important consideration for each mode. In order to have a quick-response estimating capability with a reasonable degree of accuracy, a cost model was developed by the Air Force. This model was parametric, in which cost factors were developed for specific characteristics (or parameters) that describe a particular function, and

required resources such as transportation and handling costs. This model was used to develop the Air Force's June 1980 estimate for MPS.

After reviewing the Air Force model in detail, it appears that the methods used in it are sound and reflect serious considerations of the major problems to be overcome in completing the MPS option. The estimates, therefore, have a reasonable degree of validity and accuracy, and it is possible that the acquisition process could be completed within the \$33.8 billion estimate. For several reasons, however, OTA believes that the cost would be about \$3.5 billion greater than this estimate. Program delays are already putting upward pressure on potential MPS costs, and additional delays in the construction process should be expected.

Furthermore, any cost estimate at this time must contain a high degree of uncertainty. Generally, it is hoped that an underestimate of one item will be offset, at least partially, by an overestimate of another item. Conditions under which the MPS program is being conducted—optimistic schedule, massive scale, remote location, and new technology—put pressure for cost growth on almost all elements of the program. A clearer picture of the limits of expected costs can be obtained only after a number of significant issues are resolved.

Deployment is planned for a very remote, sparsely populated area that does not have the necessary infrastructure to supply meaningful support to the construction activities required or to absorb easily the influx of service and contractor personnel required to operate and maintain the system once in place. In addition, some of the deployment area is of historical and archeological interest, imposing limits on the siting and construction of MPS facilities and roads. These conditions have impacts on the costs of the MPS system. OTA's cost estimate, therefore, concentrates on detailing the resource requirements to develop, procure, construct, and operate the system. Construction and check out of facilities and equipment systems present a most severe problem in cost

estimating. While it is not too difficult to estimate the construction cost of a given structure, the estimating process becomes very complex under the conditions that exist for MPS. First, the workers must be recruited outside the deployment area since the skills and numbers required probably do not exist locally. Because of this situation, temporary construction camps must be established and housing, food, recreation, and health care must be provided for the workers. Everything from construction materials to loaves of bread must be brought into the area over what is, at best, a limited transportation network. In addition, the technical facilities must meet exacting standards to ensure survivability, postattack launch capability, and to protect PLU. Thus, in addition to construction workers, there must be managers and inspectors to ensure quality control, personnel to prepare food, truck drivers to provide transportation, clerks to receive and store materials, and a number of other supporting personnel. Solid and liquid waste must be disposed of in an environmentally acceptable manner.

Other areas where precise cost estimates are difficult include:

- **MX missile.** The decision for full-scale production is scheduled to be made long before the flight test program is completed and before the missile/cannister combination has been tested. Such a program is feasible, but risks complications late in the test program causing design changes, delays, and production cost increases over those estimated.
- **Missile Decoy.** This system, vital to the viability of MPS is not yet fully designed. Projected development and procurement cost are highly uncertain at this time.
- **Missile Transporter.** This transporter will be the largest truck-like vehicle ever constructed and it includes highly sophisticated automatic controls, communications, and decoy systems.
- **Command, Control, and Communications (C).** Not all portions of this subsystem have been specified at this time,

- **Electromagnetic Pulse (EMP) Hardening.** It does not appear that sufficient attention to quality control was reflected in the original Air Force estimate. Welds on the steel liners installed in the Safeguard ABM system for EMP purposes were found to be a problem requiring special inspection procedures. The MPS documents do not discuss the welds required on the steel liner installed in each shelter.

With the exception of construction issues and the missile decoy, these uncertainties are normal for advanced and complex weapons systems at this stage of development. If the earlier Air Force estimate of \$33.8 billion has not properly assessed the support required to accomplish the construction program, the estimate could be substantially low. An error in estimating the cost of individual protective shelters is greatly magnified because a minimum of 4,600 shelters is required. Similarly, inadequate consideration of resources required to support the construction effort will be magnified because of the remoteness of the proposed deployment area.

Notwithstanding these uncertainties, a comparison of the Air Force baseline estimate to OTA'S estimate has been made (see table 13). OTA estimates the total acquisition cost for the Air Force baseline, with 4,600 shelters, is \$37.2 billion (fiscal year 1980 dollars), and a total lifecycle cost of \$43.5 billion. As previously mentioned, the OTA estimate is \$3.5 billion greater than the 1980 baseline estimate developed by the Air Force. This differential includes:

- \$06 billion in schedule contingency for missile RDT&E,
- \$0.7 billion for engineering changes in system components,
- \$0.6 billion in construction costs primarily associated with increased life support costs,
- \$0.7 billion in A&CO costs reflecting military pay for the Air Force personnel involved in this activity,
- \$0.9 billion in other adjustments.

As indicated in table 13, the Air Force has not budgeted costs for the MX program for program management and its Site Activation Task Force,

### Cost and Schedule of Expanding the MX/MPS

As noted above, the proposed 4,600-shelter system represents a baseline scenario. How-

**Table 13.—Comparison of Air Force and OTA Cost Estimates (billions of fiscal year 1980 dollars)**

	USAF baseline estimate	OTA baseline estimate
<b>Development</b>		
Missile related . . . . .	\$ 5.025	\$ 5.025
Base related . . . . .	2.839	2.837
Other . . . . .	.710	1.310
	<u>\$8.574</u>	<u>\$9.172</u>
<b>Investment</b>		
Nonrecurring production . . . .	\$ 1.110	\$ 1.110
Equipment procurement		
Missile system . . . . .	4.990	5.226
Transporter/vehicles . . . . .	1.634	1.634
Decoy . . . . .	2.321	2.321
C <sup>3</sup> . . . . .	0.915	0.915
Ground power . . . . .	0.542	0.756
Physical security . . . . .	0.335	0.335
Support equipment . . . . .	1.692	1.692
Aircraft procurement . . . . .	0.350	0.439
Total equipment & spares	<u>\$12.779</u>	<u>\$13.320</u>
Engineering change order . . .	\$ -	\$0.666
Facilities construction . . . . .	10.035	10.649
Assembly and checkout . . . . .	1.318	1.995
Program management . . . . .		0.222
Site activation task force . . . .		0.037
	<u>\$25.242</u>	<u>\$27.999</u>
<b>Operating and support</b>		
Replenishment spares . . . . .	\$ 0.647	\$0.647
System modifications . . . . .	0.187	0.234
Depot maintenance . . . . .	0.227	0.227
Operations and maintenance . .	1.480	1.611
Military personnel . . . . .	2.077	2.077
Civilian personnel . . . . .	0.410	0.410
Training . . . . .	0.192	0.192
Other . . . . .	0.910	0.910
	<u>\$6.130</u>	<u>\$6.308</u>
Total lifecycle cost . . . . .	<u>\$39.946</u>	<u>\$43.479</u>

SOURCE Office of Technology Assessment

ever, MPS basing might require as many as 8,250 shelters by 1990 and 12,500 shelters by 1995 in response to an expanded Soviet threat. The environmental impacts of such systems would, of course, be substantially greater than those of the baseline.

If we assume, as our projections suggest, a need for 8,250 shelters in 1990 and 12,500 in 1995, all resource requirements would change dramatically. OTA has calculated the additional resource requirements, and has estimated the gross changes that would be required in the construction schedule and work force. Table 14 indicates the land use requirements associated with these scenarios.

Under a high-growth scenario the construction work force and population projections also would increase dramatically.

If it becomes necessary to expand the system by building these additional shelters and missiles to keep up with an expanded Soviet threat, there would be a significant impact on cost and schedule for the MPS system. In light of projections for Soviet warhead buildup, we estimate costs for an MPS expansion under the following assumptions:

- a total of 8,250 shelters can be deployed in the Southwest by 1990, retaining the ratio of one missile to 23 shelters and 1 mile spacing;
- a total of 12,500 shelters can be deployed by 1995 in the Southwest, retaining the ratio of one missile to 23 shelters and 1 mile spacing; and

- presently planned clusters are not back-filled in order to enhance survivability.

It seems possible to achieve the first goal, 8,250 shelters in operation by 1990, provided there are no serious missile or site development problems, and that a decision to proceed is made in the near future. A shelter completion rate of approximately 2,000 per year would be required. This rate represents about a two-thirds increase in the presently planned construction rate (approximately 1,200 per year). As in the baseline case of 4,600 shelters, however, schedule slippage is likely. An expanded program schedule would also be in jeopardy unless funding and authority mechanisms are provided so that the required resources can be programed and marshaled for use when required.

While OTA does not have the information available to detail all resource requirements for the expanded program, no resource constraints (construction materials, equipment, or skilled personnel) are anticipated provided that sufficient leadtime is available between the decision to undertake the program and peak construction periods. The Nevada Power Co., for example, cannot presently meet peak demands for electric power and has existing purchase agreements with outside utilities. Long-term agreements with the company would be required if commercial power is to be used to support the construction and operations phases of the MPS program as planned. Other such commitments would be needed

**Table 14.—Land Use Requirements**

	Acres		Acres		Acres	
Shelters . . . . .	11,040	(17)	19,872	(31)	29,808	(46)
Roads . . . . .	74,824	(117)	134,683	(210) <sup>b</sup>	202,024	(315)
Operating						
Bases and support . . . . .	51,456	(80)	92,620	(144)	138,931	(217)
Direct lands . . . . .	137,320	(214)	246,176	(386)	369,264	(576)
Potential impact zone <sup>b</sup> . . . . .	2,560,000	(4,000)	4,608,000	(7,200)	12,521,738	(19,565)
Numbers of shelters . . . . .		4,600		8,250		12,500

<sup>a</sup>Does not assume backfill

<sup>b</sup>This figure is based on the 0.25 mile disturbance zone discussed on page 70 and represents both the potential arid lands impact zone and an approximation of the land area which might be subject to restricted use under an expanded PLU security program

SOURCE: Office of Technology Assessment

Referring to table 16, it can be seen that it will cost about \$20 billion more to deploy and operate 8,250 shelters, and about \$40 billion more for 12,500 than the presently planned 4,600 shelters. The estimate assumes that a third operating base (OB) will be required for the expanded system, and, in addition, that the OB will have the associated missile assembly and contractor support facilities for the 12,500 shelter option.

Costs were obtained by scaling up the baseline cost estimate for 4,600 shelters to the year 2000. The additional 5 years were considered so that 10 full years of operations for the 12,500 shelter option could be included.

Costs were also estimated for the cases in which additional shelters would be backfilled into the original clusters (by filling in the gaps of the original hexagonal-array deployment). This approach would reduce connector costs

**Table 16.—Lifecycle Cost of 4,600, 8,250, and 12,500 Shelters to the Year 2005 (billions of fiscal year 1980 dollars)**

	Number of shelters		
	4,600	8,250	12,500
<b>Development</b>			
Missile . . . . .	\$ 5.0	\$ 5.0	\$ 5.0
B a s i n g . . . . .	2.9	3.0	3.1
Other . . . . .	1.3	1.4	1.5
<b>Total . . . . .</b>	<b>\$ 9.2</b>	<b>\$ 9.4</b>	<b>\$ 9.6</b>
<b>Investment</b>			
Missile . . . . .	\$ 4.3	\$ 6.1	\$ 8.1
Cannister/launcher . . . . .	0.9	1.5	2.2
Transporter . . . . .	1.4	2.4	3.6
Construction/activation . . . . .	12.6	19.9	28.5
Other . . . . .	8.8	13.7	19.1
<b>Total . . . . .</b>	<b>\$28.0</b>	<b>\$43.6</b>	<b>\$61.5</b>
<b>Operating and support costs</b>			
Annual . . . . .	\$ 0.469	\$ 0.719	\$ 0.969
<b>Lifecycle costs</b>			
To FOC . . . . .	\$38.6	\$55.2	\$77.7
To the year 2000 . . . . .	\$43.5	\$62.4	\$82.6
To the year 2005 . . . . .	\$45.7	\$66.0	\$87.4
<b>Operating personnel</b>			
Military personnel . . . . .	10,900	16,450	22,000
Civilian personnel . . . . .	1,700	2,600	3,500
<b>Total . . . . .</b>	<b>12,600</b>	<b>19,050</b>	<b>25,500</b>

(roads, powerlines, etc.) and other nonshelter facilities, for the first 2,300 additional shelters. Afterwards, entire additional clusters would need to be built to accommodate the additional shelters. For these cases, a 10-year lifecycle cost savings of \$4.5 billion for the 8,250 shelter option and \$5.3 billion for the 12,500 shelter option was estimated.

Operating personnel requirements were based on a detailed analysis of personnel for the 4,600 shelter option provided by the Air Force and scaled for the expanded options.

This method provides reasonable cost estimates for comparative purposes. Time and information available for the estimate did not, however, allow for a full investigation of the impact of the increased requirements for scarce resources (some missile materials and propellants) or the potential impacts of economics or diseconomies of scale on the construction program. Final estimates, therefore contain a significant degree of uncertainty and further analysis is required before actual funding levels can be determined with precision.

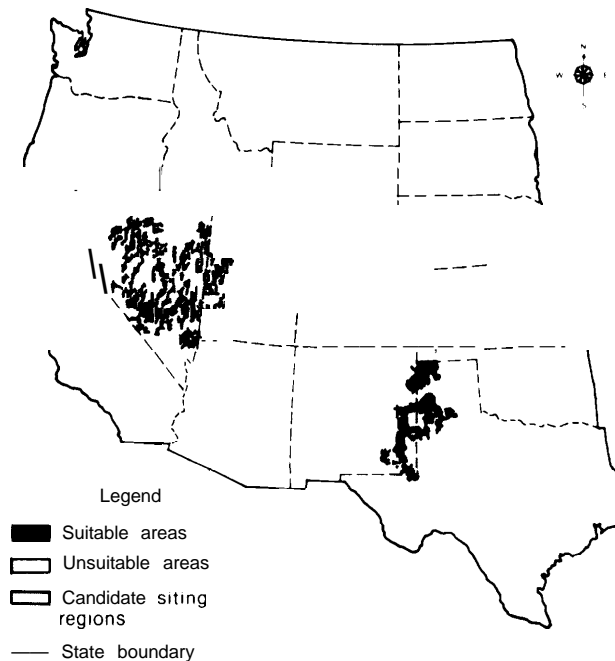
### Split Basing

The proposed MX/MPS basing plan calls for the location of all shelters and support facilities over a broad geographic area. Deployment clusters would be located in valleys of the Great Basin and would be separated by the mountain ranges which separate the valleys; but the system would otherwise be operationally contiguous.

The "split basing" option would be similar in all functional respects except for the fact that a large area of nondeployment land would separate the operational deployment areas. In both cases the same number of missiles, shelters, and land area would be involved, and in both cases there would be two operating bases. Figure 44 shows the geographic distribution of the proposed Air Force split basing alternative.

From an operational standpoint, there are no significant differences between contiguous basing and split basing. Both alternatives re-

Figure 44.—Proposed Split Basing Deployment Areas



SOURCE A F /DEIS

quire the same number of missiles, shelters, and operating bases; and both have the same functional requirements for command, control, communications, security, and support.

From the standpoint of the costs of construction and the environmental impacts, however, there are several notable differences,

First, construction of split basing would cost approximately 10 percent more than the baseline, as there would be some necessary duplication in geotechnical investigations, in electronic and mechanical systems, in transportation and logistics, and some additional costs in land acquisition resulting from the need to negotiate easements or title for a larger percentage of private lands. (See table 17.)

Second, impacts on both the physical environment and the regional economy could be substantially different. Although the general nature of the impacts would be fundamentally the same as those resulting from the proposed basing option, specific impacts could differ

**Table 17.—Air Force Estimates of Additional Split Basing Costs (in millions of fiscal year 1980 dollars)**

<i>RDT&amp;E</i> .....		\$ 121
Geotechnical .....	\$ 63	
Electronics .....	27	
Mechanical .....	16	
Deployment .....	5	
Procurement .....		2,171
Airborne lunch control .....	59	
Helicopters .....	29	
Initial spares .....	10	
Mechanical .....	28	
Electronics .....	157	
Logistics .....	63	
Initial spares .....		
Deployment .....	\$1,761	
(A&CO and training)		
Milton .....		\$1,183
Real estate .....	\$ 527	
Road network .....	53	
Remote surveillance .....	11	
Construction O&S .....	32	
Training facilities .....	54	
Design funds .....	41	
Designated assembly area and contractor support area .....	465	
Total .....		\$3,475

SOURCE US Air Force

significantly based on the site-specific characteristics of the impact regions.

In general split basing would mitigate the impacts on the physical environment by dispersing the direct impacts, and could have the effect of avoiding impacts on certain areas altogether, or avoiding critical thresholds in particular instances. In regard to socioeconomic impacts, split basing would complicate the issues of land-acquisition and integrated planning, but offers the possibility that impact levels would be within the management capabilities of more communities, and thus result in more beneficial impacts and fewer boomtown conditions.

In the case of socioeconomic impacts there may be a third qualitatively different type of impact associated with split basing. In addition to the reduction of adverse impacts noted, and cases in which the reduction in impacts effectively eliminates the adverse impacts (e.g., a case in which the reduced growth level re-

sulted not only in a reduction of the level of overcrowding in schools, but reduction to a level that presented no over-crowding), split basing could transform negative impacts into positive impacts in instances where the level of new growth was within the carrying capacity of the existing social infrastructure.

Thus, not only would the level of negative impacts be reduced, but in many small communities, and most likely in the larger towns close to the operating base areas, negative impacts could become positive impacts,

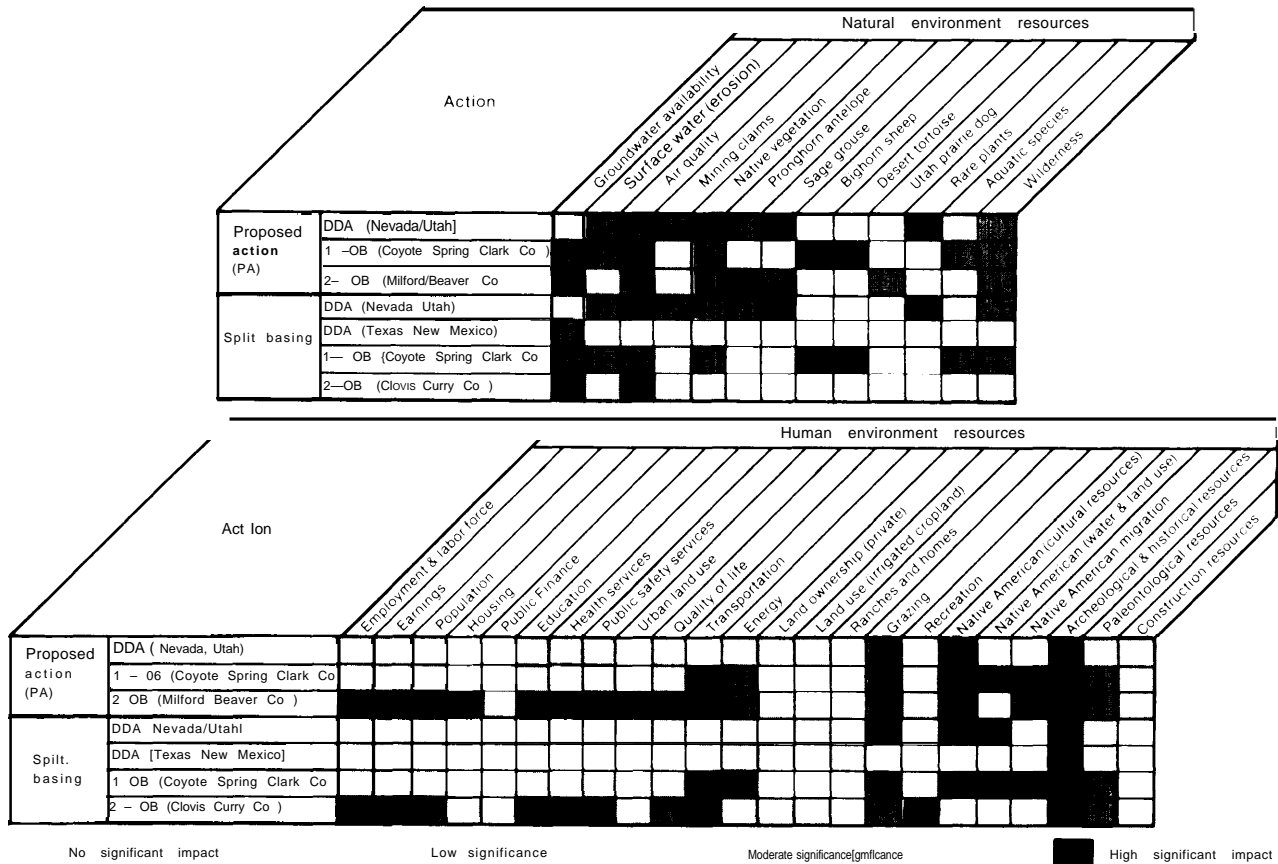
### Physical Impacts

Based on the Air Force resource analysis relevant to the split basing option, it is apparent that split basing would have significantly less impact on wildlife and the physical environment than the baseline option. \* (See fig. 45.)

There are, however, other complicating factors regarding the proposed split basing option. In the Great Basin of Nevada and Utah, virtually all of the land is owned by the Federal Government, and the dominant economic activities (ranching and mining) are subject to lease and permit authorities. In the split basing deployment area of New Mexico and west Texas, 95 percent of the land is in private ownership and is used primarily for crop production and livestock. The differences between use of rangeland and cropland, and the differences between private and public ownership of the land, raise potentially significant questions. First, as noted above, the use of croplands would take a greater amount of agricultural land directly out of production; but, the higher productive capacity of the land would also facilitate restoration of the impacted areas. As a result, considerably less land would be likely to be lost from productivity.

\*See *DEIS matrix, and 36 p 1-1*, including vegetation, habitat, and protected and endangered species. Additionally, the Air Force has indicated that impacts on the characteristics of the pristine environment, archaeological and historical sites, local populations, and economic adjustment, would also be reduced under the split basing option.

**Figure 45.—Summary Comparison of LongTerm Impact Significance Between the Proposed Action and Split Basing<sup>ab</sup>**



<sup>a</sup>While there may be an overall estimate of no impact or low impact when considering the DDA region as a whole it must be recognized that during short term Construction activities specific areas or communities within or near the DDA could be significantly impacted.  
<sup>b</sup>The reduction in DDA size for Nevada/Utah under split basing does not necessarily change the significance of impact on a specific resource. Many impacts occur in a limited geographic area which is included in both the full and split deployment DDAs, or are specific to the OB suitability zone.

SOURCE U S Air Force/DEIS

Second, the legal basis for conducting necessary PLU activities is more clearly defined in relation to privately owned lands than it is in relation to public lands. In the case of private lands, it would be necessary to negotiate easements to allow for access to shelters and for periodic "security sweeps" and investigations; but the contractual basis for such arrangements are unambiguous. In the case of the public lands the necessity of periodic sweeps raises legal questions regarding possible restrictions on public use or access to public lands.

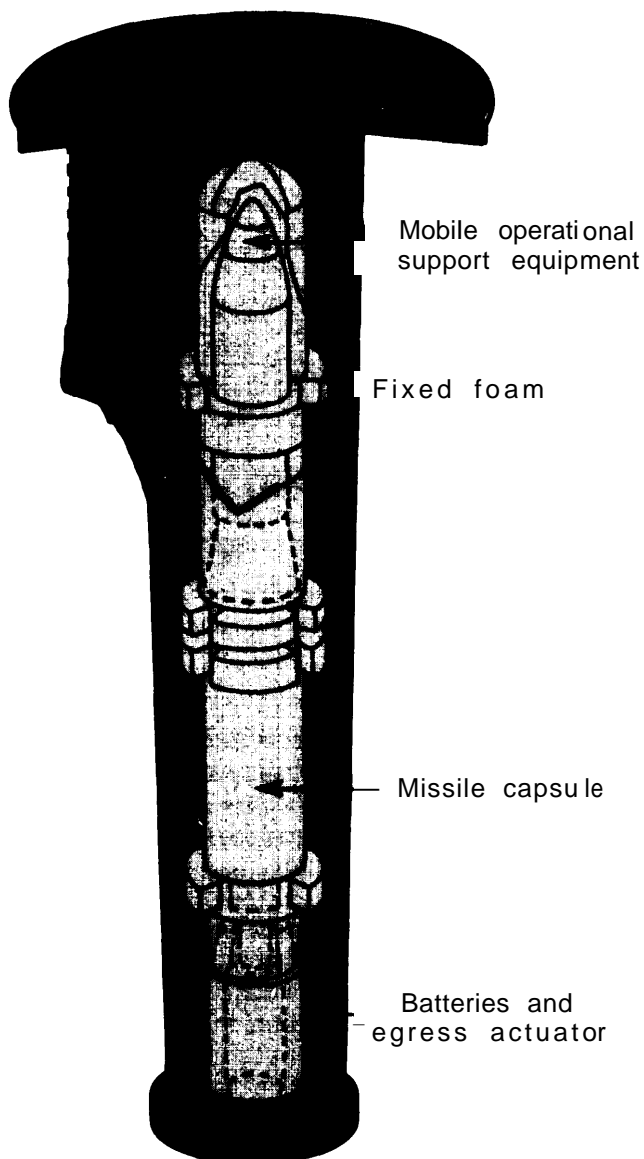
Finally, in terms of land acquisition, it is uncertain whether the political process of land withdrawals necessary for use of the public lands might be more or less cumbersome than the process of individual negotiations with private landholders. It does appear likely, however, that the process of acquiring lands through both the congressional land withdrawal process and private negotiations, would be more cumbersome than reliance on Federal lands alone.



## VERTICAL SHELTERS

An alternative to employing horizontal shelters for MPS is to house the missiles in more conventional vertical shelters. (See fig. 46. ) Aside from the difference between whether the missile is stored horizontally and erected to vertical for launch, or stored vertically in a ready launch position, there are

Figure 46.—Vertical Shelter



SOURCE: U.S. Air Force

several important issues. One issue, and perhaps the primary one, is shelter hardness. Pound for pound of concrete, vertical shelters are more resistant (harder) to the effects of nearby nuclear detonations. Shelter response is easier to analyze and we have more experience in testing and building vertical shelters. A second important issue is the ease and speed of missile movement, particularly the insertion and removal times of the missile at the shelter. A horizontal shelter allows a simple roll transfer of the cargo between the transporter and the shelter; transfer for a vertical shelter requires the additional transporter operation of erecting the missile to vertical for insertion and removal from the shelter. A third issue, arms control monitoring, is discussed below.

### Shelter Hardness

There are several damage mechanisms to a missile from a nuclear detonation. These mechanisms are airblast, ground shock, electromagnetic pulse, radiation, and thermal effects. Airblast results from the intense compression of air at the explosion, that propagates away from the source as a supersonic shock wave. An airblast results in overpressure destruction, and it is particularly severe on aboveground objects (such as the shelter door of a *horizontal* shelter) that must withstand the reflected loads of the incident shock front. For a vertical shelter, with a shelter door that is flush with the surface, there are no reflected loads, and door requirements are far less severe than for the horizontal shelter. In addition, ovaling of the horizontal tube is a more serious problem than is the compression on the vertical shelter.

The task of testing and modeling for dynamic (wind) pressure is also more difficult for horizontal than for vertical shelters. Because the dynamic flowfield for the horizontal case is sufficiently complex, adequate simulations are difficult. The result is a less complete capability to test and validate a horizontal shelter design. Nevertheless, it is believed that

with a sufficiently comprehensive validation program, confidence in horizontal shelter hardness can be adequately established.

Ground motions result from the "air-slap" of the shock front hitting the ground as well as propagation through the earth of upstream coupled energy. The damage mechanism of dominant concern is the missile coming up against and forcibly hitting the shelter wall from the inside, as the shelter moves with the ground. To design for this in a simple MPS shelter, the missile is given enough space inside the shelter to move before coming up against the shelter wall. This space between missile and shelter is called rattle space, and for shelters several thousand feet distant from a 1-MT nuclear detonation, typical rattle space is tens of inches. Since at ranges of interest ground shock motions are typically larger in the vertical than horizontal direction, vertical shelters require less concrete than do horizontal shelters, since the inside diameter of the shelter does not need to be as large. In addition, the missile is constructed to be more resilient to motions along its length than transverse to it.

For radiation and thermal effects, since the flux direction on the surface is along the ground, more stringent requirements for the horizontal shelter door are necessary than for the surface-flush vertical door. Electromagnetic pulse effects do not appear to discriminate strongly between horizontal and vertical shelters, although the greater radiation attenuation afforded by the vertical shelter would ease hardness requirements for radiation-induced electromagnetic pulse,

In summary, it appears that building a survivable horizontal shelter is a more demanding task than would be the vertical shelter, and vertical shelters can be easily made more than 1,000 psi hard, whereas the design and hardness validation of a 600 psi horizontal shelter pushes state of the art engineering. Nevertheless, for an MPS system, this *hardness should be enough*. MPS does not rely on the shelter surviving a direct attack, but by surviving the effects of an attack on neighboring shelters. To the extent that a fractionated threat would

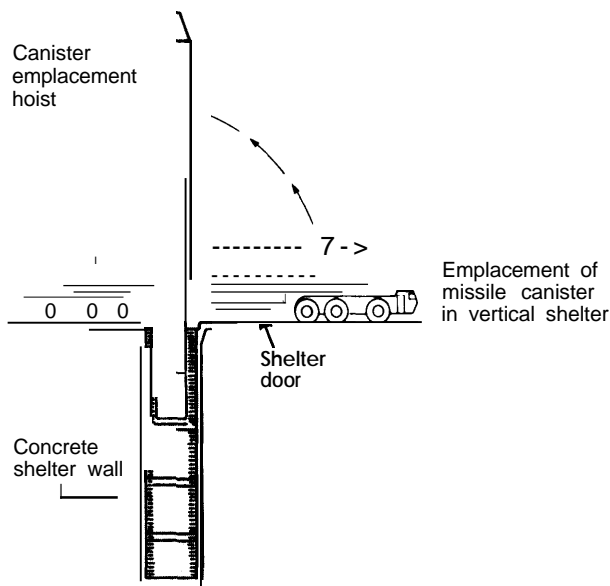
reduce warhead yield, consideration might be given to building a sufficiently hard vertical MPS, perhaps several thousand psi hard, in order to withstand the increased threat without building more shelters. Nevertheless, because shelter kill probabilities are exceedingly sensitive to missile accuracy, and Soviet missile accuracies are projected to continue to improve, hard vertical shelters still would not be likely to survive a direct attack. Therefore, shelter number requirements for vertical shelters might not be significantly different from horizontal shelters. (This question is more thoroughly addressed in the classified annex.)

Even though vertical shelters will be harder, the state of knowledge of electromagnetic pulse effects is not considered firm enough to allow shelter spacing for *any* shelter design much less than 5,000 ft, which is the current spacing for baseline horizontal shelter MPS. However, there exists the possibility that vertical shelters could be more densely "packed" in the same area (e. g., by backfilling) and would therefore require less land for the same number of shelters.

### Missile Mobility

For the Air Force baseline, it is stated that as a hedge against a loss of PLU, the missiles would have the capability of rapid relocation and an on-road hide-on-warning capability against SLBM attack. This reliance on missile mobility makes missile transfer timelines important to the choice between horizontal and vertical shelters. The relevant difference here is the time required for insertion and removal of the missile. Because the transporter for the vertical system must perform missile raising and lowering operations with a strongback, rather than the roll-transfer operation for the horizontal system, the transporters for the two systems are designed differently. (See fig. 47 for the transporter designs that have been studied.) Although a horizontal shelter transporter has not yet been constructed to test timelines, an operational vertical shelter emplacer has been constructed and tested at the Nevada Test Site (NT S). Remove and install

Figure 47.—Transporter for Vertical Shelter



SOURCE U S Air Force

timelines for horizontal and vertical systems based on these transporter designs and on the NTS field tests as shown in figure 48, The vertical system timelines are based on extrapolation of test data, such as increased automation, adding more hydraulic pumps for the strongback lift actuator, and so forth in order to optimize transfer time. Horizontal system timelines are based on the current baseline design. Using these two transporter designs and the test figures, emplacement and removal times are slightly under 5 minutes for the horizontal system, and somewhat over 22 minutes for the vertical system can be seen, It must be emphasized that these figures are based on given transporter designs; different timelines may be derived based on unfamiliar designs. Also, the figure for vertical emplacement is based only on design mechanical constraints. No consideration has been given to further constraints that may be imposed by explosives handling,

Based on these figures, relocation time for the vertical system is longer than for the horizontal system, due only to the transfer times. When adding travel times, relocation for the horizontal system is about 9 hours, and for the vertical system, 15 hours.

For hide-on-warning dash from the road, emplacement figures for the baseline horizontal are presented in figure 49 but none was available for the vertical. Because of the very tight timeline for the dash missile emplacement operation, it would necessarily take a very different vertical system transporter to satisfy the 2-minute insertion schedule needed to support an SLBM-timeline dash. Among the current conventional designs, only the horizontal system could support the SLBM dash.

## PLU

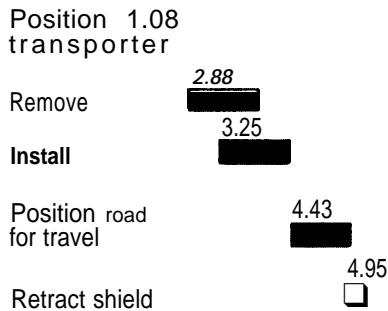
Because most of our detailed understanding of PLU has come only in the last several years, when the baseline system has been horizontal, it is difficult to say with confidence if PLU provides an adequate basis for preferring a horizontal or vertical shelter. We do not know as much about the signatures and countermeasures for the vertical system to make a reliable comparison. It is almost certain, however, that many of the countermeasures designed for the horizontal system will need to be modified or completely replaced for a vertical system. The mass simulator will probably be quite different. (An early design for a vertical simulator, called the "chimes," because it was composed of four vertical rods, may not be feasible because its vibrational modes are similar to the discarded T E L simulator concept; see pp. 97). Much PLU design work would have to be done to resolve these questions.

## costs

OTA estimated the cost of deploying the MX missile in vertical shelters in the Great Basin region of Nevada and Utah. The estimate assumes that, with the exception of shelter and transporter costs, the costs associated with vertical shelters are the same as the costs associated with horizontal shelters. Thus, the costs of the missile, C<sup>3</sup>, physical security, ground power, environmental control, support facilities, roads, and other support elements are considered to be independent of shelter design at least in total. Other ground rules include:

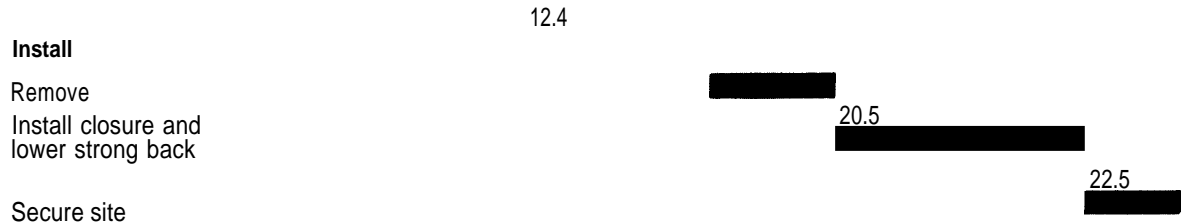
Figure 48.— Remove/Install Timelines for Horizontal and for Vertical Shelters

- Comparison — horizontal/vertical systems
  - Co-locatable mass simulator on site time
  - Horizontal
    - Potential timeline increase due to PLU (O = 8 rein)



- Vertical
  - Superficial PLU analysis performed

Alignment and stabilization = Closure removal and raise strong back -



SOURCE U S Air Force

- 4,600 shelters;
- 200 deployed missiles, one per cluster of 23 shelters;
- shelter spacing of about 5,000 ft;
- approximately 8,000 miles of roads; and
- IOC and FOC dates identical to MX/MPS in horizontal shelters.

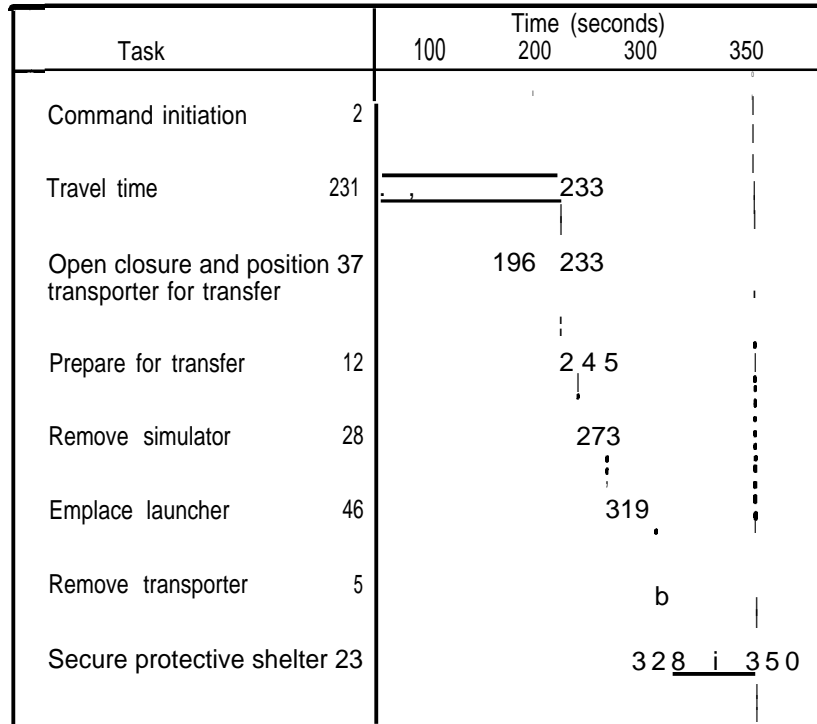
The total construction costs of 4,600 vertical and horizontal shelters are \$5.1 billion and \$6.3 billion respectively (in fiscal year 1980 dollars), a difference of \$1.2 billion. These costs were derived from the application of the Air Force DISPYIC model and cost inputs applicable to the horizontal shelter program (materials costs). Horizontal shelter costs were taken from material furnished by the Air Force.

The major differences between horizontal and vertical shelter costs result from different material requirements and construction costs. The following characteristics of the two types of shelters illustrate the reasons for the differences:

	Horizontal	Vertical
Length	171 ft	122 ft (deep)
Inside diameter	145 ft	131 ft
Wall thickness	21.0 inches	101 inches
Concrete	934 yd	254 yd
Rebarsteel	35 tons	15 tons
Liner steel	62 tons	16 tons
Miscellaneous steel	21 tons	4 tons

Thus, 4,600 horizontal shelters would require about 3.1 million cubic yards more con-

Figure 49.— Dash Timeline for Horizontal Shelter



SOURCE U S ir Force

rete than vertical shelters and about 380,000 tons more steel.

The transporter required for the vertical mode could be smaller than for the horizontal shelter (according to previous Air Force designs). This difference would result in a reduction in cost of about \$250 million to \$500 million for the 200 transporters required.

The horizontal shelter program is estimated to cost about \$43.5 billion to the year 2000. This estimate includes \$9.2 billion in development, \$28 billion for investment, and \$6.3 billion for operating and support costs. A vertical shelter program would be about \$1.5 billion less expensive, or a total of about \$42 billion for the lifecycle covering the deployment years (IOC to FOC) and 10 years of full-scale operations. Table 18 shows a breakdown of horizontal and vertical shelter lifecycle costs.

### Arms Control

There are few differences, in principal, between verifying an arms control agreement for a Vertical or horizontal MPS deployment, if the basing mode has been designed with arms control agreement verification measures. The key arms control agreement verification tasks associated with the basing mode include counting the number of missiles deployed and monitoring vertical shelter construction to ensure that the shelters are not actually new ICBM launchers.

So long as, at a minimum, the MX missile and its associated equipment are assembled in the open and left exposed for a period of days to permit accurate counting, the number of missiles and associated vehicles could be adequately verified. Deployment of the missiles and associated vehicles along a dedicated

**Table 18.—Lifecycle Costs for Horizontal and Vertical Shelters Deployed in Nevada-Utah**  
(billions of fiscal year 1980 dollars)

	Horizontal	Vertical
Number of missiles deployed	200	200
Number of shelters . . . . .	4,600	4,600
costs		
Development		
Missile . . . . .	\$ 5.0	\$ 5.0
Basing . . . . .	2.9	2.9
Other . . . . .	1.3	1.3
Total . . . . .	\$ 9.2	\$ 9.2
Investment		
Missile/cannister/launcher	\$ 5.2	\$ 5.2
Transport/vehicles . . . .	1.6	1.3
c' . . . . .	0.9	0.9
Other equipment . . . . .	5.5	5.5
Construction . . . . .	10.6	9.4
A&CO . . . . .	2.0	2.0
Other . . . . .	2.2	2.2
Total investment	\$ 28.0	\$ 26.5
Operating and support		
Procurement . . . . .	\$ 0.9	\$ 0.9
O&M . . . . .	1.8	1.8
Personnel . . . . .	2.5	2.5
T r a i n i n g	0.2	0.2
Other . . . . .	0.9	0.9
Total O&S	\$ 6.3	\$ 6.3
Lifecycle costs	\$ 43.5	\$ 42.0

SOURCE Office of Technology Assessment

transportation network to the deployment area would also permit counting of the missiles. These assembly and transportation procedures are common to the horizontal and vertical shelter deployments, indicating that these arms control monitoring aspects would appear to be the same.

However, the horizontal basing mode appears to some analysts to be a more desirable basing mode because it facilitates confirmation through direct observation that those missile shelters said to be empty of missiles do not in fact contain missiles. The Air Force baseline system relies on removable plugs in the shelters to permit such direct observation. The incremental value of such observation to arms control agreement verification is controversial.

## SOME PREVIOUS MX/MPS BASING MODES

### The Roadable Transporter-Erector-Launcher (TEL)

In the period between the start of full-scale engineering development in September 1979, through the spring of 1980, the missile and launcher were designed to be structurally integrated with the transporter, into a roadable vehicle called the T E L, for transporter-erector-launcher. (See fig. 50.) The entire TEL unit was to be placed in the protective shelter. On command to launch, the shelter door would open, the TEL would plow through any debris, erect the missile to a near vertical position, and launch the missile,

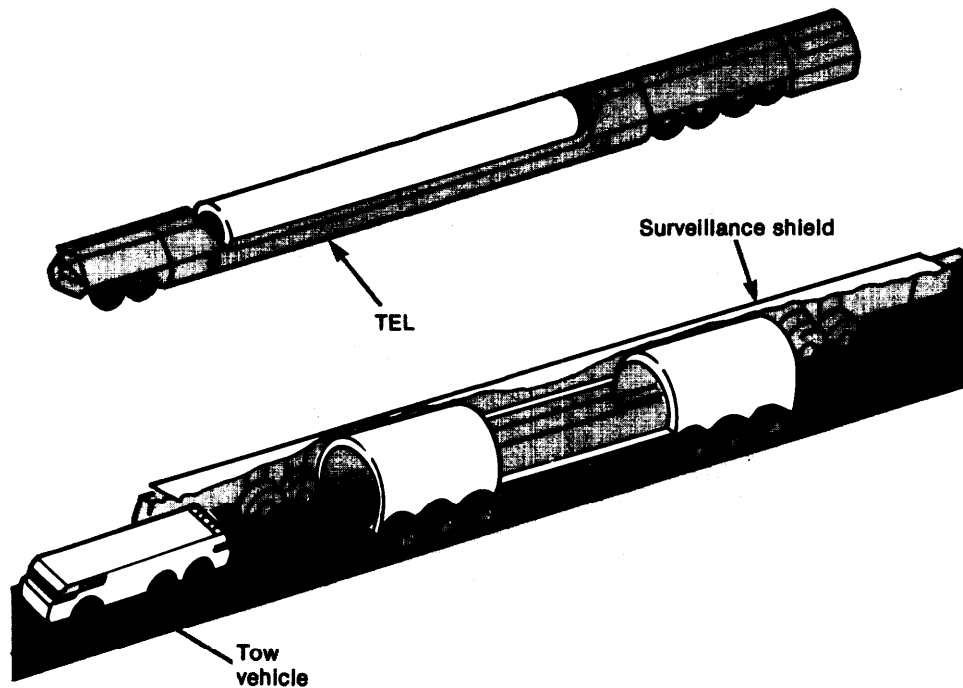
The TEL could exercise several mobility options. One mode, used for maintenance and rapid relocation, would have the TEL transported, and shielded under a towed, wheeled vehicle called the mobile surveillance shield.

The surveillance shield would visit every shelter, simulating a TEL insertion at each one except for the shelter where it actually deposits the TEL. This operation would be manned. Travel to all shelters was estimated to be about 12 hours, as in the current design.

A second mobility mode would permit a portion of the force to be on the road, under the surveillance shield. This manned hide-on-warning operation would respond to SLBM attack warning, and secure the TEL at the nearest shelter before the attacking warheads arrived. Like the first mode, this is similar to the presently designed capability,

The third mode of missile mobility was called the dash. Dash was to be an unmanned operation. Upon receipt of warning of an ICBM attack, the TEL would leave its shelter, unconcealed, and dash to another shelter

Figure 50.—Roadable Transporter- Erector.Launcher (TEL)



SOURCE U S Air Force

within the cluster. To be successful, this would have to be done within the 30-minute flight time of attacking ICBMS. Arranging the shelters in a closed loop would facilitate dashing into any other shelter in the cluster. This closed shelter arrangement with the dash operation led to the colloquial term, "MX Racetrack." This last mobile option could not be retained in the present "loading dock" design.

The most serious shortcoming of the TEL design is the difficulty of maintaining PLU, according to Air Force analysis. The TEL shelter is larger than the present shelter design by 2 ft in diameter, and in order to have the possibility of satisfying PLU, the shelter needed to be even further expanded to be able to house a credible TEL simulator and still support the dash capability. With the 16.5-ft inner diameter shelter of the TEL design as a constraint, all decoys studied by the Air Force had a poor signature match to the TEL. One design

used two rods inserted between the inner and outer diameters of the shelter to act as a missile simulator. However, it was learned that the different vibration modes of the rods, as well as other distinctive signatures, would be evident during transit, simulator insertion, and removal. These arguments are quantitatively plausible.

Concerning the three mobility options discussed above, the first two are similar to the loading dock arrangement. For the third mobility option, unmanned dash, transferring the TEL during an ICBM flight time would leave it exposed during its transit to a coordinated SLBM attack, since the TEL unit is not designed to survive such an attack. Typical hardness for such a vehicle would be in the range of 5 to 10 psi, which lies approximately at the 1 to 2 mile contour for an exploding SLBM warhead. If, as suspected, PLU had been broken and the enemy knew the shelter location of the

TEL, then it could be vulnerable to an SLBM attack during the dash operation.

Other than the transporter design, dash, the larger shelter, and the closed cluster layout, this MPS design is the same as the present baseline system

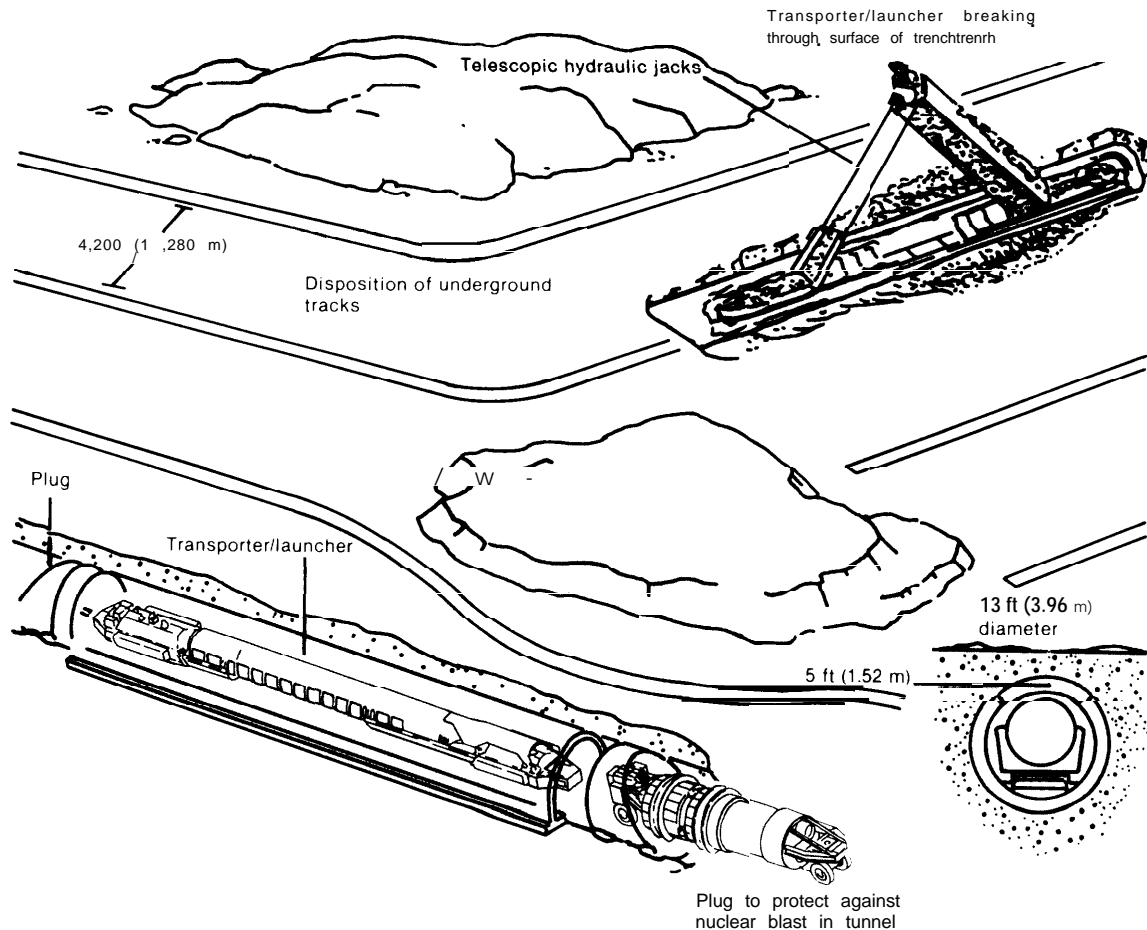
### The Trench

The trench was an even earlier design for basing the MX missile, before MX entered full-scale engineering development. In this mode, the missile, housed on an unmanned transporter and launcher, would reside in an underground concrete tunnel, out of public view,

(see fig. 51). As in multiple shelters, trench-basing the MX relied on keeping the missile location in the trench unknown to the attacker. The missile could randomly move in the trench as an additional PLU measure. In order to launch the missile, the transporter would break through the roof and erect the missile, preparatory to launching.

Several trenches have been designed for MX basing. Some trenches were continuously hardened, others were hardened in sections. Some trenches had single spurs in which the missile resided, and others had double spurs. Most trenches were designed with inside ribs to

Figure 51.—Trench Layout





accommodate blast plugs, designed to protect the missile (see fig. 52).

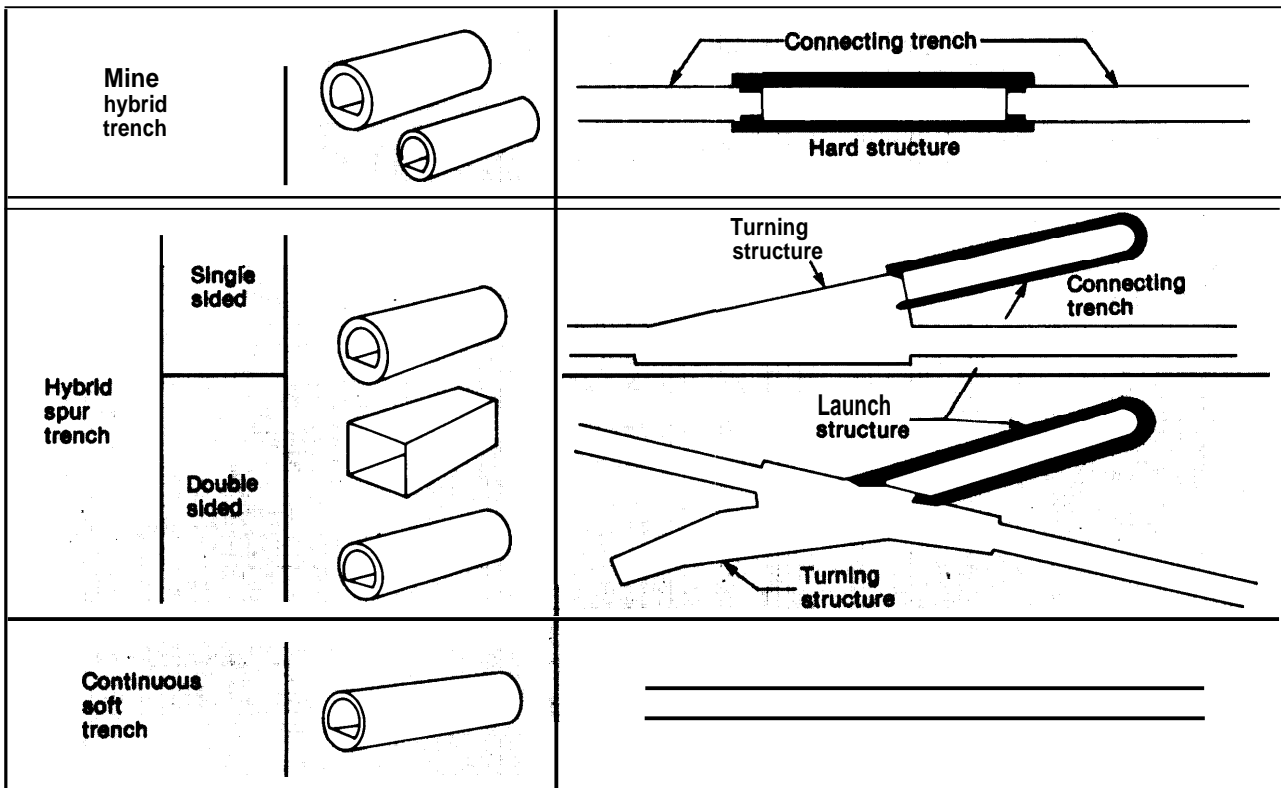
An early concern for trench basing was the possibility that the trench tube would serve as a shock wave guide. Specifically, the fear was that in an attack on the trench, the shock wave propagating down the tube (largely unattenuated due to the trench's one-dimensional geometry) would result in conditions capable of breaching the blast plug and destroying the missile beyond a range where it presumably would survive the internal airblast. Steps were taken in trench design to protect the missile from the in-trench shock wave propagation. This design included stationing the missile in tunnel spurs, so that the plug would experience the side-on overpressure and not the direct reflected shock.

A series of high-explosive blast tests on the trench was performed at Luke-Yuma in 1977-

78 (HAVE HOST, T-series), to investigate the above concepts for missile protection in the trench. Results of the tests indeed validated the blast plug concept on a half-scale trench test, and vividly showed the reflected shock venting at the plug. Even more significant, analyses by the Defense Nuclear Agency showed that even in the absence of blast plugs, hot air ablation of the tunnel walls (as well as other mechanisms) would attenuate the wave, such that the pressure impulse transferred to the plug would be approximately the same as if the trench were not even present.

A far more serious problem for the trench would have been PLU. Even though the missile would not be visible, its motion on the transporter, 5 ft underground, would not be difficult to detect. A large number of signatures would enable an observer to establish its location. (For a general discussion of these sig-

Figure 52.—MX Trench Concepts



SOURCE U S Air Force

natures, see the earlier section "Theory of MPS.") Therefore, missile-transporter simulators would be necessary to install, at which point system cost would be a deterring factor.

Moreover, security along the entire trench length probably also would be necessary, which would make the system less acceptable to the deployment region.

## MINUTEMAN MPS AND NORTHERN PLAINS BASING

One means proposed to protect the survivability of the Minuteman III component of the present land-based missile force is to redeploy these 550 missiles in an MPS system similar to that proposed for the MX deployment in Utah and Nevada. For this case, vertical shelters would be constructed in the existing Minuteman base areas. The existing Minuteman missiles would be modified so that they could be moved more easily among existing silos and the new ones. Like the MX/MPS basing mode, survivability would be sought by constructing more shelters than the Soviets had warheads available to target them. As a weapon, the Minuteman III could be improved to achieve MX design accuracy by backfitting the MX guidance unit. Such a force could use the existing Minuteman bases, public roads, and support infrastructure.

### Missile Modifications

A number of minor modifications would need to be made to the present Minuteman missile. To facilitate the increased handling of the missile, it would be placed in a canister. Attachment tabs, or their equivalent, would be installed on the stages to accommodate canisterization. The entire missile would be transported, unlike the present Minuteman missile, which moves the first three stages and the fourth stage, separately. In addition, several attachments in the missile that were originally built to accommodate vertical orientation of the missile, might need strengthening to support horizontal motion of the missile during transport. The Minuteman guidance unit would also need modification. None of the modifications to the Minuteman missile appears infeasible.

Most technical risks associated with an MX/MPS deployment would also be a factor for a Minuteman MPS deployment. Most notably, PLU would be likely to be as formidable a task as for MX. Also, demands on system expansion due to an increased Soviet threat would be similar to the case with MX,

Since the Minuteman missiles, roads, and infrastructure are already available it might seem possible that the cost and time needed to proceed with such a deployment could be significantly less than for MX baseline. To examine this hypothesis, Minuteman deployments, corresponding to the baseline MX/MPS deployment and for expanded threats were observed, and estimates were formed for cost and schedule. The cases are the following:

- **Case 1, Baseline.** Encapsulate existing 550 deployed Minuteman III missiles and 117 MM III currently in storage and modify for MPS and cold launch. Modify the existing 550 silos to accept the encapsulated missile. Build 5,250 new shelters, for a total deployment of 5,800 shelters, spaced a minimum of 1-mile apart. Deploy 5,250 decoys, and one transport for every two missiles. Reopen the MM III production line to replace missiles taken from storage. This mix of missiles and shelters would retain the same number of surviving Mark 12A warheads after a Soviet attack as the baseline MX/MPS system when deployed in conjunction with a planned Minuteman force of 350 MMIIIs and 450 MM IIS.
- **Case 2, Expanded 1990 Threat.** Deploy a cost optimum mix of Minuteman missiles and shelters, determined to be approximately 900 missiles and 10,400 shelters.

**Case 3, Expanded 1995 Threat.** Deploy a cost optimum mix of Minuteman missiles and shelters, determined to be approximately 1,100 missiles and 15,500 shelters for this threat level

### Cost and Schedule

Cost estimates are given for these three cases and the Air Force baseline system in table 19.

In case 1, it is estimated that 5,800 shelters with 667 MMIII missiles could be constructed in the Northern Minuteman Wings for about \$7 billion (fiscal year 80 dollars) less than the AF baseline system.

In case 2, corresponding to a 1990 Soviet threat level of 7,000 RV'S the cost estimate is \$534 billion for a system of 900 MMIII missiles and 10,400 shelters.

In case 3, corresponding to a 1995 Soviet threat level of 12,000 RV'S, the cost estimate is \$724 billion for a system of 1,100 MMIII missiles and 15,500 shelters.

The major cost drivers for these cases are mechanical systems (transporters and decoys,

primarily), construction, and assembly and checkout in the investment phase, Operations and maintenance and personnel costs drive the operating and support phase. MMIII missile R&D effort is minimal in relation to MX, assuming a maximum dependence on the existing Minuteman road network and C network, There would still need to be a substantial upgrading of the existing roads and new roads to the new shelters would be required.

If a decision to deploy Minuteman/MPS were made in the summer of 1981 it is still unlikely that IOC could be achieved before 1987.

Assuming a period of 18-30 months for site selection and land acquisition (including EIS preparation), it could be possible to start construction on new silos in late 1984 or early 1985 (see fig. 53) with a resultant IOC date of late 1986 or early 1987. At the same time other activities that would have to proceed in parallel would include:

- development of a missile decoy and PLU,
- development of a transporter,
- cold launch development,
- definition of additional C requirements,
- upgrading of existing roads and construction of new roads to withstand the weight and length of a new transporter.

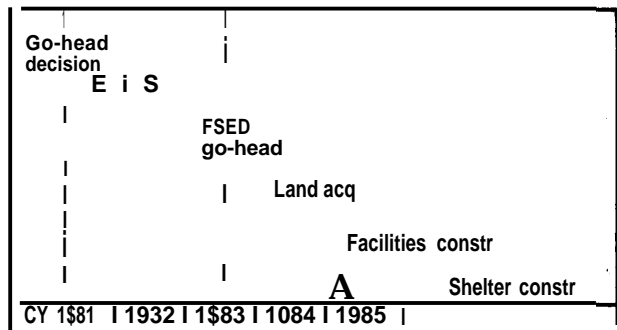
Schedule for FOC depends, in part, on peak construction rate. Assuming a peak construction rate of 2,000 shelters per year, by October 1986, FOC for Case 1 is projected to be 1989 or

**Table 19.—Minuteman MPS Costs**  
(billions of fiscal year 1980 dollars)

	Baseline	Expanded 1990 Threat	Expanded 1995 Threat
Missiles . . . . .	667	900	1,100
Shelters . . . . .	5,800	10,400	15,500
cost			
R&D . . . . .	\$ 2.5	\$ 2.5	\$ 2.5
Investment			
Nonrecurring . . . . .	1.4	1.4	1.4
Missile . . . . .	2.7	5.3	7.4
Equipment . . . . .	9.7	14.8	21.7
Aircraft . . . . .	0.5	0.5	0.5
Engineering change orders	0.6	1.1	1.5
Construction	10.4	15.7	21.7
Assembly and checkout . . . . .	2.4	4.1	5.9
Other . . . . .	0.3	0.3	0.3
Total investment	28.0	43.2	60.4
O&S to year 2,000.	5.9	7.7	9.5
Lifecycle cost . . . . .	36.4	53.4	72.4

SOURCE Office of Technology Assessment

**Figure 53.—Minuteman/MPS Schedule**



SOURCE Office of Technology Assessment

1990 Case 2 and Case 3 FOCs are projected by 1991 and 1994, respectively

An additional question which could be significant, but which has not been analyzed, regards the cost associated with upgrading roads to accommodate a deployment of MX missiles in the Northern Minuteman fields. In contrast

to the Minuteman transporter, which would weigh approximately 25,000 lb loaded, the loaded MX transporter would weigh close to 16 million lb. Modification and upgrading of roads to accommodate this transporter could affect cost, schedule, and socioeconomic impacts.

## CIVILIAN FATALITIES FROM A COUNTERFORCE MPS STRIKE

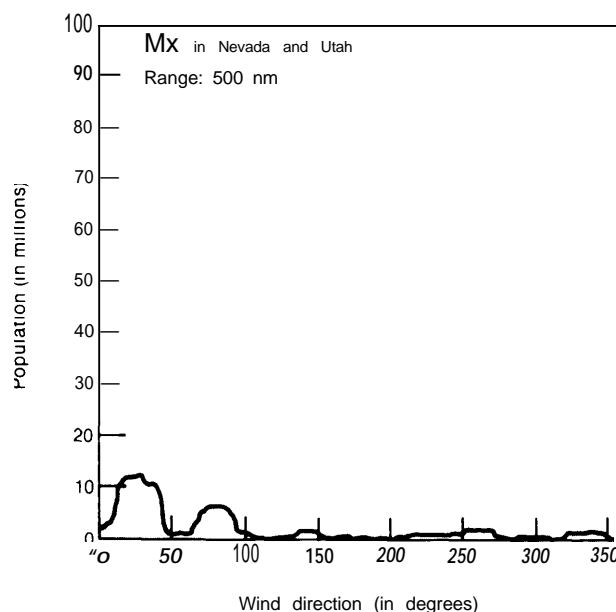
Interest has been expressed concerning the level of civilian fatalities resulting from a Soviet nuclear attack on an MPS-based MX deployment. Specifically, because the number of nuclear detonations in such an attack would run into the many thousands of megatons, there is concern that civilian deaths resulting from radiation fallout would be so large that it might be questionable if such an attack could in any sense be considered a "limited counterforce" strike.

In order to approach this problem, OTA obtained a series of calculations on resultant radiation doses over populated areas for a number of cases involving a nuclear strike on an MPS field. These computations are regarded only as representative and approximate at best. It is customary for such calculations to yield a wide range of results, and these are no different. The reason for this range is that results are strongly sensitive to a number of factors, including wind speed and direction, wind shear, burst height of the weapon, and the weapon's fission fraction. It is not unusual to see variations in calculated fatality levels of at least an order of magnitude for differing wind speeds. Furthermore, different computer codes for the same *physical circumstances* (winds, etc.) customarily yield results differing by a factor of 2 or 3. We have not attempted to resolve these differences, but have used a set of runs using the Weapons System Evaluation Group (WSEG) code as typical among different codes. In addition to these caveats, there are some additional limitations to these particular calculations. First, these computations rely on an urban-only population data base, consistin

of 140 million people. Therefore, total fatalities will be underestimated because fatalities in rural areas will not have been counted. Second, because the number of nuclear detonations would run into the many thousands, significant total doses depend on very small dose levels from the individual weapons. Because data at these small doses is scant, the value of any of these fallout models should be suspect.

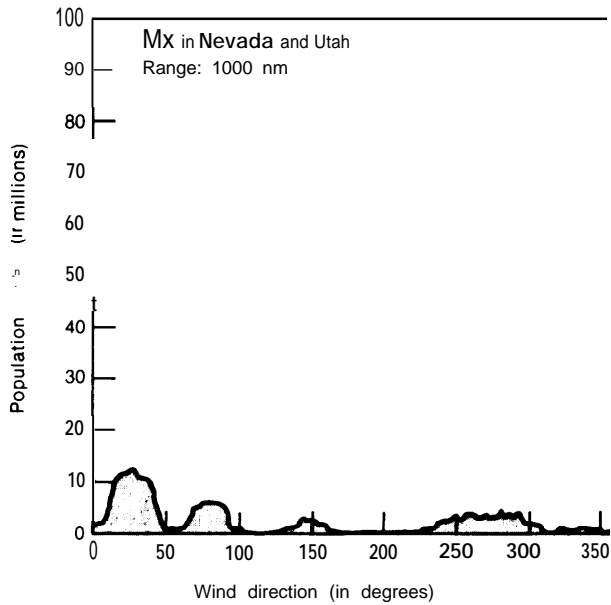
As an illustration of our population data base, we show in figs. 54 A-D the population in

**Figure 54A.—Population Subject to Fallout v. Wind Direction**



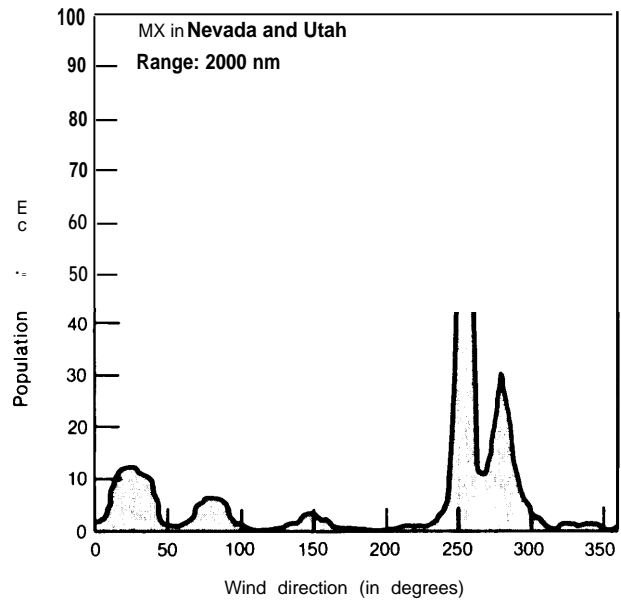
SOURCE: Lawrence Livermore Laboratory

**Figure 54B.—Population Subject to Fallout v. Wind Direction**



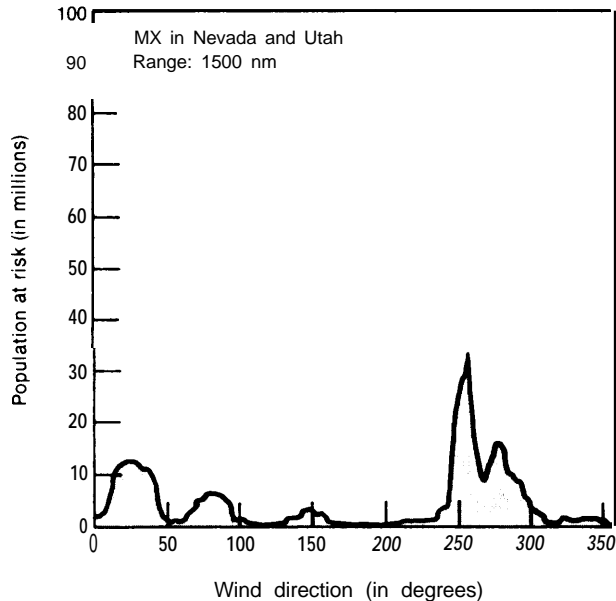
SOURCE: Lawrence Livermore Laboratory

**Figure 54D.—Population Subject to Fallout v. Wind Direction**



SOURCE: Lawrence Livermore Laboratory

**Figure 54C.—Population Subject to Fallout v. Wind Direction**

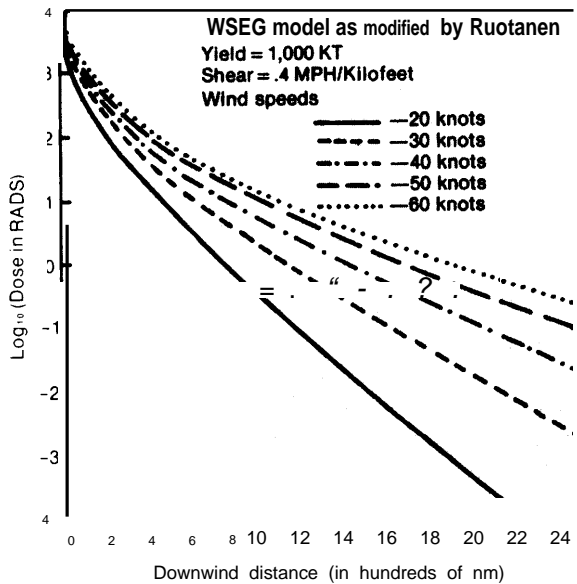


SOURCE: Lawrence Livermore Laboratory

the path of radiation fallout versus wind direction, at distances from the MPS fields of 500, 1,000, 1,500, and 2,000 nautical miles. In these charts, a wind direction of 00 is from north to south. Similarly, a wind direction of 1800 is from south to north. A wind direction of 2700 points due east. In fig. 54A, the peak at 250 represents the Los Angeles area, 800 corresponds to the San Francisco Bay area, and so forth.

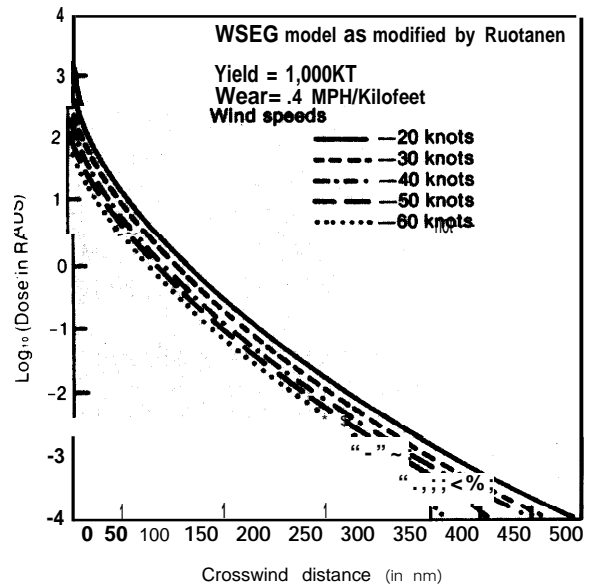
To determine the range of lethal fallout, and therefore the magnitude of civilian radiation fatalities, figure 55 shows the dose, in rads, resulting from the detonation of a 1-MT weapon with downwind distance. These doses are plotted for a range of possible wind speeds, from 20 knots to 60 knots. For example, with 20 knot winds, the one rad contour would extend to about 800 nautical miles (for a single 1-MT weapon). This contour would extend to about 1,400 nautical miles (or 1,600 statute miles) with 40 knot winds, and so forth. The 10- to 20-km altitude is the region where the mushroom cloud stabilizes and carries the bulk of the

Figure 55.— Downwind Distance v. Total Dose



SOURCE Lawrence Livermore Laboratory

Figure 56.— Crosswind Distance v. Total Dose



SOURCE Lawrence Livermore Laboratory

radioactive fallout. A survey of wind conditions for the proposed MPS deployment area showed wind speeds at these altitudes that averaged 30 to 40 knots, depending on season, with a typical wind direction of 2500 to 290 i.e., from the west-southwest to west-northwest. Finally, figure 56 shows the maximum width of radiation dose contours with differing windspeed for a given wind shear. (This width occurs at approximately half of the downwind range for a given dose.)

Civilian fatalities will depend on the prevailing winds, as well as the degree of protection taken by the populace. The 50-percent fatality level occurs at about 450 rads and the 90-percent fatality level occurs at about 600 rads. (For our purposes, we use the rad and the rem, for roentgen-equivalent man, inter Changeably. ) Second, the relation between exposed radiation dose and the actual absorbed dose depends on the degree of protection afforded the population at the time of attack. This is commonly expressed as a protection factor, which is a direct proportionality between total dose absorbed for a given state of protection (e. g., in the basement of a house) and the dose

collected without any protection, such as out in the open. Typical protection factors vary between one and 20 (see The Effects of Nuclear Weapons, 3rd ed., Samuel Glasstone and Philip Dolan; Table 9.1 20)

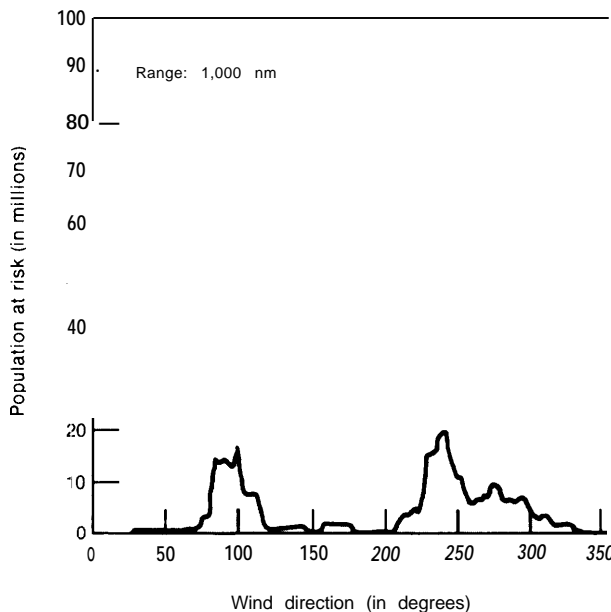
An attack on MX in Nevada and Utah might involve the detonations of 4,600 1-MT weapons, spread over about 20,000 mi<sup>2</sup>. Based on these graphs, total doses of 500 to 2,000 rads for such a nuclear attack, corresponding to fatal doses for a protection factor of 1 to 4, might occur at a range of 500 to perhaps 1,500 nautical miles from the origin of the attack, and depending largely on wind speed. Going back to figures 54 A, B, and C, depending on wind direction as well as wind speed and population protection, civilian fatalities could range from less than 1 million to more than 20 million. For typical winds in a west or northwest direction, fatalities run from less than 5 million for a 500 nautical mile lethal range, up to 20 million to 30 million corresponding to our high lethal range of 1,500 nautical miles.

It is important to note that these figures indicate the expected fatalities due to an attack

on the MX fields alone. However, it seems probable that a Soviet attack on MX would be likely to include Minuteman and Titan fields, strategic bomber bases and submarines in port. Because these existing targets are distributed over a large area the *added* fallout related fatalities due to the additional targets in the MPS fields would have a likely range from less than 1 million to 5 million. Total fatalities for this limited counterforce attack have been estimated to range from 25 million to 50 million people

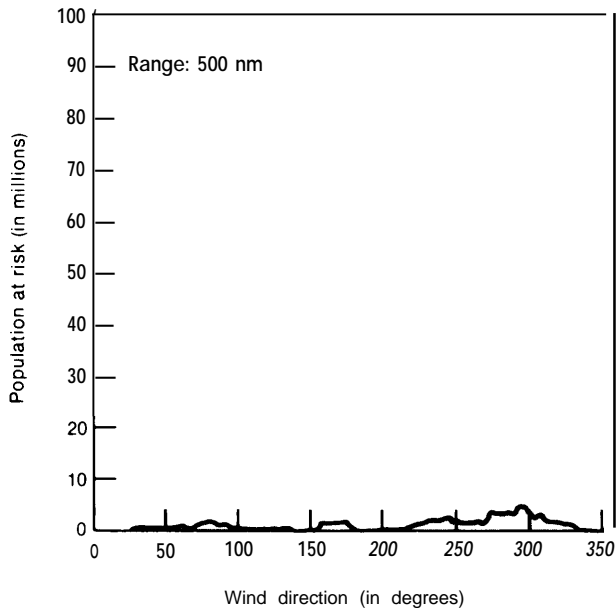
For an MPS deployment in Northern Texas and New Mexico, corresponding graphs of population at risk are shown in figures 57A-D. Windspeed and direction, for this area at relevant altitudes average 35 to 45 knots, and from the west, 2750 - 2800. With these winds, a nuclear attack might result in fatalities of 10 million to 20 million; however even a normal shift of wind direction could result in fatalities of well over 40 million for an attack on MX/MPS alone

**Figure 57B.—MX in Texas and New Mexico: Population Subject to Fallout v. Wind Direction**



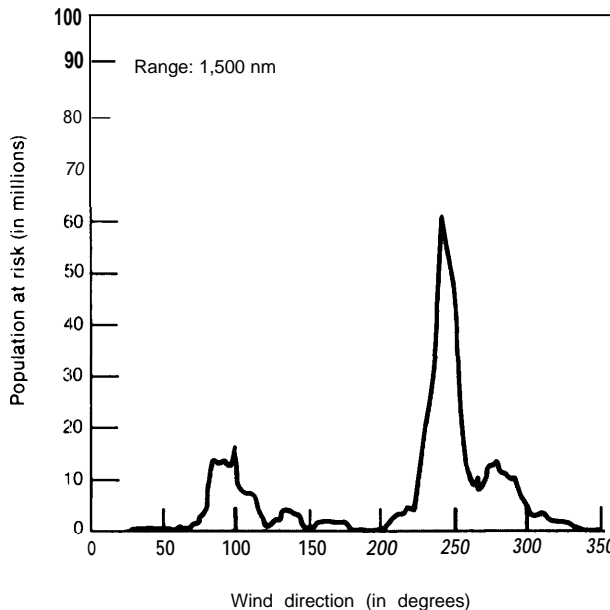
SOURCE Lawrence Livermore Laboratory

**Figure 57A.—MX in Texas and New Mexico: Population Subject to Fallout v. Wind Direction**



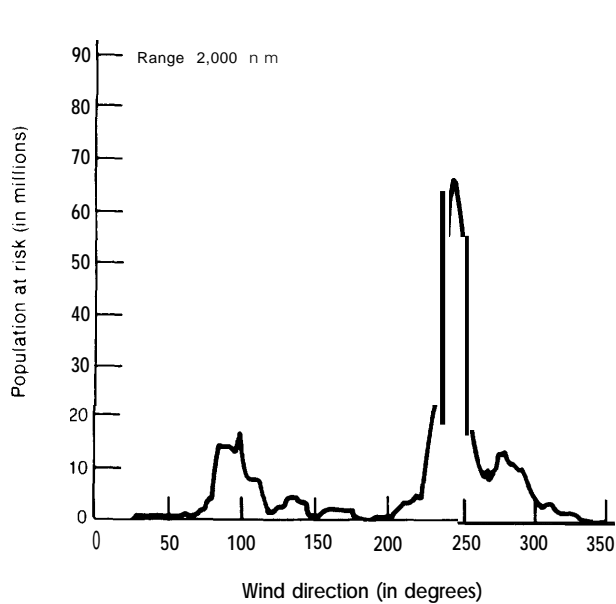
SOURCE Lawrence Livermore Laboratory

**Figure 57C.—MX in Texas and New Mexico: Population Subject to Fallout v. Wind Direction**



SOURCE Lawrence Livermore Laboratory

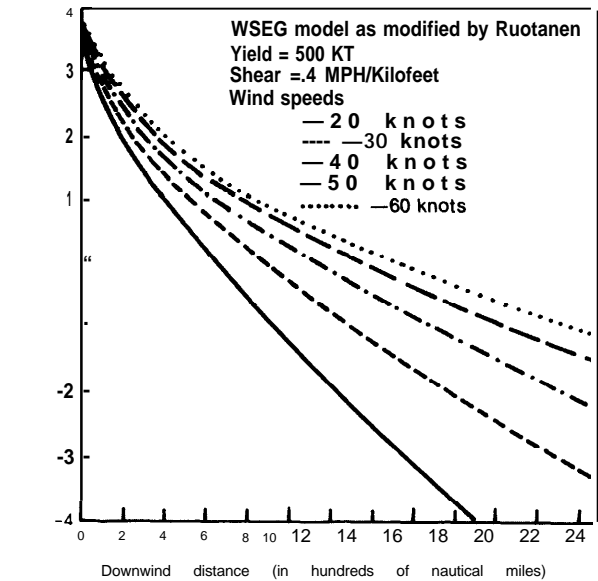
**Figure 57D.—MX in Texas and New Mexico: Population Subject to Fallout v. Wind Direction**



SOURCE Lawrence Livermore Laboratory

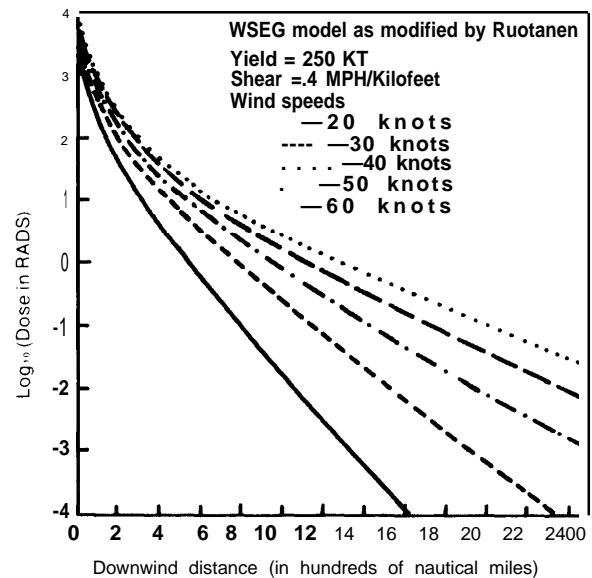
Results on civilian fatalities would also depend in part on the Soviet responses to MPS. If, for example, the Soviets responded by building more missiles, each carrying the same warhead yields as before, then the resulting radiation doses would go up proportionately. If however, the Soviets respond by fractionating their warheads, i.e., increasing the numbers of warheads with diminished individual yields, then total radiation dose would most likely go down, and not up. This decrease occurs for two reasons. First, fractionation customarily reduces total yield, resulting in less radioactive byproduct of the weapon. Secondly, a lower yield weapon results in a slightly lower altitude for the radioactive mushroom cloud, and hence less fallout range. This distinction can be seen quantitatively by comparing the one megaton case in figure 55 with the 500 and 250 kT cases shown in figures 58A&B.

**Figure 58A.—Downwind Distance v. Total Dose—500 KT**



SOURCE Lawrence Livermore Laboratory

**Figure 58B.—Downwind Distance v. Total Dose—250 KT**



SOURCE Lawrence Livermore Laboratory



## **Chapter 3**

# **BALLISTIC MISSILE DEFENSE**

# Chapter 3.—BALLISTIC MISSILE DEFENSE

	Page
Overview . . . . .	111
Technical Possibilities for BMD . . . . .	111
LoADS with MPS Basing. . . . .	112
The Overlay and Layered Defense of Silo-Based MX. . . . .	113
Other BMD Concepts . . . . .	113
The ABM Treaty . . . . .	113
Endoatmospheric Defense. . . . .	114
Technical Overview of Endoatmospheric BAD. . . . .	114
LoADS With MPS Basing. . . . .	118
Other Endo Concepts . . . . .	126
Exoatmospheric and Layered Defense. . . . .	129
Technical Overview of Exo BMD .. . . .	129
The Overlay and Layered Defense of Silo-Based MX. . . . .	131
History of BMD and the ABM Treaty .. . . .	139
The ABM Limitation Treaty . . . . .	140
Application of ABM Treaty Provisions to MX Defense. . . . .	141
Future ABM Limitation Negotiations . . . . .	142

## LIST OF TABLES

<i>Table No.</i>	Page
20. Army's LoADSCost Estimate, October 1980 . . . . .	125

## LIST OF FIGURES

Figure No.	Page
59. Comparison of Ballistic Missile Defense Systems. . . . .	112
60. LoADS Defense Unit Before Breakout. . . . .	119
61. LoADSDefense Unit After Breakout. . . . .	120
62. Overlay/Underlay Layered Defense System . . . . .	131
63. Sensitivity of Layered Defense Performance to Overlay Leakage. . . . .	134
64. U.S. Defensive Arsenal Needed to Assure 1,000 Surviving U.S. Reentry Vehicles ., . . . .	135

Ballistic missile defense (BMD) systems — also called antiballistic missile (ABM) systems — would seek to ensure MX survivability by destroying attacking reentry vehicles (RVS) either in space or after they entered the atmosphere. Different BMD concepts can have very different capabilities and weaknesses which suit them for different MX basing roles. Thus, it is important to keep clear the context for which the defense is intended, i.e., whether it is desired to defend a large number of multiple protective shelters (MPS) or a relatively small number of silos. This chapter discusses the technical aspects of the entire range of endoatmospheric and exoatmospheric defense systems but will concentrate on the two BMD concepts most often discussed in the context of a near-term decision regarding MX basing: the Low-Altitude Defense System (LoADS),

which is suited for the role of enhancing the survivability of MX in MPS; and the Overlay component of a Layered Defense, appropriate in theory for defense of MX based in conventional silos.

There have been many changes in the technical nature of BMD systems in the past decade regarding both systems concept and underlying technology. Systems contemplated today are quite different from those discussed in the ABM debate of a decade ago. From a technical point of view, therefore, the issues relevant to that debate have been replaced by an entirely new set of issues. Though there are many parallels, intuitions based on previous acquaintance with BMD will not always be relevant — again from a purely technical point of view — to the systems contemplated today.

## OVERVIEW

### Technical Possibilities for BMD

It is useful to distinguish BMD systems according to the altitude regime in which they track their targets and make their intercepts, since this largely determines the effectiveness possible with such a system. Endoatmospheric — or “endo” — defense systems perform tracking and intercept within the sensible atmosphere, from the Earth’s surface to about 300,000-ft altitude. For various technical reasons, U. S. endo BMD efforts have concentrated lately on the low-altitude regime, below about 50,000 ft. Low-altitude endo systems such as LoADS are limited to making a small number of intercepts over a given defended target. If the number of targets is relatively small, as in the case of silo basing, such defensive systems can only exact a small number of RVS from the attacker. Low-altitude systems by themselves are therefore of limited value unless the number of targets or aim points is large, as with MPS basing. The very fact that their goal — forcing the offense to target a

small number of RVS at each aim point instead of one — is modest, means that low-altitude systems do not have to perform very well to achieve this goal.

Exoatmospheric — or “exo” — defenses track and intercept RVS in space. In contrast to low-altitude endo defenses, exo systems can in principle intercept many RVS attacking the same target. Systems with an exo component can therefore in theory defend a small number of targets such as silo-based missiles from a large attack. However, this more demanding task means that an exo system must be very good indeed to accomplish it. Thus, an exo system — even when accompanied by an endo system in a “Layered Defense” — must have a higher performance to do its job than a low-altitude system requires to do its more modest job.

In addition to specifying the capabilities of a BMD system, the altitude regime determines the type of sensor and interceptor required,

which in turn establishes the type of technology required for the system and its potential vulnerabilities (see fig. 59).

Endo systems normally employ ground-based radars and nuclear warheads to track and destroy targets. Radar blackout caused by nuclear detonations in the atmosphere is not a crippling problem for low-altitude endo systems, as it is for high-altitude endo systems, but it (along with other factors) imposes the limitation discussed above that only a very small number of intercepts can be made within a small area. Operation in the dense air at low altitudes means that it is very difficult for an opponent to fool the defense with decoys.

Operation in space would allow exo defense to make use of nonnuclear kill mechanisms and the tactic of preferential defense. Multiple kill vehicles can also be mounted on a single interceptor missile, resulting in some savings given the cost of boosting defensive vehicles into space in the first place. Infrared sensors are preferable to radars for exo defense. Without the filtering effect of dense air within the atmosphere, exo sensors are vulnerable to offensive tactics making use of decoys and other penetration aids.

### LoADS With MPS Basing

This use of BMD would be an alternative to increasing the number of shelters in an MPS

system in the face of a growing Soviet threat. In the Air Force baseline horizontal MPS system, for example, a LoADS defense unit would be hidden in one of the 23 shelters in each cluster and programmed to intercept the first RV approaching the shelter containing the MX missile. Since the Soviets would be presumed not to know which shelter contained the MX, they would have to assume for targeting purposes that each of the 23 shelters contained an MX missile defended by LoADS. If the defense were only able to intercept one RV over each defended shelter, the Soviets would have to target two RVS at each shelter instead of one. Thus, LoADS would increase the attack price for an MX missile from 23 to 46 Soviet RVS.

It is possible to have high confidence that LoADS could exact this price of 2 RVS per shelter if the locations of the LoADS defense unit; and the MX missiles could be concealed and if the defense unit could be hardened to survive the effects of nearby nuclear detonations. This confidence, conditional on successful deception and nuclear hardness, results both from advances in BMD technology in the last decade and from LoADS' relatively modest goal of exacting from the Soviets one more RV per aim point.

Preservation of location uncertainty (PLU) would be made more difficult with the addition of LoADS to the MPS system, since the LoADS defense unit, MX missile, and simu-

**Figure 59.—Comparison of Ballistic Missile Defense Systems**

	"Exo" atmospheric defense		"Endo" atmospheric defense	
	Overlay	Safeguard/Spartan	LoADS	Safeguard Sprint
operating area	space	Space	Lower atmosphere	Upper atmosphere
Type of sensor	Infrared	Radar	Radar	Radar
Location of sensor	On interceptor	On ground	On ground	On ground
KIH mechanism	Non-Nuclear	Nuclear	Nuclear	

SOURCE Office of Technology Assessment

lators must all have indistinguishable signatures. The nuclear effects requirements for LoADS are unprecedented. The design goals of PLU and hardening must furthermore be met simultaneously. It is not possible to have confidence that these goals can be met until detailed design and testing are done,

In addition to PLU and hardness, there are stylized attacks or "reactive threats" which could pose a long-term threat to LoADS. These risks are judged moderate,

#### The Overlay and Layered Defense of Silo-Based MX

The Army's concept of Exo defense, called the Overlay, would consist of interceptors, about the size of offensive missiles, launched into space from silos. Each interceptor would carry several kill vehicles that would be dispatched, using infrared sensing, to destroy attacking RVs before they entered the atmosphere. The Overlay could be deployed with an endo "Underlay" to make a Layered Defense of silo-based MX.

High efficiency would be required of the Overlay if it was to be able to defend a small number of MX silos against a large Soviet attack. The Overlay is in the technology exploration stage, and there is no detailed system design such as exists for LoADS. There are many uncertainties about whether the Overlay could achieve the high level of performance it would require to satisfy the needs of MX basing. These uncertainties concern both the underlying technology and the defense system as a whole. In addition, there is a potential "Achilles' heel" in the vulnerability of the Overlay to decoys and other penetration aids.

For the moment it would be quite risky to rely on the Overlay or Layered Defense as the basis for MX survivability.

#### Other BMD Concepts

This chapter will also discuss briefly other BMD concepts which have been studied,

A concept called "Dust," "Environmental," or "Ejecta" defense involves burying "clean" nuclear weapons in the vicinity of missile silos. The bombs would be exploded on warning of a Soviet attack, filling the air with dust which would destroy Soviet RVs before they reached the ground. Though there is little technical doubt about the high effectiveness of dust defense, there is considerable concern about public reaction to plans for the deliberate detonation of nuclear weapons on U.S. territory.

Various low-altitude or "last-ditch" concepts based on simple or "novel" principles have been proposed. Though perhaps relevant for other BMD roles, these concepts do not appear to have an application in MX defense, given the requirement to preserve a small number of MX missiles against a large number of Soviet RVs.

The Army's Site Defense is a derivative of the Sprint component of the Safeguard defense system of a decade ago. Based on the technology of the 1970's, Site Defense is preserved as an option in the event of a decision to field a BMD system based on known technology in a short period of time. Though inadequate for the role of MX defense, Site Defense could be appropriate for other limited BMD roles.

#### The ABM Treaty

The 1972 ABM Limitation Treaty was negotiated as part of the SALT I package of strategic arms limitation agreements. A Protocol specifying further I limitations was signed in 1974. The Treaty is of unlimited duration but is subject to review every 5 years. In addition, the Standing Consultative Commission created by the Treaty meets about every 6 months to review implementation of the provisions of the Treaty and to consider such matters as 'the parties might wish to raise.

Briefly, the Treaty and Protocol allow development of some types of ABM systems but limit their deployment to small numbers at

specified sites. Development of other types of ABM beyond the laboratory is forbidden altogether.

No meaningful defense of MX missiles, either in silos or MPS, would be permitted within the Treaty, since any such deployment could consist of at most 20 radars (18 small, 2 large) and 100 interceptors confined to the vicinity of Grand Forks, N. Dak., or Washington, DC.

Limitations on development constrain the types of ABM work that can pass beyond the laboratory stage. Since LoADS consists of radars and interceptors of the kind permitted by the Treaty, development of this system can

proceed without abrogation or renegotiation of the Treaty except where such development concerns the specific features of mobility, more than one interceptor per launcher, or a hypothetical reload capability. Development of the Overlay interceptors can proceed to the extent of testing single kill vehicles on interceptors, but development of multiple kill vehicles outside of the laboratory is forbidden. Development of space-, sea-, or air-borne ABM system components outside of the laboratory is also forbidden. The Treaty specifies that development of ABM systems based on "new technologies" unforeseen or unspecified at the time the treaty was drafted cannot be deployed.

## ENDOATMOSPHERIC DEFENSE

### Technical Overview of Endoatmospheric BMD

Endoatmospheric —or "endo" — defense systems perform tracking and intercept within the sensible atmosphere, from the Earth's surface to about 300,000-ft altitude. It is important to distinguish high-altitude systems, which acquire and track their targets above about 100,000 ft, from low-altitude systems, which track and engage below 50,000 ft. The Sprint component of the Safeguard system is an example of the former type and the Army's present LoADS concept is an example of the latter.

Endoatmospheric defense normally employs ground-based radars for tracking. Optical or infrared sensors would be inappropriate for endo operation because, among other reasons, they cannot supply accurate range information and low cloud cover or dust could obscure their view of incoming RVS.

Nonnuclear kill is possible in the atmosphere, but nuclear warheads provide a more certain kill mechanism. A nonnuclear kill would require that the radar provide very accurate trajectory information to the interceptor or that the interceptor have its own sensor. Because the kill radius of a nuclear warhead is

much greater, less accurate information suffices to guarantee RV destruction.

Neutrons released from a defensive nuclear warhead provide the mechanism for disabling the offensive RV. An RV warhead contains fissionable material that absorbs neutrons very readily: this is the property that allows the nuclear chain reaction to proceed when the RV is detonated. When the fissionable material in an incoming RV absorbed the neutrons from the defensive warhead, it would be rendered unable to detonate. Physical destruction of the RV would therefore not be necessary: though blast from the defensive warhead could play a role, it is a less certain kill mechanism. The neutron kill is sure because the incoming RV must contain neutron-absorbing material to do its job, and it is very difficult to shield against neutrons. A relatively low-yield defensive warhead (tens of kilotons) could generate a neutron fluence lethal to RVS at ranges of several hundred feet from its detonation point. The defensive interceptor therefore would not have to be very accurate to ensure disabling of the RV.

Use of nuclear interceptors does involve special procedures for their release, however. Release of offensive nuclear weapons must be

authorized by the National Command Authorities. The procedures for defensive nuclear release have not been worked out since the United States has no deployed, working BMD system.

#### Vulnerabilities of High-Altitude Endo Defense

The radar for the endoatmospheric Sprint component of Safeguard tracked incoming RVS above 100,000-ft altitude. Because of a number of technical problems associated with such high-altitude operation, U.S. BMD efforts in recent times have tended to focus on the low-altitude regime below 50,000 ft.

Target tracking and discrimination at high altitudes requires radars which are large and expensive. These radars, which must for cost reasons be few in number, would make tempting targets for a concentrated precursor attack designed to overwhelm the defense in the area of the radars and penetrate to destroy them. The defense system would then be blind.

In addition to the vulnerability of the radars, high-altitude endo defense suffers from two crucial technical problems: target discrimination and radar blackout. Discrimination refers to the ability to distinguish RVS from the bus and tank fragments which accompany them and from light decoys or other penetration aids which an attacker could design to confuse the defense. The defense would waste costly interceptors if the radar mistook a decoy or other object for an RV, and an RV would leak through if it were mistaken for a nonlethal object. High-altitude systems like the Sprint component of Safeguard would have high wastage and leakage because of the intrinsic difficulty of radar discrimination in the upper atmosphere. In the thin air at high altitudes, objects reentering the atmosphere without heat shields, such as bus fragments, have not yet started to burn up, and light decoys fall at the same rate as heavier RVS. The dense air in the lower atmosphere, on the other hand, acts like a filter: unshielded objects burn up, and light shielded objects slow down. In either case the heavy shielded RV can

be distinguished after it has reached low altitudes.

Blackout occurs when the heat and radiation from a nuclear explosion ionize the surrounding volume of air. This ionization causes attenuation and reflection of radar signals passing through the affected region. At the high altitudes where the Safeguard radars tracked their targets, blackout over large areas of the sky could be created by a rather small number of detonations. An attacker was therefore encouraged to launch a first salvo of warheads fuzed to detonate at high altitudes, thereby blacking out the defense's radars. The nuclear warheads on the defense's own interceptors could also produce this effect. The attacker could then bring in his main attack behind the protective blackout "shield."

#### Advantages and Limitations of Low-Altitude Endo Defense

Because of the vulnerability and cost of the radars and the severe technical problems of discrimination and blackout for high-altitude endo systems, U.S. efforts in endo defense have tended to focus on low-altitude systems, which track targets and perform intercepts below 50,000 ft.

Low-altitude systems are relatively impervious to decoy attack because it is possible to assess the weight of a body falling through dense air from its radar return. Weight is a strategically significant discriminant, since offensive boosters have limited throwweight. Beyond a certain point, loading decoys onto a missile requires offloading RVS, a trade that becomes unfavorable for the offense if the decoys must be heavy in order to fool the defense. The trade is clearly absurd (leaving aside the fact that a decoy might be cheaper than an RV) if the decoy must be as heavy as the RV itself, for the RV at least stands a chance of penetrating the defense and exploding whereas the decoy does not.

The procedure by which a low-altitude radar obtains a falling object's weight is difficult for even the cleverest decoy designer to sidestep

because it is based on fundamental principles which is not within the power of the offense to alter: the presence of dense air at low altitudes and some basic laws of physics. The rate of fall of an object — RV, decoy, bus fragment, etc. — through the atmosphere is determined by the ratio of its weight to its area, called its ballistic coefficient. The higher the ballistic coefficient, the faster the object falls. Of two objects of equal area, the heavier will fall faster because it has more force of gravity to overcome the resistance, or drag, of the air. Of two objects of equal weight, the smaller or more streamlined will fall faster because it does not have to push as much air out of its way. Thus, a flat sheet of paper falls slowly whereas the same sheet, when balled up, drops rapidly.

By tracking an object, a radar can measure its rate of slowdown and therefore the ratio of its weight to its area. In the thin air at high altitudes, however, differences in ballistic coefficient do not lead to large differences in rate of fall because there is not much drag. At low altitudes the differences are quite pronounced. Thus, discrimination on the basis of ballistic coefficient is more reliable at low altitudes.

Measuring the ballistic coefficient might not be sufficient for discrimination, however, since a small light decoy could have the same ballistic coefficient as a large heavy RV. It would in fact be quite difficult to design decoys which matched the ballistic coefficient of an RV at low altitudes since the shape of the RV (and hence its ballistic coefficient) changes in a complex way as its heat shield ablates. But as a hedge against a very carefully designed decoy, the defensive radar can employ another technique, involving the disturbance made in the air as the body passes through it, to obtain the area of the falling body. Combining the area with the ballistic coefficient gives the body's weight, a quantity that is not in the interest of the offense to match. Thus a low-altitude defense system which made use of these radar discrimination techniques would be virtually impossible to sidestep with decoys, since the fundamental discriminant is

weight and the techniques rely on **the basic** properties of gravity and hydrodynamics.

Radar blackout is not a crippling problem for low-altitude systems as it is for high-altitude systems.

However, fireball effects impose a basic limitation on the effectiveness of low-altitude defenses. The ability of low-altitude or "deep endo" systems such as LoADS to make multiple intercepts within a short time over the same site — a conventional missile silo or a shelter in an MPS system — is severely constrained, no matter how many interceptors the defense deploys. This limitation arises both from blackout in the regions of nuclear fireballs and from trajectory perturbations suffered by follow-on RVS passing through these regions. The technical nature of this problem, and the extent of the limitations it imposes, are discussed further in the Classified Annex. Even if a hypothetical future technology allowed the defense to overcome this fundamental limitation, there might still be strategies available to the attacker that were more efficient than saturation, such as precursor attack on the defense itself or use of various penetration techniques.

### How Good is Good Enough?

It is an important feature of low-altitude systems that only aim to make an attacker target one more RV at each aimpoint that they do not have to be very capable to force an attacker to pay this price. In fact, if the defense is only good enough that it succeeds in making its single intercept more often than it fails — how much more often is irrelevant—the attacker will conclude that he makes better use of his RVS by targeting two RVS at a lesser number of defended aimpoints than by targeting one RV each at a larger number. The attacker's conclusion is not a result of conservative offensive perceptions but of sober calculation.

To take an explicit, if oversimplified, example, suppose an attacker has 1,000 RVS to target at 1,000 aim points, each of which is defended by a defense system whose goal is a



single intercept per aimpoint. Suppose also that the defense performs so poorly that it succeeds in making an intercept only 51 percent of the time and fails 49 percent of the time. The attacker has the choice of targeting all 1,000 aimpoints with one RV (Case 1) or 500 aimpoints with two RVS (Case 2). In Case 1, the attack destroys 490 aim points because the defense fails this many times. In Case 2, all 500 aimpoints targeted 2-on-1 are destroyed by assumption. Thus the attacker concludes that he actually does better by “doubling up” on a smaller number of aimpoints (Case 2). But this is exactly what the defense seeks to force him to conclude.

Therefore, if the odds that a single-shot system actually makes its intercept are greater than 50 percent, it achieves its goal of forcing the attacker to target one more RV at each aimpoint. Whether the odds are 51 or 99 percent is immaterial, since the offense does not have the option of targeting fractions of RVS at each aimpoint, but only one or two.

Once the limited single-shot goal is accepted, a relatively poor system is as good as a perfect one. Although low-altitude endo interception is a very challenging task, defense systems do not have to perform it very well if they accept a goal of only one intercept per aimpoint. This stands in contrast to exo defenses, which aspire to a higher attack price than one RV per aimpoint. Such defenses are not worthwhile unless their performance is very good.

In the example above, the attacker was given the choice between 1-on-1 and 2-on-1 targeting of ballistic reentry vehicles. Stylized attacks or “reactive threats” involving non-ballistic RVS, precursor barrages, radar interference, etc. pose another set of challenges to single-shot defenses which must be analyzed on a case-by-case basis.

### The Need for Leverage

A generic low-altitude defensive system that could only claim a single RV per defended site would not be effective unless some additional defensive leverage could be found. One U.S.

defense unit (radar plus interceptor) would be a poor cost trade for a single Soviet RV unless intercept of this single RV resulted in the survival of a defended target valuable to the United States. But this would only be the case if the number of targets were so large that the Soviets could not afford to target multiple RVS at each one. If the number of targets were small, the Soviets could attack each with multiple RVS, overwhelm the defense, and destroy the U.S. value at an extra price, relative to the undefended case, of a small number of RVS. For instance, 100 single-shot low-altitude defense units defending 100 silos containing MX missiles would only be able to claim 100 RVS from a Soviet arsenal of thousands.

Additional leverage for the low-altitude defense could be provided in three ways.

Deceptive basing, such as for LoADS in association with MPS, would allow a small number of defense units to force the Soviets to expend a large number of RVS because they would not know which shelters were defended and would have to assume that all 4,600 shelters contained MX missiles defended by LoADS. Therefore, 200 LoADS defense units capable of a single intercept each would be able to exact a price of 4,600 RVS, forcing the Soviets to attack each shelter twice for a total of 9,200 RVS.

A so-called “cheap” or “simple” defense system such as Swarm jet, to be discussed later, could conceivably improve the cost tradeoff for single-shot defense, but the overall attack price would still be small if the number of defended targets was small, as with silo basing. If the simple system were *very* inexpensive, one could conceive of deploying one defense unit with *each* shelter in a MPS system. This would have the same effect as deceptive basing without the need for PLU. There does not as yet appear to be a simple interception system cheap enough to allow this possibility. However, dust defense could be cheap enough to deploy in this way.

Last, a capable “Overlay” defense operating outside of the atmosphere would also be a powerful source of leverage for an associated “Underlay” endo defense. The Overlay (if ef-

fective) would thin the attack and break up the structured laydowns of RVS needed to penetrate the Underlay. The Soviets would have to target many RVS at each defended site in order that a few leaked through in the right sequence to penetrate the Underlay. Such an attack strategy based upon leakage through the Overlay would be costly of RVS and exceedingly risky for the attacker.

Because of the need for extra leverage, proposals of low-altitude defense for MX missiles have focused on deceptive low-altitude defense for a many-aimpoint MPS basing system or on Overlay/Underlay (Layered) defense for a force of MX missiles deployed in a small number of conventional silos.

## LoADS With MPS Basing

### LoADS Description

#### THE DEFENSE UNIT (DU)

The LoADS defense unit (DU) would consist of a radar, data-processor, and interceptor missiles. The radar would be of the phased-array type, operating at high frequencies and with high power and narrow beamwidth for extra anti jam capability. The data processor would employ distributed processing for rapid throughput of large amounts of trajectory data. The interceptor missiles, roughly one quarter the length of an MX missile and half as wide, would be capable of extremely high accelerations and rapid change of direction. The inertially guided interceptor would be directed at launch towards a predicted impact point with the RV but its course could be updated in flight as well. The interceptor would be armed with a low-yield nuclear warhead. The technologies embodied in these elements of the DU represent significant advances beyond earlier U.S. endo BMD systems.

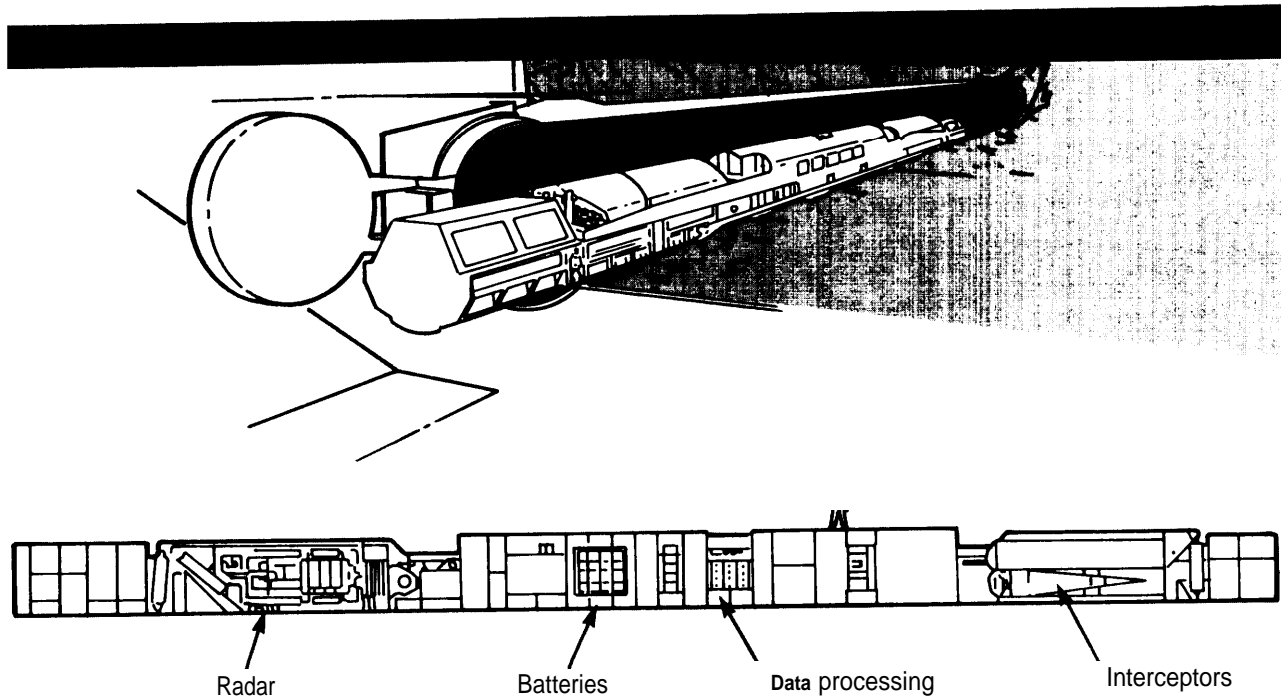
For the purpose of LoADS/MPS combination basing, the elements of the DU would be packaged into cylinders capable of fitting into the same spaces in the shelters and transporters occupied by the MX missiles and simulators (see fig. 60). The DU, MX cannister, and simulator would be so designed that they presented identical signatures to sensors which

the Soviets might use to distinguish them in the shelters or in transit. It would be essential to the effectiveness of the LoADS/MPS combination that it be impossible to distinguish MX, DU, and simulator.

One DU would be deceptively emplaced in each cluster of 23 shelters, along with the MX missile and 21 simulators. The DU would be programmed to defend the shelter containing the MX missile. Upon receiving warning of a Soviet attack, the DU would erect vertically, pushing the radar face and the interceptor cannister through the roof of the shelter (see fig. 61). The DU would then be ready to defend the shelter containing the MX. Breakout would be an irreversible process, since it would destroy the roof of the shelter. Various schemes have been studied to avoid breakout. For instance, the DU could roll out the door of the shelter and erect like the MX missile. But the DU in this exposed position would be too vulnerable to destructive effects of nearby nuclear detonations. The broken-out DU would still have the protective shielding and structural support of the remainder of the shelter.

It would be absolutely essential that the defense received adequate warning that Soviet RVS were approaching so that it could awake electronic equipment from its dormant state and break out. It appears that this process of readying the LoADS DU could be performed in a short period of time. If achievable, this would mean that it would not be necessary to have warning sensors which detected a Soviet attack at the moment of launch, but only as the attacking RVS approached the United States. This late warning would be easier to provide than the early warning required to support launch under attack or exo BMD. It would also be easier to protect warning sensors of this type from a Soviet precursor attack. It might also be desirable to have some information about the size of the attack before a decision were made to break out. (This is discussed further in the context of Shoot-Look-Shoot in the Classified Annex.) Finally, the command, control, and communications to support timely breakout would require procedures and hardware immune to a determined Soviet ef-

Figure 60.— LoADS Defense Unit Before Breakout (human figure indicates scale)



SOURCE Office of Technology Assessment

fort to disrupt them. Several technically feasible approaches to these problems have been proposed, and their provision would be essential to effective defense.

#### LoADS OPERATION

The LoADS DU in each cluster would be programmed to defend the shelter containing the MX missile. Since the Soviets would not know which shelter contained the MX if PLU were maintained, they would have to assume for targeting purposes that each of the 23 shelters contained an MX missile defended by LoADS. LoADS would intercept the first RV attacking the MX shelter, so the Soviets would have to target *each shelter twice* in order to destroy the MX. LoADS would double the price the Soviets would have to pay for an MX missile from 23 to 46 RVs. Thus U.S. deployment of LoADS would be essentially equivalent to doubling the number of shelters in the MPS deployment while keeping the number of missiles the same.

deployment while keeping the number of missiles the same.

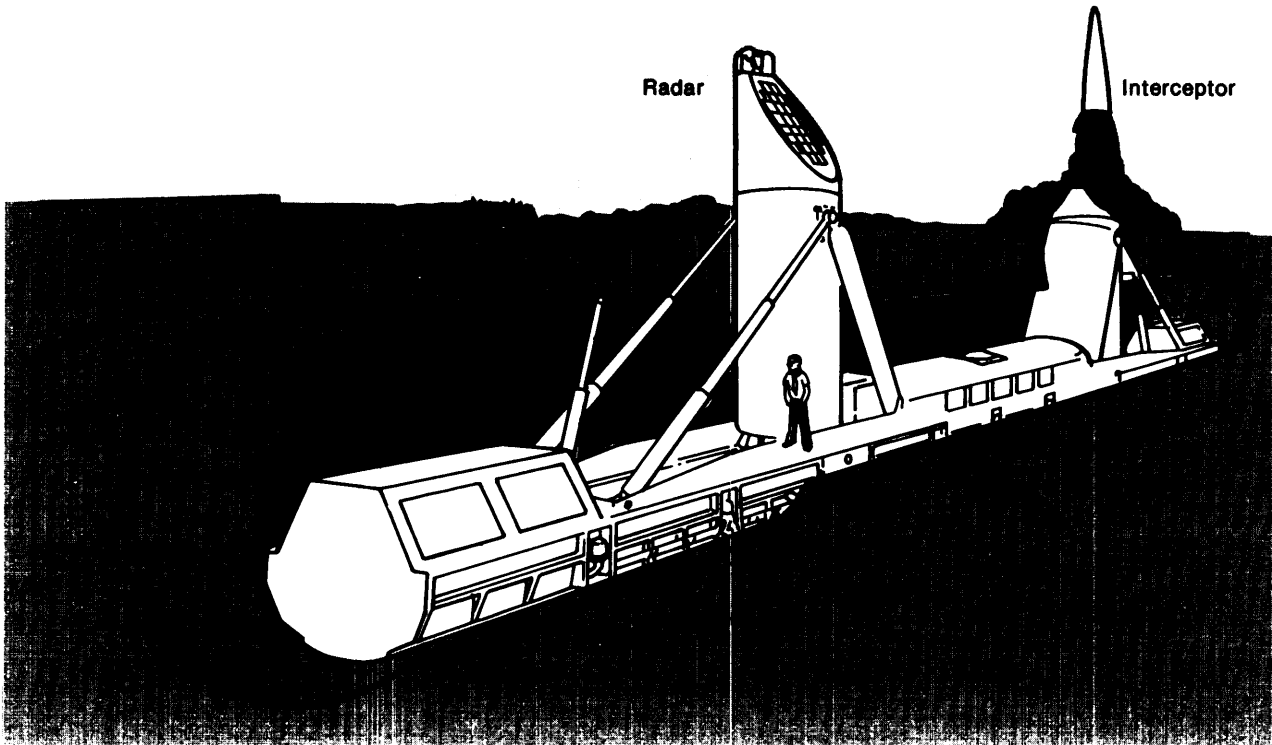
It is desirable for each DU to have more than one interceptor in order that it could defend itself if it came under attack before the MX shelter did.

It would be essential that the location of the MX be unknown to the Soviets. It would also be necessary to conceal the location of the DU, since if this were known the Soviets could attack the defense first, forcing it to use up its interceptors in self defense. Subsequent attack on the other shelters would find them undefended.

#### LoADS WITH VARIANTS OF MPS

The operation of LoADS would be essentially unchanged if the MPS deployment were organized into "valley clusters" containing several missiles instead of discrete clusters of

Figure 61 .— LoADS Defense Unit After Breakout (human figure indicates scale)



SOURCE Office of Technology Assessment

23 shelters for each missile. A DU could still be provided to defend each missile, and the attack price per missile would again be doubled.

From the point of view of LoADS defense, there would be significant tradeoffs between horizontal and vertical shelter deployment but no clear reason to prefer one to the other. For vertical shelters, it would be necessary to put the radar and missile cannister in different shelters, since they would be too large to fit side-by-side in a single shelter. There would have to be a data link to connect the two elements of the defense unit. Since the units would be moved from shelter to shelter periodically, the communications equipment would have to connect all pairs of shelters, potentially a costly addition. The links would furthermore have to be resistant to disruption from nuclear effects. On the other hand,

breakout would not be required, since the defense could egress through the blast door of the vertical shelter. Matching four objects (MX, simulator, radar module, and interceptor cannister) would be more difficult than three, but there would be more design flexibility for the separate radar module and interceptor cannister because each would be, so to speak, "half empty." The extra room could be used for PLU countermeasures. Protecting the DU elements from nuclear effects could conceivably be easier for vertical shelter deployment.

It is not possible at this time to assess these tradeoffs in detail, but it is not apparent that either vertical or horizontal offers clear advantages. More study has been made of the horizontal alternative.

## LoADS Effectiveness

Active defense systems are very complex: the interception process is complicated, with many distinct sources of leakage and wastage. There are many attack scenarios, offensive countermeasures, and defensive counter-countermeasures to consider. Analysis of the effectiveness of a BMD system can therefore be more involved than analysis of basing systems that ensure survival of MX by passive means such as mobility, concealment, or deception. It is therefore important in assessing how well LoADS would do its job to be very clear what that job is.

Suppose LoADS sought to double the price the Soviets would have to pay to destroy an MX missile from 23 RVs to 46 RVs. In this case, LoADS would have the rather modest task of intercepting the first RV targeted at the MX missile within each cluster. In order to destroy the MX missile within a cluster, the Soviets would have to target two RVS, or “double up,” at each shelter. This assumes that PLU would be successful and the Soviets would have no knowledge of the location of the MX or the DU.

In fact, LoADS could exact the price of 2 RVS per shelter even if the defense system were rather inefficient. Roughly speaking, if the Soviets believed that LoADS would successfully intercept the first RV targeted at the MX shelter more *than half of the time*—that is, if the efficiency of LoADS were greater than only 50 percent—then the Soviets would calculate that they made better use of their RVS by doubling up on fewer shelters than by targeting many shelters with one RV.

For example, suppose that the Soviets had 6,900 RVS to target at 4,600 MX shelters. (These numbers are chosen to make the arithmetic easy and for no other reason.) Suppose also that LoADS were only *51-percent* efficient in a 1-on-1 attack: that is, if one RV were directed against every shelter, LoADS would successfully intercept 51 percent of the RVS directed at the shelters containing MX. This is the same as a leakage of 49 percent. Assume also that all targeted Soviet RVS actually

arrived on target and further that if two RVS arrived at the MX shelter within a short space of time, LoADS would not even attempt to intercept the second and the MX missile would be destroyed.

The Soviets would have the choice of using their 6,900 RVS either to target 100 clusters (2,300 shelters) with one RV and 100 clusters (2,300 shelters) with two RVS (Case 1) or to double up on 150 clusters (3,450 shelters) and leave 50 clusters (1,150 shelters) untouched (Case 2). In Case 1, all 100 MX missiles targeted 2-on-1 would be destroyed, and 49 of the missiles targeted 1-on-1 would be destroyed because LoADS would only be 51-percent efficient by assumption. Thus in Case 1 the Soviets would destroy 149 MX missiles. In Case 2, the 150 missiles targeted 2-on-1 would be destroyed and the remaining 50 untouched. The Soviets would therefore actually destroy more MX missiles by doubling up (Case 2), even though LoADS failed to make an intercept almost as many times as it succeeded.

It therefore appears that LoADS would not have to be very efficient to exact a price of two RVS from the Soviets. At the same time, it would be exceedingly difficult to exact a price of several RVS.

So far, the analysis has considered only simple 1-on-1 or 2-on-1 attacks. The conclusion is that, as far as these attacks are concerned, and *assuming* the DU survives nuclear effects to do its job and that PLU is maintained, it is possible to have confidence that LoADS is capable of its job. Although low-altitude interception of RVS is a very challenging technical task, and there are many uncertainties about LoADS operation and potential contributors to inefficiency (radar and interceptor performance, RV radar cross sections, radar traffic handling, kill mechanisms, etc.), there are none which should stop LoADS from doing its job as well as it needs to.

If the defense only sought to make one intercept over the MX shelter, then the United States could assume that the Soviets would pay the price of 46 RVS per MX missile if given the choice of 1-on-1 or 2-on-1 targeting. Could

they do better by using special attack strategies?

There are many such reactive threats to LoADS. For instance, decoys are a hypothetical threat: precision decoys seek to fool the radar into intercepting them, while traffic decoys simply aim to fool the radar long enough to consume precious data-processing time. As discussed in the Technical Overview, the ability of radar to weigh falling objects at low altitudes means that decoys are probably not a serious threat to LoADS. Jammers deployed along with attacking RVS could seek to blind the radars. Maneuverable reentry vehicles (Ma RVs) could try to evade the interceptor; and if MaRVs were provided with radar-homing devices, they might destroy the LoADS defense units before they had done their job. These reactive threats are discussed in the Classified Annex. Defense barrage, blackout, and exhaustion attacks are discussed under *Hardness to Nuclear Effects* and its Classified Annex, and Spoof and Shoot-Look-Shoot, both threats to deception, are discussed under *Preservation of Location Uncertainty (PLU)* and its Classified Annex.

One can raise legitimate questions as to whether a prudent Soviet planner would use any of these techniques to sidestep LoADS, but the defensive planner must fortify the system design against all of them. The attractiveness of these special threats to Soviet planners would presumably be weighed against the benefits they would derive from the simple expedient of deploying two Soviet RVS for every U.S. shelter. Detailed analysis of these special threats, presented elsewhere in this report or its Classified Annexes, indicates that some of them are worrisome and represent a long-term risk to the effectiveness of LoADS/MPS.

### Hardness to Nuclear Effects

The close shelter spacing—1 mile—means that LoADS must operate in a nuclear environment of a severity unprecedented for so complex and exposed a piece of equipment. Failure to meet the requirements could lead to pronounced degradation in system performance. It is also vital that measures taken to pro-

tect the DU do not betray its location, i.e., break PLU. Providing for nuclear hardness requires detailed understanding of the expected nuclear environment and its effect on critical mechanical and electrical components. Especially important for LoADS, given the unprecedented character of the hardness requirements, is testing of actual equipment. DU design and nuclear effects analysis—and, in the case of LoADS, PLU analysis—must proceed in concert. These studies are just beginning. Testing is required before it will be possible to have confidence that LoADS can meet its hardening needs, especially within the severe design constraints imposed by PLU.

As with the analysis of system effectiveness, it is important to have a clear idea of LoADS' hardening needs and of the consequences of failing to meet these needs. The key requirements concern the survival of the DU, and especially the radar, after it has broken out of the shelter and is waiting to intercept the RV targeted at the MX shelter. Other concerns, probably less serious, are the hardness of the interceptor as it flies to make its intercept and the hardness of the DU before it breaks out.

### HARDNESS OF THE DU AFTER BREAKOUT

For LoADS to do a single-shot job, no less than 46 Soviet RVS may suffice to destroy an MX missile. The attacker must either be made to fail to destroy the DU before it has made its intercept or be made to pay a heavy enough price to destroy the DU that nothing is gained by trying.

The hardness of the broken-out DU defines a "keep-out zone" around the unit: RVS which detonate within the keep-out zone are assumed to destroy the DU and must be intercepted if they arrive before the DU has made its intercept above the MX shelter. It is for self-defense that each DU should contain more than one interceptor missile.

Inadequate nuclear hardening would mean that the keep-out zone was too large. An illustrative, if presumably exaggerated, example consists of a DU so soft that a detonation anywhere within its shelter cluster would im-

pair its function. In this case, the Soviets could target a few RVS (perhaps of higher yield than those targeted at shelters) to arrive at random locations within each cluster a few seconds before arrival of the main attack. The main attack would consist of one RV on each shelter. The DU would have no choice but to intercept all of the precursors, for otherwise it would be rendered inoperable. If there were as many precursor RVS as interceptors in the DU, then all the interceptors would be used up in self-defense. The main attack would then find the cluster undefended, as though LoADS did not exist. The attacker would then have paid not 46 RVS, but rather the undefended price of 23 RVS plus just a few additional RVS to exhaust the defense,

The defense suppression barrage described above is one of several scenarios where LoADS hardness plays a crucial role. In all of these scenarios, the attacker seeks to destroy an MX missile for an attack price of less than 46 RVS. The results of a more detailed analysis, presented in the Classified Annex, indicates that the 1-mile shelter spacing imposes severe requirements on the DU. Unlike the MX missile, protected by its steel and concrete shelter and several feet of earth, the DU is directly exposed to the nuclear effects. Not only must the DU survive, but its complex components must function through the attack. Thus, some effects— prompt radiation, certain effects of electromagnetic pulse (EM P), dust, etc. — which are not important for missile protection are severe threats to LoADS. Defense performance, measured by vulnerability to these stylized attacks, might be degraded appreciably by shortcomings in hardening.

Work on LoADS hardening so far has concentrated upon defining quantitatively the nuclear effects which the DU must be able to endure, not providing design fixes for potential vulnerabilities. Even defining the effects will require testing, since in some respects they exceed the predictive power of computer simulation codes. Understanding the interaction or “coupling” of these effects to the peculiar geometry of the broken-out DU, to electronics,

and to radar performance will also require testing.

Nothing that is done to ensure its hardness must permit the DU to be detected when it is in the shelter. If the Soviets were able to detect which shelter contained the DU, they could target that shelter with a few precursors, forcing it to exhaust itself in self-defense. This and other threats to PLU are discussed in the next section. The important point is that hardening the DU —adding shielding, structural support, etc. — must not provide a signature which would allow the Soviets to detect the DU'S location. This synergism of hardness and PLU is a matter of testing and detailed design which has not yet been done.

Ensuring adequate hardness for the broken-out DU is thus a challenging task, and it will require some time ‘before uncertainties can be reduced to levels where a final judgment is possible.

It is important finally to note the constraints that would act upon the offense if it were to seek to exploit potential vulnerabilities in LoADS. If the Soviets were to fractionate so as to be able to target as many shelters as possible, they would have to reduce the yields of their RVS. The lower yields would significantly alleviate the nuclear effects on LoADS in some, though not all, circumstances. If on the other hand, the Soviets kept their yields high with the aim of exploiting potential LoADS vulnerabilities, it would be difficult for them to fractionate their missiles,

#### HARDNESS OF THE IN-FLIGHT INTERCEPTOR

As the missile flew towards its intercept point, it would be buffeted by the shock waves from nearby detonations. Though the interceptor has the ability to correct its course, it has a limited duration of powered flight. If intercepting an RV at a relatively distant point, burnout would be complete before the interceptor reached the RV. When coasting in this way, it would have less ability to correct its course than when burning.

Interference with interceptor performance due to nuclear effects such as shock waves is

one of the many contributors to system leakage. As described in the previous section, LoADS can tolerate a large leakage without impairing its overall effectiveness. Thus in-flight nuclear effects might not **serve** to increase leakage above an acceptable point. However, interceptors flying out to attempt multiple intercepts would be forced to fly in a severely disturbed environment.

#### HARDNESS OF THE DU IN THE SHELTER

In the context of a Spoof or Shoot-Look-Shoot attack, to be discussed in the next section, the DU might be required to survive a light precursor attack before it broke out of its shelter. In this situation the DU would be relatively secure because it would be in the shelter and the scenario calls for a light attack.

Additional discussion of the problems with meeting LoADS' nuclear hardening requirements can be found in the Classified Annex.

#### Preservation of Location Uncertainty (PLU)

Successful deception is vital to LoADS' defensive leverage. If the location of the DU were known to the Soviets, they could exhaust the defense with a precursor attack. A subsequent one-on-one attack would find the shelters completely undefended. What is more, under certain circumstances, a breakdown of PLU for the LoADS DUS could cause a breakdown of PLU for the MX missiles as well. In this case, the United States would be worse off than if there were no defense at all.

For undefended NIPS, PLU appears to be a complex and challenging technical enterprise, but no signatures of the MX missile have been identified which present clearly insurmountable problems. PLU for the LoADS/MPS combination has not yet progressed this far, and the problem will have to be reduced to a comparable "acceptable" level of detail. In particular, the design requirements imposed by nuclear hardening must be taken into account.

Even if no "Achilles' heel," or gross signature of the DU which is fundamentally incompatible with PLU, is found, a complex engineering task faces the LoADS designer. In

the case of MPS alone, one is presented with 200 missiles and the task of creating 4,600 simulators which resemble the missiles in all observable respects. The simulator is created de novo, with no a priori constraints save to match the MX. The LoADS Defense Unit, on the other hand, is a functional object with unique signatures, related to its operation, which cannot be suppressed. It would therefore be virtually impossible to make the DU match a set of missiles and simulators which were not designed with the LoADS option in mind. The three objects — MX, simulator, and DU — must all be designed in concert.

PLU is therefore considerably more complex for MPS defended by LoADS. It is too early to tell whether deception can be arranged at all, but it is probable that the 200 missile canisters and 4,400 simulators would have to be altered from time to time as design and testing proceeded to accommodate distinctive features of the DU. The later that a decision were taken to give LoADS a place in the design of the overall system, the riskier and more costly the PLU process might become.

In addition to signatures, the operations by which the MXS and DUS were shuffled periodically among the shelters must not betray the location of either. It appears that acceptable "movement algorithms" can be devised to preserve PLU for both MX and DU simultaneously, whether the system were organized into individual clusters of 23 shelters or into larger "valley clusters." It should be noted that if rapid reshuffle were required to redress actual or suspected loss of PLU, extra time might be required, depending on the availability of transporters, to move the DU as well as the MX missile.

There is some concern regarding a tactic for attacking LoADS/MPS, called Shoot-Look-Shoot, whereby the Soviets could in principle induce a breakdown of PLU. If the Soviets launched a first wave of attacking RVS which caused the LoADS DUS to break out and expose their locations to remote Soviet sensors, a second wave could be targeted on the basis of known DU locations. They would then be able



to destroy MX missiles at about the undefended price or even less. However, to sidestep the defense in this way, the two waves of attacking RVS would have to be well-separated in time. The Soviets would therefore have to reckon with the possibility that the United States would simply launch MX missiles at the Soviet Union between waves rather than await the outcome of a subtle Soviet strategy. For this and other reasons, reliance on Shoot-Look-Shoot would entail high risk to the Soviets. The Soviets would presumably weigh these risks against the simpler expedient of building more RVS and attacking the shelters directly.

There are two scenarios for which a Soviet Shoot-Look-Shoot capability could be intended. In the first (sometimes called "Spoof") scenario, an initial attack on LoADS/MPS is intended to cause the DUS to break out of their shelters. A second wave of RVS is then targeted on the basis of known DU locations. In the second case, appropriate to long war scenarios, a second attack is not necessarily planned at the time of the first, but after an initial exchange in which the DUS had broken out to perform their defensive job, the Soviets could sense the locations of the exposed DUS. In a subsequent exchange, the remaining U.S. force would be left essentially undefended. Shoot-Look-Shoot would in this case mean that the LoADS defense did not have the endurance that the MX missiles themselves would have.

Since deception is necessary for defense effectiveness, since the defense unit must break out and expose itself to defend, and since the Soviets would know that a shelter defended in the initial attack must have contained an MX missile, a Shoot-Look-Shoot strategy would enable the Soviets to compensate for LoADS with only a few hundred more RVS than they would need to attack an undefended MPS, *provided* the United States did not launch out between the first and second waves. Calculations of the outcomes of various Shoot-Look-Shoot scenarios, and a discussion of the problems faced by the offense in mounting them and the defense in countering them, are provided in the Classified Annex.

## Cost and Schedule

OTA has not performed independent cost and schedule analysis for the LoADS/MPS combination. The data presented in this section were supplied to OTA by the Army's Ballistic Missile Defense Systems Command (BMDSCOM). Comments that accompany these data are those of OTA and do not necessarily reflect opinions of BMDSCOM.

The Army's most recent (October 1980) cost estimate to deploy a LoADS defense for the 4,600-shelter Air Force baseline MPS system and operate it for 10 years is 8.6 billion constant fiscal year 1980 dollars. The \$7.1 billion acquisition cost would include the costs of the DUS, 200 separate transporters to move the DUS, a modest amount of construction of operating buildings in the deployment area, and program development and management. Operating costs are estimated at \$153 million per year. A detailed breakdown is presented in table 20. These cost estimates do not include the costs of potential modifications to the Air Force baseline system in order to accommodate LoADS nor the cost of additional tactical warning and threat assessment systems and command, control, and communications (C) systems to support LoADS.

The present LoADS Program schedule is funding- and Treaty-constrained, and precise schedule information is classified. A schedule

**Table 20.—Army's LoADS Cost Estimate,  
October 1980'  
(constant fiscal year 1980 dollars in billions)**

Research, development, testing, and engineering . . . . .	1.75
Defense units . . . . .	3.20
Transporters . . . . .	1.13
Military construction . . . . .	0.16
System engineering and program management . . . . .	0.54
Other investment . . . . .	0.32
Acquisition cost . . . . .	7.10
Operations cost (10 years @ 0.15) . . . . .	1.53
Total . . . . .	8.63

<sup>\*</sup>From figures supplied by Army BMDSCOM

SOURCE Office of Technology Assessment

that assumes that the decision to remove constraints were not made until late in the decade provides for final operating capability (FOC) for the LoADS addition to MPS several years after MPS FOC. This schedule would not require amendment of the ABM Treaty reached at SALT I until later in the decade.

An accelerated schedule, assuming an early decision and release from constraints, could provide for LoADS deployment on about the same schedule as MPS deployment. This would require early amendment or abrogation of the ABM Treaty and funding well above that now projected for the LoADS Program.

### Other Endo Concepts

Other endo BMD concepts besides LoADS have been proposed and investigated. Dust defense is technically feasible and very capable but could have very low public appeal as well as a few potential technical drawbacks. Terminal or low-altitude defenses based on "simple" or "novel" concepts could be adequate as single-shot last-ditch defenses of hardened targets against a small attack but have not been proposed with the demanding MX role in mind. The Army's Site Defense represents the technology of the 1970's and is inadequate for the MX role.

### Dust Defense

Dust defense—also called environmental defense — provides for burying "clean" nuclear weapons in silo or MPS fields and exploding them shortly before attacking RVS arrive. The dust and debris lofted into the air would destroy approaching RVS either by direct collision with large earth fragments or by dust erosion of the RV'S heat shield. The detonations would be placed so as not to damage the ICBMS in their silos or shelters.

There are two possible ways of employing dust defense. In the first, nuclear weapons would be buried north of each silo or shelter and exploded seconds before RV arrival. Small radars placed north of each site would provide the detonation signal. The RV would be destroyed in passage through the dense plume of

debris thrown up immediately by the explosion. The dust cloud which forms a little later at higher altitudes would provide additional protection for a longer period of time than the debris stem, which falls back to Earth in a short time.

In the second scheme, a smaller number of weapons of higher yield would be exploded throughout the fields several *minutes* before Rv arrival. The heavy debris would thus have fallen by the time the RV arrived, but by that time the dust cloud would have formed. Since the dust cloud from a high-yield weapon can be tens of miles in width and breadth, many silos could be protected by a single dust cloud. Protection would last for approximately 20 minutes after which another set of weapons would have to be detonated to provide continuing protection.

The weapons detonated would destroy far more megatonnage than they constituted themselves, a fact which makes the deliberate detonation of nuclear weapons on U.S. territory somewhat more palatable from the standpoint of fallout. But a more important factor in reducing fallout is the possibility, much discussed in the 1960's at the time of the PLOWSHARE Program studies of the peaceful use of nuclear explosions, of constructing nuclear weapons which produce very little residual radioactivity.

Conventional nuclear weapons give rise to radioactive fallout in two ways. First, a certain fraction of the weapon yield is produced by fission. The fission products are unstable isotopes which give off harmful radiation when they decay into more stable species. The rest of the weapon yield is provided by fusion. Large numbers of neutrons are formed in the fusion process, and when these neutrons encounter ordinary material in the vicinity of the detonation, they transform it into radioactive material.

Clean weapons reduce both sources of fallout. First, the clean weapon is constructed in such a way that very little of the yield is due to fission. Second, one can surround the **weapon** with material, such as berated water, which ab-

sorbs the fusion neutrons readily without becoming radioactive. Such a clean bomb is not as compact as an ordinary nuclear weapon. It might occupy the volume of a room. For that reason, underground vaults would be dug in the silo fields to house the clean weapons. In this way the radioactivity from the clean explosions could be reduced to about one *one-hundredth* of the radioactivity from conventional nuclear weapons of equal yield.

Though there is some uncertainty in the composition of the stems and dust clouds formed in nuclear explosions (which cannot be entirely resolved within the Test Ban Treaty), there is general agreement that dust defense is an effective way to destroy attacking RVS. There appear to be no effective measures that the Soviets could take to protect their RVS. Moreover, large numbers of RVS could be destroyed within a short space of time in this way, a feat that is impossible for more conventional endo defenses.

Potential drawbacks to dust defense, besides its perceived unpalatability, are the need for warning, the need to provide multiple explosions if the attack occurs in waves well-spaced in time, and the fear of error.

The cloud variety of dust defense requires warning because the weapons must be detonated several minutes before attacking RVS arrive. In principle, the stem variety does not require warning beyond that provided by its radar, but it might be considered inadvisable to keep the system activated at all times, since a radar malfunction in peacetime might cause inadvertent detonation. Since warning is not needed until late in the flight of the attacking RVS in either case, it is easier from the technical point of view to provide an adequate system of this type than one which provides warning at the time of missile launch. This type of warning is needed by all endo defense systems.

An attack that came in waves could require multiple detonations. If backup weapons were buried to provide the capability for multiple detonations, the weapons would have to be spaced far enough apart that the first detonation did not destroy the remainder. One U.S.

response to a multiple-wave attack would simply be to launch in retaliation rather than await the next wave. Offensive missiles can be made that can launch through dust clouds without damage. Dust defense could therefore extend the timeline for launch under attack by forcing the Soviets to attack in two waves. The first wave would be destroyed by the dust, and the second wave could not be launched until the dust cloud had dispersed. The United States would have this extra time to decide on a response.

Error in the form of inadvertent or unauthorized detonation of the buried weapons could be avoided by the same set of procedures which prohibit launch of offensive missiles. The real possibility of error lies in a false warning message causing authorized detonation. Fear of this type of error and procedures to avoid it could lead to another type of error: failure to authorize detonation when the warning information was correct. The problems here are similar to those of a launch under attack system.

Dust defense could therefore be by far the most potent endo defense system. However, it is seldom taken seriously because of concern for public reaction.

### Simple/Novel Systems

Simple/novel systems is a catch-all for a wide variety of low-altitude or last-ditch defenses of hardened targets. Examples go by such names as Swarm jet, Porcupine, Gatling Guns, SID CEP, Quickshot, SSICM, Bed of Nails, and Agile. The interceptors consist of rockets, shells, or inert projectiles with or without nuclear warheads and guided by land-based radars or homing sensors. Not all are simple, though many are novel indeed. LoADS itself could be classed with these systems, since it has a similar goal.

Because low-altitude defenses cannot guarantee multiple intercepts over a single target in rapid succession, they are inadequate to defend a small number of targets against a large Soviet threat. Indeed, most simple/novel systems were conceived as cheap and quickly de-

ployable ways to increase the Minuteman attack price and create uncertainty for Soviet targeters.

Some simple/novel systems might therefore have capabilities similar to LoADS, though none has been studied in the depth that LoADS has. A simple/novel system might therefore in principle be capable of replacing LoADS in the MPS basing role. This could come about either by providing a last-ditch system simple and cheap enough to deploy in association with each of the 4,600 MPS shelters, or compact enough to fit into a shelter deceptively like the LoADS Defense Unit. However, none of the concepts yet proposed combine confidence in technical feasibility with low cost or small size such that they would be attractive replacements for LoADS in the MPS role.

Because of the interest in simple/novel systems, two of the most promising examples are discussed briefly below,

#### SWARM JET

The Swarm jet concept consists of radars deployed north of each defended site and a launcher located near the site and containing thousands of spin-stabilized, rocket-propelled projectiles. When the radar detects an attacking RV, the launcher pivots in the direction of the predicted intercept point and the projectiles launch into the threat tube in a swarm. Each projectile weighs a few pounds and is designed to destroy an RV completely in a hypervelocity collision seconds before arrival at the silo. Swarm jet is designed to be constructed from already-available or easily manufactured components.

The object of the defense is to fill the sky in the path of the attacking RV with enough projectiles to assure high probability of collision. Though there is agreement among those who have studied Swarm jet that collision with a projectile will indeed destroy an RV, there is disagreement about how many projectiles are needed to assure a high collision probability. This disagreement translates into uncertainty in the size and cost of an effective Swarm jet deployment. Factors that enter into the uncer-

tainties are radar performance, the pointing and aerodynamic properties of the projectiles, and the effects of blast waves from precursor or nearby nuclear detonations.

Like other low-altitude defenses, Swarm jet is essentially a single-shot system and could therefore claim with confidence only one RV per silo from an attacker. The Swarm jet launcher might be too large to fit into an MPS shelter; if this were the case, the only way to deploy it with MPS basing would be to provide one Swarm jet unit for each shelter. This would be costly but might deserve consideration if deception proves too difficult for LoADS/MPS.

#### AGILE INTERCEPTOR

The idea of an Agile interceptor is to get beyond the single-shot limitation of low-altitude systems by providing an interceptor so maneuverable that it can intercept follow-on RVs after detonation of a first despite poor radar impact-point prediction due to fireball and despite being thrown off-course by blast waves and winds. This program is in the research stage.

The goal of the Agile interceptor is to intercept a few, but not many, RVs over a single silo. Because its goal remains modest and because the technology is yet unproved, this concept is considered unsuitable for MX defense.

#### Site Defense

The Army's Site Defense is a derivative of the Sprint component of the Safeguard defense system of a decade ago. As a high-altitude endo system, it is susceptible to blackout, penetration aids, and direct attack on its few, large radars, as described in the *7-ech;ca/ Overview*. Based on the technology of the 1970's, Site Defense is preserved as an option in the event of a decision to field a BMD system based on known technology in a short period of time.

Though inadequate for the role of MX defense, Site Defense could be appropriate for other BMD roles. For instance, it could be used as a "threshold defense" for some important U.S. assets such as warning sensors. In the con-

cept of threshold defense, no pretense is made that the defense can ensure survival of the defended asset; its role is rather to increase the attack price to the point where a Soviet at-

tempt to destroy the defended targets would require such a large attack as to constitute a major provocation deserving of major U.S. response.

## EXOATMOSPHERIC AND LAYERED DEFENSE

### Technical Overview of Exo BMD

Exoatmospheric — “exe” — defense holds high promise in theory because the long flight times of RVS outside the atmosphere and the large battlespace mean that many RVS targeted at the same site can be destroyed. In contrast to low-altitude systems, systems with an exo component could in theory defend a small number of targets such as MX silos against a large number of Soviet RVS. Additional strengths of exo BMD are the feasibility of nonnuclear kill, the possibility of mounting multiple interceptors on a single booster rocket, and the concept of adaptive preferential defense

### Theoretical Advantages to Exo Operation

Nonnuclear kill is possible in space for several reasons. First, the defensive sensors would have a relatively long time—minutes, as opposed to seconds for an endo defense—to track their targets, and the trajectories of attacking RVS would be predictable because they would be passing through empty space. It would therefore be possible for the interceptor to aim close enough to the RV that the large destructive radius of a nuclear warhead would not be necessary. Deployment of barriers of material in the paths of approaching RVS would also be easier in the vacuum of space. Nonnuclear kill is preferable to nuclear methods because a nuclear defense’s own warheads could interfere with its sensors (assuming the offense did not employ its own nuclear precursors), nuclear warheads are relatively expensive and heavy, and activation of a nuclear defense would require procedures for authorized nuclear release.

Interceptors boosted into space for exo defense could also carry many individual kill vehicles — much as a MIRV’d missile carries many RVS — resulting in some savings considering the cost of putting defensive vehicles into space in the first place. Multiple warheads on the same interceptor are impractical for use within the atmosphere, where the engagement timelines are too short to make multiple deployments feasible.

Preferential defense is a tactic for multiplying the effectiveness of a defensive system if it is only required to defend a subset of the targets under attack. For instance, suppose MX missiles were deployed amongst the six Minuteman wings and that survival of the missiles in two of these wings against a Soviet attack was considered a sufficient goal for the defense. The defense could then concentrate its exo interceptors upon destroying RVS targeted at the two defended wings and abandon the other four wings to the attacker. Which two wings were chosen for heavy defense could be kept secret from the Soviets or decided by the defense at the last minute. In their targeting planning, the Soviets would be unable to concentrate their RVS on the defended wings: they would either have to do their targeting as though all the wings were heavily defended or grant the defense its goal of two surviving wings. Adaptive preferential defense therefore effectively multiplies the number of defensive interceptors. In this example the Soviets would behave as though all six wings were defended as heavily as the two singled out by the United States. Adaptive preferential defense is not an effective tactic for endo systems because endo interceptors must be located near to the targets they are defending. The presence of the

defense near the defended sites therefore gives the game away.

### Infrared Sensing

An exo system that used large ground-based radars to acquire targets outside of the atmosphere could be blinded by direct attack or high-altitude blackout, and the view of ground-based optical sensors, which would be inadequate in any event, could be obscured by clouds and dust. It is therefore desirable to put the defensive sensors into space, either on the interceptors themselves or on other space vehicles. Space-based radars would be heavy, costly, and susceptible to jamming. For these reasons, many exo concepts employ spaceborne passive infrared sensors, which are relatively light and compact. However, infrared sensors are susceptible to offensive countermeasures such as decoys and other penetration aids.

### Layered Defense

Like endo systems, exo defense alone would be inadequate to defend a small number of targets against a large number of attacking RVS. In this case, the reason is not saturation of the defense, but the cumulative effect of leakage. It only takes one leaker to destroy a silo. If many RVS were aimed at each silo, the odds that one would get through could be high even if the probability that each individual RV was intercepted were high. The defense could attempt to stanch this hemorrhage of leakers by attempting to intercept each RV more than once (*assuming* that the multiple interceptor vehicles targeted at the same RV would not interfere with one another). This tactic could be effective but would drive the defense to enormous arsenals of interceptors.

If an endo defense were associated with each silo, the combined exo/endo Layered Defense would be more effective. The endo system could catch leakers from the exo system and, moreover, the exo system would improve the performance of the endo system since it would break up the concentrated,

structured attack patterns which saturate endo systems. Thus, exo (Overlay) and endo (Underlay) defenses in a Layered combination have a synergistic effect wherein the principal limitation of each is alleviated by the presence of the other. An endo defense could also help to protect the launch sites for the Overlay interceptors from a disabling precursor attack. It would also be difficult for an attacker to design decoys to confuse both the Overlay sensors *and* the Underlay sensors. However, since decoys are ineffective against low-altitude radar sensing anyway, an attacker would probably concentrate his penetration aids against the Overlay and not try to fool both layers. Last, the tactic of adaptive preferential defense for the Overlay loses some of its attractiveness when there is an Underlay because the Underlay cannot adapt: it can only defend the area (or individual silo) near which it is deployed. If the defense concentrates its Overlay resources on a subset of the silos and abandons the others to the attacker, then it leaves the endo defenses associated with the abandoned silos open to easy saturation and penetration. These endo resources—all bought and paid for—are wasted, whereas the whole purpose of adaptive preferential defense was to make optimum use of defensive resources.

### The Importance of overlay leakage

In contrast to low-altitude systems, which can accept relatively high leakage and still do a single-shot job, high performance is required of the Overlay component of a Layered Defense. Thus one must take seriously the many sources of leakage which can be present in the complex process of exo interception and also the possibility of having to face attacks involving decoys and other penetration aids. In practice, poor Overlay performance drives the defense to large inventories of interceptors in order to maintain a given level of silo survival. The effect of this sensitivity to Overlay leakage is best illustrated in the context of specific calculations. Such calculations are presented in the next section,

## The Overlay and Layered Defense of Silo-Based MX

### Overlay Description

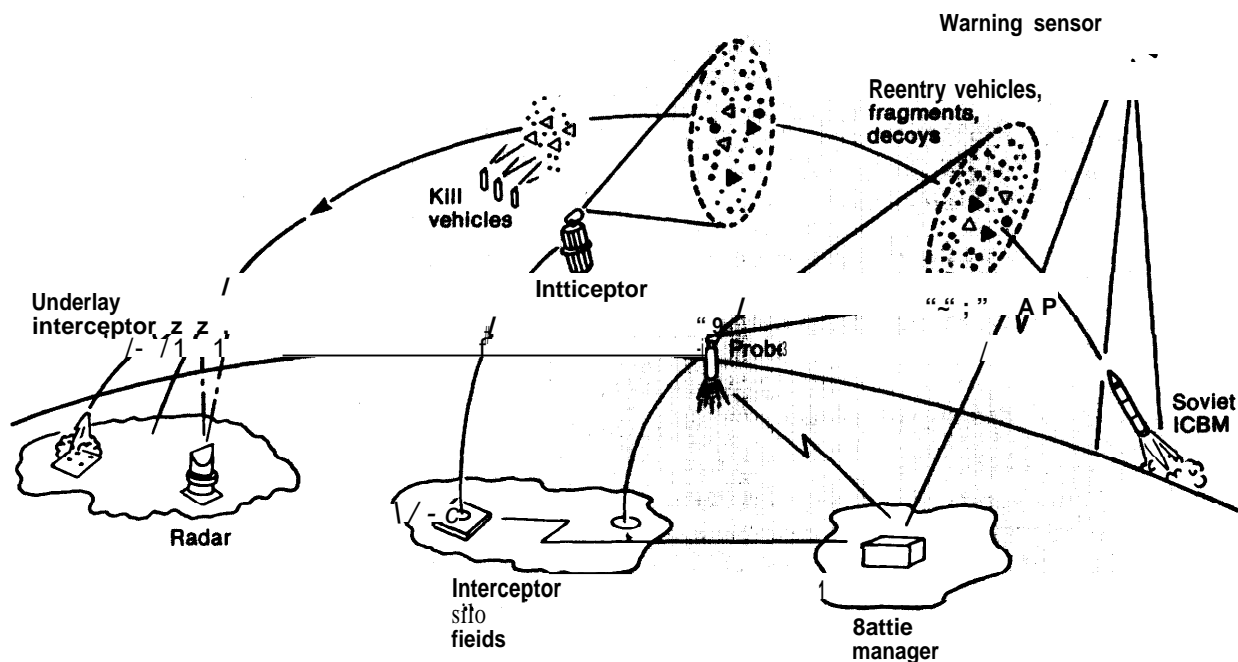
The Army's concept of the exo component of a Layered Defense — called simply the Overlay— is in the technology exploration stage. No detailed system design is available as exists for LoADS.

In outline (see fig. 62), the concept consists of interceptors roughly the size of offensive missiles equipped with infrared sensors and carrying several kill vehicles (KVS), also equipped with infrared sensors. The multiple KVS would be mounted on the upper stage of the interceptor. The interceptors, of which there might be several hundred, would be based in silos in the Central United States in the same manner as offensive missiles.

When attacking Soviet RVS were about two-thirds of the way through their flight to U.S. targets — about 10 minutes before impact — the interceptors would launch into space. When an interceptor reached space, its infrared sensor would scan its field of view and attempt to discriminate approaching RVS from tank and bus fragments and from decoys or other penetration aids. The infrared sensors would detect these objects as warm spots — warm since they were launched from the Earth — against the cold background of space.

Each KV would be assigned a target determined to be a true RV and dispatched to intercept it. Using its own rocket power and infrared sensor, the KV would home in on the object and destroy it either by colliding with it directly or by deploying a barrier of material in its path. Since the closing velocity of RV and

Figure 62.—Overlay/Underlay Layered Defense System



KV would be about 25,000 miles per hour, a small fragment of material from the KV could completely destroy the RV. Even a glancing blow could damage the RV'S heat shield, meaning that it would either burn up or be carried off-course as it reentered the atmosphere.

System studies of the Overlay concept have shown that performance would be improved dramatically by providing an additional sensor which would make an early assessment of the size and nature of the attack, allowing interceptors to be assigned more efficiently to regions of space. One idea for such a forward acquisition system (FAS) would be rocket-launched infrared sensing probes lofted into space as soon as warning sensors indicated Soviet launches. The probes would arrive on station within a few minutes and remain there for a short time before falling back to Earth. During this time, they would relay information on the trajectories of attacking RVS back to the interceptor silo fields. Since at any one time in the attack a number of probes would be required to cover all the attack corridors and their time on station would be limited, a longer lived FAS system might be required as well. This might consist of infrared sensors mounted on high-flying aircraft maintained on continuous alert and capable of several hours of time on station. Alternatively, satellites could perform an FAS function. However, neither of these longer lived FAS systems would be as capable as the probe.

The data acquired by the FAS would be integrated and interceptors assigned by a Central Battle Manager or by Wing Battle Managers associated with each set of defended silos. The battle managers would decide on a defense strategy and make interceptor assignments accordingly.

The battle managers and their data links would have to be immune to disruption by precursor SLBM attack.

Last, an exo defensive system would require early, secure, and reliable warning of Soviet attack. Systems to provide this warning must be considered part of the Overlay architecture.

## Risks to Overlay Effectiveness

The interceptors and kill vehicles, interceptor silos, FAS (probes, aircraft, or satellites), battle managers, and communications systems described above would comprise an extremely complex defensive system. The system architecture remains to be worked out in detail, and many technology issues are yet unresolved. In the absence of a detailed system design, it is not possible to analyze in quantitative detail the effectiveness and vulnerabilities of a Layered Defense system based on the Overlay in the way that such analysis is possible for LoADS. Analysis of the Overlay in the context of MX basing must instead rely on a qualitative estimation of technical risk and the sensitivity of Overlay performance to factors which are yet unknown.

As in the discussion of LoADS effectiveness, this section begins by asking how well the Overlay must perform in order to guarantee acceptable protection for silo-based MX missiles. Unlike a LoADS deployment with a single-shot goal, the effectiveness of a Layered Defense based on the Overlay is very sensitive to the details of system performance. One must therefore take seriously the uncertainties in overlay performance which exist at present. These uncertainties concern both the fundamental technologies in the Overlay concept and potential vulnerabilities in the working system as a whole. For the moment, facing the relative immaturity of the Overlay concept and a near-term decision regarding MX basing, it would be quite risky to rely on Layered Defense as the basis for ensuring MX survivability.

### THE IMPORTANCE OF LEAKAGE

"The ability of a Layered Defense to protect silo-based MX missiles against a massive Soviet attack depends sensitively on the performance of the Overlay component. For LoADS/MPS, by contrast, the defense would achieve a single-shot goal even if interception failed almost as often as it succeeded.

The effectiveness of a Layered Defense is a matter of probabilities, and the confidence of



attacker and defender to achieve their goals could depend not only upon the odds themselves but upon how willing either side would be to "play the odds" in a nuclear war. The discussion which follows is intended to be illustrative only: the precise numbers computed depend upon the assumptions and a myriad of details, but the overall trends, indicating the sensitivity to Overlay performance, do not. The assumptions made here tend to be rather favorable to the defense.

An illustrative silo basing arrangement for MX might consist of 200 MX missiles deployed in Minuteman III silos. The total U.S. ICBM force would then consist of 450 Minuteman III (one RV each), 350 Minuteman III (three RVS each), and 200 MX (10 RVS each, say), for a total of 3,500 RVS in 1,000 silos. In what follows it is convenient to take each silo to be a target of equal value, as though all missiles were identical and carried between three and four RVS. In actual fact, of course, the Soviets would be likely to target, and the United States to defend, MXs more heavily than Minuteman IIIs and Minuteman IIIs more heavily than Minuteman IIs.

Assume further that the Soviets deploy *no penetration aids* or alternatively that *discrimination is perfect*. This assumption concedes quite a bit to the defense, as the section on *Decoys and Other Penetration Aids* shows.

There is a certain probability that the Overlay will succeed in destroying an RV if it detects, tracks, and assigns a KV to it. Call this probability the "efficiency" of the Overlay; the leakage is one minus the efficiency. (It will be necessary to assume that the probabilities that individual intercepts succeed are statistically independent; this would not be true if, e.g., the KVS concerned originated on the same interceptor.) A quite respectable value for the efficiency in the absence of Soviet penetration aids would be 0.85 (85 percent); this value would assume achievement of all of the Overlay "specifications." A more modest value would be 70 percent, and so percent would be disappointing indeed. The point of this analysis is to show how strongly the number of U.S.

RVS surviving Soviet attack depends on Overlay efficiency.

The Underlay must also be specified. Here many choices are possible, ranging from a high-altitude Site Defense to simple single-shot "terminal" defenses. Assume that associated with *each silo* is a low-altitude defense with the capability to make a single intercept 70 percent of the time, a second intercept 50 percent of the time, and no capability to make three or more intercepts above the same silo. This constitutes a rather large and costly deployment and assumes effectiveness typical of low-altitude systems. A second intercept is allowed on the assumption that the second leaker could follow the first with a time delay.

For the Soviet arsenal, targeted against both MX and Minuteman, a range from 5,000 to 12,000 (reliable arriving) RVS could be considered; calculations will be done for a representative value of 8,000. Each arriving RV is assumed to have a single-shot kill probability of one.

If the Soviets had 8,000 RVS and no reason to target particular silos preferentially, they could direct 8 RVS at each silo, timed to arrive (if they penetrate the defense) within a short time of one another. If the Overlay has an efficiency of 85 percent, then the probability that *all eight* RVS aimed at a *defended* silo are destroyed by the Overlay is 0.85 to the eighth power or 0.27 (27 percent). The probability that one RV penetrates is the probability that seven RVS are intercepted (0.85 to the seventh power) times the probability that one penetrates (0.15) times the number of RVS (8) which have a chance to penetrate, for a total probability of 0.38 (38 percent). (The apparently paradoxical result that one RV penetrates more often than none reflects the fact that zero penetration can only occur one way, whereas single penetration can occur eight different ways.) The probability that two RVS penetrate is 24 percent.

Thus, 27 percent of the time the silo is safe because all RVS are destroyed in space. One gets through 38 percent of the time, but the

endo Underlay destroys this RV 70 percent of the time. Two RVS get through 24 percent of the time, but the first of these is destroyed 10 percent of the time and the second 50 percent of the time. Thus the overall probability that the silo survives is  $(0.27) + (0.7)(0.38) + (0.24)(0.7)(0.5) = 0.62$ , or 62 percent.

How many silos would actually be defended at all depends on the number of interceptors the United States deployed. For instance, if the United States deployed 400 interceptors with 10 KVS each, 500 silos could be defended against the 8,000-RV Soviet attack. Since 62 percent of the defended silos would survive, a total of 310 silos or 1,085 RVS would survive the attack. The Soviets would have expended 8,000 RVS to claim 2,415 U.S. RVS, and over 4,000 Soviet RVS would have arrived on the United States.

Suppose now that the Overlay efficiency were not 85 percent, but only 65 percent. The probabilities of none, one, or two RVS penetrating to the Underlay are then 3, 14, and 26 percent, respectively if the defense persists in directing one KV at each RV. The result that two RVS can penetrate more often than one reflects the fact that there are more pairs of RVS (28) than individual RVS (8). The higher probabilities for multiple leakers means that the endo defense has a harder job. In this case, only 22 percent of defended U.S. silos survive. If 4,000 KVS were used to defend 500 silos, the total U.S. survivors would be 110 silos or 385 RVS.

But this would not in fact be the best U.S. defense strategy if the Overlay efficiency were low. A better result would be obtained by defending half as many silos with twice as many KVS per silo, i.e., defending 250 silos and directing two KVS against each Soviet RV. This strategy would result in 70 percent survival of the 250 defended silos, for a total of 175 silos or 613 RVS surviving. The Soviets would again have paid 8,000 RVS, and over 6,000 RVS would have arrived on the United States. The Underlay defense at the 750 undefended silos would have been saturated.

In this example, a 20 percent degradation in Overlay efficiency (from 85 percent to 65 percent) results in the number of U.S. survivors being reduced by almost one-half. This effect demonstrates that the effectiveness of Layered Defense to protect silo-based missiles depends sensitively on the Overlay efficiency.

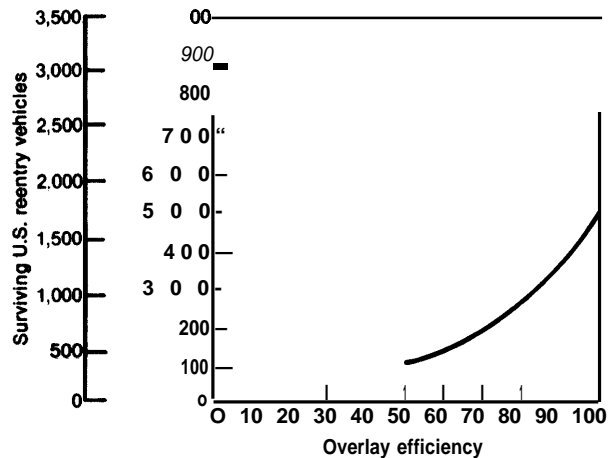
Figures 63 and 64 further demonstrate the importance of Overlay efficiency. Figure 63 shows that the number of U.S. survivors decreases dramatically as the Overlay efficiency degrades. Figure 64 shows that the size of the defensive arsenal needed to assure survival of 1,000 RVS (286 silos) quickly gets out of hand if the Overlay efficiency begins to slip. For a fixed number of U.S. silos the sensitivity to Overlay performance is more pronounced the larger the Soviet threat. For a fixed threat, the sensitivity is less pronounced the larger the number of U.S. aim points.

#### TECHNOLOGY ISSUES

Because of the sensitivity to performance described above, one must take seriously the uncertainties which exist at this stage of the

**Figure 63.—Sensitivity of Layered Defense Performance to Overlay Leakage**

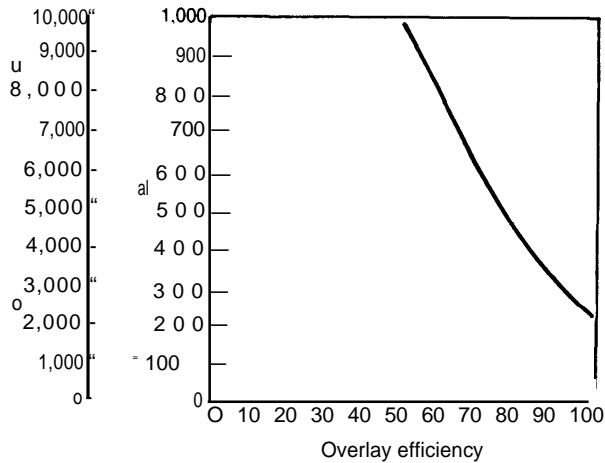
(Soviet attack consists of 8,000 reentry vehicles)  
(U.S. deploys 400 overlay interceptors)



SOURCE: Office of Technology Assessment

**Figure 64.—U.S. Defensive Arsenal Needed to Assure 1,000 Surviving U.S. Reentry Vehicles**

(Soviet attack consists of 8,000 reentry vehicles)



SOURCE Office of Technology Assessment

Overlay's development. Many aspects of the Overlay interception function require the frontier technologies of infrared sensor design, compact computer design, rapid computer throughput, software architecture, small homing and KV technology, and so on. The system requirements are demanding, and at all stages of the interception process advances must be made to meet them. Furthermore the stages are interlinked in such a way that failure at one stage could cause failures at others and degrade overall system performance significantly. There is no reason to believe that, given time and money, the uncertainties in Overlay technology could not be reduced to a point where a clearer estimation of the value of an Overlay system for the protection of silo-based missiles could be made. Nor is there any particular reason—with one exception, discussed in the section *Decoys and Other Penetration Aids*—to believe that fundamental technical problems will be encountered which by themselves would constitute "Achilles' heels" for an Overlay defense. Indeed, there is some reason for optimism, since the needed technology elements fall into categories—compact data processing, infrared sensing, miniature guidance systems, homing, etc.—in which rapid progress is occurring now and

more is expected in the future. Rather, the risk lies in the cumulative effects of shortcomings in the performance of technology elements at many stages of the interception process. In many cases the capabilities of today's technology falls short of the requirements of the Overlay by wide margins. Though progress can and should be expected, even small shortcomings could ultimately prove significant, since poor performance in one area can induce failure elsewhere, and the cumulative effect could be to reduce total system performance below the high standard required for MX defense. Technology forecasting is always risky, and in the case of the Overlay one is simply faced today with an unknown quantity. Though the level of confidence in Overlay technology may in time increase to the point where it could support a decision regarding MX basing, at the moment it appears quite risky to depend on successful resolution of all outstanding issues. The following discussion seeks to highlight unresolved technology issues and convey a sense of the complexity of exo defense.

The interception process begins when the probes or other FAS vehicles survey the attacking "threat complexes," the clusters of RVS, bus and tank fragments, and possibly decoys or other penetration aids, which are boosted into space by Soviet offensive missiles. In a large Soviet attack there would be tens of thousands of such objects in the sky. Each probe sensor should have as wide a field of view as possible so that a small number of them can survey the whole sky. But a wide field of view means either a large sensor, which is hard to protect from interfering background from the Sun, Earth, atmosphere, and other effects; or a slow scanning rate, which makes it difficult for the sensor to correlate what it sees on one scan with what it saw on previous scans, essential for discriminating RVS from other objects and for compiling accurate trajectory information. Unlike radars, infrared sensors cannot determine the ranges of distant objects but only their angular positions in the sky. Range must be inferred from changes in the angular positions of objects with time. Angular position must therefore be measured

very accurately, requiring precise orientation of the sensors in space. The threat complexes might also be rather dense: a single spot in the sky could later resolve itself into several objects. The probes must resolve all objects and observe them long enough to attempt to discriminate RVS from nonlethal objects and compute accurate trajectories. If all this is done poorly or too late, too many interceptors will be allocated to some regions of space and not enough to others.

The probes must then "handover" their files of objects to the interceptors, telling the interceptor sensors where to find each object and what it looks like. The interceptors must reacquire each object in their respective sectors, attempt discrimination again, and determine how best to release their KVS. Again, poor performance at this stage degrades performance at the next,

Last, the interceptor sensors must hand over targets to individual KVS. The KVS must then maneuver in such a way that they come within lethal range of an RV approaching at 25,000 mph. The KVS must also be able to distinguish the true RV from objects placed nearby. If the first intercept failed, a second wave of interceptors would have a very short time to perform all the required functions. It is not clear in any event that it would be possible to tell which intercepts had failed on the first attempt.

The infrared sensors are the most delicate element of the Overlay system. Infrared sensors can be disrupted by heat, nuclear radiation, and rocket exhaust gases. They would have to be mounted on very sensitive gimbal systems with accurate inertial guidance. Infrared sensors measure the temperature characteristics of approaching objects. These characteristics depend sensitively upon the position of the object relative to the Sun and Earth and on the time of day, season, and weather conditions on the Earth below. All of this data would have to be made available to the sensors before they could interpret what they saw. Infrared sensors of great sensitivity are also rather temperamental in that each behaves dif-

ferently and must be calibrated separately, and a given illumination of the same sensor can sometimes result in different output voltages. These latter factors introduce some fundamental limitations in temperature resolution, an important factor in discrimination.

#### SYSTEM ISSUES

In addition to the risk introduced by the high technology required, the Overlay as a system could have vulnerabilities much like the vulnerabilities of other basing modes. For instance, the Overlay would depend on tactical warning, since the system must begin to function early in the flight of Soviet ICBMS. The Overlay could thus share some of the potential vulnerabilities of other basing systems which depend on warning such as launch under attack and air mobile MX. The battle management function requires survival of the command centers and of secure, high-data-rate communications among the FAS, battle managers, and interceptor silo fields. The concerns here are similar to those regarding wartime survival of our national military C systems. Also, as with LoADS, attention must be given to offensive tactics designed to confuse or bypass the defense.

Limitations of the Overlay defense against submarine-launched ballistic missiles (SLBMS), which could attack the Overlay's own components, are discussed in the Classified Annex. Leakers from a precursor ICBM attack might also threaten critical system elements.

In the absence of a specific system design, it is again not possible to estimate vulnerabilities precisely. The interceptor silos and especially the probe silos would be few in number. Present Soviet SLBMS have limited silo-killing capability, and they are not normally deployed in large numbers near U.S. shores. Still, the Overlay defense assets would be high-value targets for an SLBM precursor attack, and depending on their hardness they could be vulnerable. Some thought has been given to providing an endo defense for the Overlay missiles themselves. Softer targets such as possible ground-based battle management

bunkers and their communications links could be vulnerable to less accurate SLBMS.

If strip-alert aircraft were used to supplement the probes or to serve as battle management centers, they would have the same vulnerabilities as the bomber force and Air Mobile MX. One must also consider an antisatellite threat if satellites were used to aid an FAS,

Care must also be taken to provide for survival of the high-data-rate communications linking FAS, battle managers, and interceptor fields. The generic technical problems of providing survivability for communications are similar to the case of launch under attack and to the C systems of other basing modes.

A complex defensive system like the Overlay must also reckon with offensive countermeasures. The most important of these is the use of penetration aids, discussed in the next section. Other tactics are discussed in the Classified Annex,

Detailed study of vulnerabilities at the total system level must wait until the Overlay concept is translated into a working design. Experience with the national military C' system and studies of launch under attack, air mobile MX, LoADS/MPS, and other basing systems give an idea of the scope of problems which can be encountered when a complex MX basing system faces a future Soviet threat. For the moment, the uncertainties in whether a robust wartime system can be fashioned from the Overlay concept are another source of risk to a decision to make Layered Defense the basis for MX survivability.

### Decoys and Other Penetration Aids

The Overlay concept is based on the practicality of infrared sensing in space. However, infrared sensing is potentially critically vulnerable to offensive countermeasures in the form of decoys and other penetration aids. Unlike the LoADS radar operating at low altitudes, which could measure the weight of approaching objects, the Overlay infrared sensors would measure their temperature characteristics. Decoys able to fool the LoADS radar

must be heavy, and adding heavy decoys to an offensive missile requires removing RVS, since the missile has limited throwweight. Measuring weight is therefore a strategically significant method of discriminating true RVS from decoys, since the offense would presumably not choose to offload RVS and replace them with equally heavy decoys. On the contrary, there is no impediment in principle to deploying lightweight decoys which have temperature characteristics indistinguishable from those of true RVS. Temperature, which is fundamental to the Overlay sensing method, is not a strategically significant discriminant. The offense might therefore be able to deploy a large number of excellent lightweight decoys on its offensive missiles without having to offload many RVS. This would call into question the effectiveness of an exoatmospheric defense of MX.

This section will indicate some of the elementary physical principles that permit the design of lightweight penetration aids. It will also indicate the practical difficulties which the offense would face in mounting decoyed attacks as well as those the defense would face in countering them. A more complete discussion is relegated to the Classified Annex.

To get a feeling for the importance of discrimination, consider the case if the offense provided along with each RV a single *perfect decoy*. A KV approaching the two objects would then intercept the true RV 50 percent of the time. If the efficiency of the defense, as defined in the last section, were 85 percent in the absence of decoys, and if one KV were dispatched against each RV/decoy pair, then the true RV would be intercepted only  $(0.85)(0.5) = 43$  percent of the time. This low efficiency (high leakage) would be catastrophic to the defense, as figures 63 and 64 in the previous section show. If on the other hand the defense directed a KV at both the RV and the decoy, then the same number of U.S. silos would survive as in the no-decoy case, but an arsenal of defensive missiles twice as numerous would be required to produce this result.

In practice, no decoy is perfect, and on the other hand the offense could deploy many

more than one decoy with each RV. In practice also, a tradeoff is made between leakage (intercepting the object judged most likely to be an RV and allowing an RV to penetrate if the guess is wrong) and wastage (intercepting everything). In the case of the Overlay, the need to keep leakage low means that the best solution for the defense is usually to accept high wastage. Thus, an offensive decoy deployment would tend to drive the defense to larger numbers of defensive interceptors — in the example above, applied to the model in the last section, twice as many, or almost as many defensive missiles as offensive missiles.

#### INFRARED SENSING AND TEMPERATURE

A metal bar heated to very high temperatures glows white-hot. If its temperature is lowered somewhat, it glows red-hot. If cooled further—to room temperature—it no longer glows in the visible part of the spectrum but at longer wavelengths, in the infrared part of the spectrum. A room-temperature object thus “glows infrared” and can be “seen” by a detector sensitive to infrared light.

An RV launched into space from the approximately room temperature condition of its silo forms a glowing spot against the dark (i.e., cold) background of space. Infrared sensors can measure both the color (i. e., the precise shade of infrared light) and the brightness of the RV and of any other objects, such as decoys, which accompany it. The color of the object reveals its temperature and its brightness reveals its size and the type of material it is made of. Decoy/RV combinations that appear to the infrared sensors to have identical color and brightness cannot be discriminated.

In addition to the warmth it brings with it from the Earth, the object absorbs energy from the Sun above and the Earth below and loses energy to cold space. Its color could therefore change as it were warmed or cooled. In addition to emitting light because of its temperature, the object also reflects infrared radiation from the Earth. An infrared sensor therefore senses the combination or sum of the emitted and reflected energy from the object.

There is a relationship between the tendency of a body to emit thermal radiation because of its temperature and its tendency to reflect radiation which shines on it. For a body of a given size (more precisely, surface area) at a given temperature, the *sum* of its effectiveness in emitting radiation of a given wavelength and in reflecting it is the same no matter what the body is made of. Therefore, the less infrared radiation a body in space emits, the more it reflects from the warm Earth and vice versa. The relative emittance and reflectance

does depend on the nature of the body, but only on what the *surface* of the body is made of and not what is inside it.

Using only these elementary principles of physics, it is a straightforward matter to design RV/light-decoy pairs which appear identical to infrared sensors. A wide variety of other examples of penetration aids based on simple thermal properties of materials can also be designed. These are discussed at some length in the Classified Annex.

#### MEASURE AND COUNTERMEASURE

In practice, the situation is more complex than simple physical principles alone would indicate, with many constraints and opportunities both for the offense and the defense. Despite these complexities, the fact remains that there is no principle and no detector that could guarantee perfect Overlay discrimination. The burden would thus rest with the defense to maintain its confidence that its methods of discrimination were adequate to meet a decoy threat.

To begin with, there would be practical constraints on the offense. Foremost among these is the fact that the best results would be obtained by altering the RV to make it easier for a light decoy to match. Though these changes are minor, inexpensive, and need not affect RV performance in the least, there could be some psychological reluctance to tamper with the lethal RV for the sake of a nonlethal decoy. It is also one thing to design the perfect decoy and quite another to package it, mount it on an ICBM, and deploy it in space so that its

deployment process and in-flight motions (*assuming* these could be observed by the defense in an attack) resemble those of a true RV.

Constraints on the defense include the fact that infrared sensors are not perfect (i. e., cannot determine brightness and temperature precisely, especially in the presence of background) and they would not have a very long time to observe objects in an engagement. The temperature characteristics of objects in space furthermore depend on the position of the Sun and Earth relative to the sensor and the time of day and weather conditions on the Earth below. Overall, the interception process is difficult enough even in the absence of decoys, as discussed in the last section.

Since there is no fundamental principle on which infrared sensors can rely to guarantee discrimination, there could be value in some advance knowledge of the type of penetration aids the offense deployed. It is possible (likely is too strong a word) that by observing flight tests, the defense could learn enough about the offense's penetration aids to devise a dis-

crimination scheme based on some distinctive feature or detail of the offense's design or deployment procedure. However, since there appears to be a wide variety of effective penetration aids which the offense could use, this approach based upon particulars rather than principles could succeed for one penetration aid but fail for another.

Details and further discussion of penetration aids, constraints, and tactics can be found in the Classified Annex.

Overlay discrimination is a difficult problem, the practical details of which are not understood, though the principles are. Testing of penetration aids designed expressly *and exclusively* for the purpose of Overlay penetration is required before it can be known whether the perfect decoy of principle can be realized in practice and whether less-than-perfect decoys still make defense based on infrared sensing too difficult and costly to undertake. For the moment, the very fact that effective decoys are possible counsels caution.

## HISTORY OF BMD AND THE ABM TREATY

The development of ABM systems by the United States in the early 1950's followed the decision to begin development of ICBMS. During the mid-1960's, the Johnson administration proposed the deployment of the so-called Sentinel ABM system to provide both area and point defense against a limited nuclear attack. This proposed ABM system was reviewed in 1969 by the Nixon administration which opted instead for an ABM system to defend Minuteman silos. Deployment of the Nixon administration's Safeguard ABM system was begun in the early 1970's but was brought to a halt following negotiation and ratification of the ABM Limitation Treaty of 1972. The Treaty was subsequently amended by the Protocol of 1974.

With the development of ballistic missile defense, doubts about the long-term viability of international security based on a "balance

of terror" began to mount. While alternatives to maintaining a balance of terror were explored through a variety of formal and informal channels, by the mid-1960's it seemed to many senior U.S. policy makers that some sort of arms limitation on ballistic missile defenses would be preferable to either an ABM arms race or a major revision in the post-World War II "balance of terror".

For example, Defense Secretary Robert S. McNamara noted:

Should they elect to do so, we have both the leadtime and technology available to so increase both the quality and quantity of our offensive strategic forces—with particular attention to highly reliable penetration aids—that their expensive defensive efforts will give them no edge in the nuclear balance whatever.

But we would prefer not to have to do that. For it is a profitless waste of resources, pro-

viald we and the Soviet can come to a real istic strategic arms-limitation agreement.

Even though Secretary McNamara had serious reservations about ABM systems in general, he nevertheless proposed to deploy an ABM system to defend the United States against some nuclear attacks. The Sentinel ABM system proposed by the Johnson administration included a long-range, high-altitude exoatmospheric interceptor missile, the Spartan, guided to targets by a very large radar and a smaller, shorter range interceptor missile, called Sprint, also guided to its targets by radar. Both missiles were armed with nuclear warheads which destroyed incoming reentry vehicles. The original Johnson administration proposal envisioned deployment of the Sentinel ABM System at some 14 sites including ICBM silo fields in Montana and North Dakota as well as several major cities.

The Nixon administration reviewed the proposed Sentinel ABM system in light of both U.S. strategic requirements and the intense political opposition that arose over the potential deployment of nuclear weapons adjacent to American cities and concluded that the use of Sentinel radar and interceptor components to defend U.S. Minuteman fields would be an appropriate and strategically significant response to the Soviet deployment of an ABM system around Moscow. On March 14, 1969, President Nixon announced his plan to deploy an ABM system to defend ICBM silos in Montana and North Dakota:

This measured deployment is designed to fulfill three objectives:

1. Protection of our land-based retaliatory forces against a direct attack by the Soviet Union
2. Defense of the American people against the kind of nuclear attack which Communist China is likely to be able to mount within the decade,

3. Protection against the possibility of accidental attacks from any source.<sup>2</sup>

At the same time, the United States undertook the preparations for the formal beginning of bilateral arms control negotiations with the Soviet Union for the purpose of limiting both strategic offensive and defensive weapons, seeking to obtain international security through balanced limitations on strategic arms, as well as the procurement of additional strategic offensive and defensive weapons.

### The ABM Limitation Treaty

After more than 3 years of intense negotiations on strategic arms limitation, the United States and the Soviet Union concluded the SALT I agreements in 1972. Two agreements were concluded by President Nixon and General Secretary Brezhnev in May 1972. The first of these was the ABM Limitation Treaty; the second was the Interim Agreement on Strategic Offensive Arms. In 1974, the United States and the Soviet Union agreed to an amendment to the ABM Limitation Treaty further limiting the deployment of ABM systems.

At the time the ABM Limitation Treaty was negotiated, there was a general belief that the available ABM technology was not very effective. The Sentinel ABM System technology incorporated into the Safeguard system had several technical deficiencies. Radar data processing with available computer technology was limited in terms of number of targets that could be tracked and the number of interceptor missiles that could be guided to targets. The use of nuclear weapons to defend targets under attack could have blacked out the ABM radars, preventing them from detecting and tracking targets passing through the disturbed region. In addition, the number of interceptor missiles planned for deployment was so small that an adversary could easily attack the ABM system with a large number of reentry vehicles, thereby exhausting the defense.

<sup>1</sup>Address by Secretary of Defense McNamara to United Press International Editors and Publishers, Sept. 18, 1967," in U.S. Arms Control and Disarmament Agency, *Documents on Disarmament, 1967* (Washington, D.C.: U.S. Government Printing Office, 1968), p. 385.

<sup>2</sup>Statement by President Nixon on Ballistic Missile Defense System," in U.S. Arms Control and Disarmament Agency, *Documents on Disarmament, 1969* (Washington, D.C.: U.S. Government Printing Office, 1970), p. 103.



In general, the ABM Limitation Treaty of 1972, as amended by a Protocol negotiated in 1974, prohibits ABM systems based on the technology deployed by the United States and the Soviet Union in the late 1960's and early 1970's. The Treaty as amended does permit each side to deploy one ABM system for defense of either its national capital or an ICBM silo field. The Treaty also permits continued research and development on allowed ABM systems, bans other types of ABM development, test, and deployment, and provides for further negotiations on specific limitations of new ABM systems based on technologies not deployed in the 1970's.

Article I of the Treaty prohibits ABM system deployments other than those specifically permitted by subsequent articles of the Treaty. Article II defines ABM system components. Article II 1, paragraph (b), permits the United States to deploy one ABM system with the following characteristics:

- not more than two large phased-array ABM radars,
- not more than 18 small phased-array ABM radars,
- not more than 100 ABM interceptor launchers and not more than 100 ABM interceptor missiles in a deployment area having a radius of less than 150 kilometers centered on the middle of an ICBM silo field.

Article IV of the ABM Limitation Treaty permits its development and testing of ABM components at designated test ranges without counting such components in the quantitative limits established in article II 1,

Article V of the Treaty bans the development, test, or deployment of sea-based, air-based, space-based, or land-mobile ABM systems or components. Article V also bans the development, test, or deployment of ABM interceptor launchers which contain more than one interceptor or which are capable of automatic or semiautomatic interceptor reload.

<sup>1</sup>"The ABM Limitation Treaty," in U.S. Arms Control and Disarmament Agency, *Arms Control and Disarmament Agreements, 1980 Edition* (Washington, D.C.: U.S. Government Printing Office, 1980), p. 140

Other official statements incorporated into the legal restrictions of the ABM Limitation Treaty also affect future ABM system development, test, and deployment. Agreed statement (D) contains the following provision:

In order to insure fulfillment of the obligation not to deploy ABM systems and their components except as provided in Article II 1 of the Treaty, the Parties agree that in the event ABM systems based on other physical principles and including components capable of substituting for ABM interceptor missiles, ABM launchers, or ABM radars are created in the future, specific limitations on such systems and their components would be subject to discussion in accordance with Article XI 1 and agreement in accordance with Article XIV of the Treaty.

Agreed statement (E) prohibits deployment of ABM interceptor missiles with more than one independently guided warhead.

The ABM Limitation Treaty Protocol negotiated in 1974 and ratified in 1976 further amended the ABM Limitation Treaty in the following respects. Article III of the Treaty originally permitted both the United States and the Soviet Union to deploy two ABM systems in two deployment areas. One permitted system could defend an ICBM silo field; another could defend the national capital. Article I of the 1974 Protocol limits each side to only one ABM system deployment.

Article I 1 of the Protocol permits each side to shift deployment of its permitted ABM system once. In the case of the United States, the protocol would permit the dismantling and destruction of the ICBM silo ABM defense system at Grand Forks and the relocation of the ABM system to the Washington, D.C. area.

### Application of ABM Treaty Provisions to MX Defense

ABM systems deployed to defend MX are limited by the ABM Limitation Treaty of 1972 (as amended by the 1974 Protocol) in two distinct ways. First there are limitations on the deployment of ABM systems. Second, there

<sup>1</sup>*ibid*, p 143

are limitations on the development of new ABM systems.

ABM deployments are limited by the ABM Treaty as amended in the following respects:

- 1 any U.S. ABM system may only be deployed in a circle of 150-km radius centered on the Grand Forks, N. Dak., ICBM field;
- 2 LoADS defense units could not be deployed if any system component were explicitly not of a fixed type;
3. since each LoADS unit would contain one small radar, no more than 18 LoADS DUS could be deployed under terms of the radar limitations of the ABM Treaty;
- 4 the total number of LoADS or Overlay ABM interceptor launchers and ABM interceptor missiles could not exceed 100;
5. LoADS defense units could not be deployed if each unit contained more than one ABM interceptor launcher. Alternatively, even if each LoADS defense unit contained only one interceptor launcher, it would still possess in principle automatic, semiautomatic, or rapid reload capability, barred by the Treaty;
- 6, since each Overlay KV is an independently guided warhead within the meaning of the Treaty, deployment of more than one such warhead on each Overlay interceptor missile would be prohibited under provisions of agreed statement (E).
7. deployment of space-based laser ABM systems is explicitly prohibited by article V of the ABM Treaty,

The development of future ABM systems is also limited under terms of the ABM Limitation Treaty. The United States and the Soviet Union have defined development of ABMs for purposes of the Treaty as follows:

The obligation not to develop such systems, devices or warheads only to that stage of development which follows laboratory development and testing, The prohibitions on development contained in the ABM Treaty would start at that part of the development process where

field testing is initiated on either a prototype or bread-board model.<sup>5</sup>

Thus, the following limitations would apply to the development of specific ABM systems such as LoADS, Overlay, or even space-based ABM systems:

1. mobile components of ABM systems developed beyond the laboratory such as LoADS defense units would be banned;
2. multiple independently guided KVS for the Overlay could not be tested beyond the confines a laboratory;
3. development of unique components for spaced-based laser ABM systems would be banned.

### Future ABM Limitation Negotiations

The ABM Treaty provides that either side may propose amendments during semiannual meetings or special meetings of the Standing Consultative Commission which was established to resolve questions of interpretation in the Treaty as well as to supervise and resolve questions of verification. The 1974 Protocol amending the Treaty arose out of just such Standing Consultative Commission discussions. The Treaty, which is of unlimited duration, also provides for a formal review conference every 5 years at which time either side may propose changes or amendments. The next ABM Limitation Treaty Review Conference is scheduled for October 1982.

Present ABM options for the defense of MX deployments are significantly constrained by the Treaty from the standpoint of final engineering. Substantial research on new ABM systems can be undertaken, and development and testing of ABM components whose purpose is to modernize the mothballed Safeguard system can also be undertaken, New radars, new interceptors, and new warheads

<sup>5</sup> Ballistic Missile Defense, \* in U S Congress, House Committee on Foreign Affairs and Senate Committee on Foreign Relations, *Arms Control Impact Statement for FY82/Year 1982* (Washington, D C U S (government Printing Office, 1981, p 195

for Safeguard are all testable and deployable under terms of article VI I of the Treaty permitting modernization of existing ABM systems. Even development of directed energy weapons for possible use as ground-based ABM systems would be permitted under terms of the Treaty, so long as deployment as modernization for the Safeguard system was envisioned.

The United States might wish to explore the possibility of further amending the ABM Limitations Treaty in a manner that would permit engineering development and possible deployment of the LoADS or Overlay ABM system as they are presently envisioned during the course of the 1982 ABM Limitation Treaty Review Conference. Reopening discussions of the substantive provisions of the ABM Limitation Treaty does, however, raise serious questions in need of further analysis beyond the scope of the study.

The process of renegotiating the ABM Limitation Treaty is subject to uncertainty. The Soviets, too, have an active ABM research and development program which is also constrained by the ABM Limitation Treaty. Modifications in the terms of the ABM Limitation Treaty which would permit the United States to proceed with development and testing necessary to advance the LoADS ABM technology into engineering and full-scale engineering development, or permit development of Overlay technology, would also permit comparable developments in the Soviet ABM program.

Hence judgments of the technical, political, and military benefits to be gained by reopening negotiations on ABM I imitations will have to be made should some basing mode for the MX missile requiring ABM systems be contemplated.

**Chapter4**

# LAUNCH UNDER ATTACK

# Chapter 4.- LAUNCH UNDER ATTACK

	Page
Overview of Rationale for LUA and Possible Drawbacks . . . . .	147
Possibilities for LUA Systems. . . . .	148
Targets and Military Utility . . . . .	149
Timelines. . . . .	150
Overview of Technical Requirements . . . . .	150
Early Warning and Attack Assessment Systems. . . . .	151
Command Posts. . . . .	154
Communications Links. . . . .	154
Pindown. . . . .	156
Procedures. . . . .	156
Operational Possibilities for LUA . . . . . ; . . . . .	159
Illustrative Soviet ICBM Attack on U.S. Silos Only. . . . .	159
Illustrative Soviet ICBM/SLBM Attack on U.S. Silos and LUACapability Excluding Washington. . . . .	160
illustrative Soviet ICBM/SLBM Attack on U.S. Silos, Other Military Targets, LUACapability, and Washington. . . . .	161
Attempt to Disrupt U.S. Technical Capability to LUA Precedes Soviet Attack . . . . .	161
Summary of Critical Issues for LEA. . . . .	162
information Available to Decisionmakers. . . . .	163
Decision Timelines. . . . .	163
Possibilities for Diplomatic and Other Activities. . . . .	163
Providing for Launch Authority . . . . .	163
Fear That U.S. LUACapability Could Somehow Be Sidestepped . . . . .	164
Risk of Error. . . . .	164

## LIST OF FIGURES

Figure No.	Page
65. Attack Timeline. . . . .	150
66. Launch-Under-Attack System Architecture . . . . .	151

Another approach to MX survivability is to accept vulnerable silo basing and resolve to launch silo-based MX missiles before attacking Soviet reentry vehicles (RVs) could arrive to destroy them. This type of response to a Soviet attack is called launch under attack (LUA). Adopting this approach to MX survivability would imply relying on LUA as opposed merely to preserving it as a possibility. The United

States now preserves the capability to LUA as a matter of stated doctrine. Some, though not all, of the other basing modes described in this report would also allow this capability to be preserved. This chapter does not in any way address the present U. S. doctrine or the status of means to support that capability, but only potential future systems of reliance on LUA.

## OVERVIEW OF RATIONALE FOR LUA AND POSSIBLE DRAWBACKS

The chief attraction of LUA basing is that it can be implemented faster and more cheaply than other basing modes since there is no basing "mode" to speak of. The United States could in principle put MX missiles in the Minuteman silos as they came off the assembly line, meaning MX deployment in the second half of this decade. However, some of the hardware needed to support the LUA capability (warning sensors, communications links, and the like) might have longer lead-times. A truly robust and dependable system might therefore take slightly longer to deploy.

Even with a wide range of sophisticated, redundant support hardware—just about everything one could think of buying in the way of sensors and communications—the price of an LUA system (excluding the missiles themselves) would come to billions of dollars rather than tens of billions as for other basing modes. Some of the systems required for LUA would in fact be desirable, perhaps even necessary, to deploy with *any* basing mode.

This hardware—warning sensors, command posts, and communications links—could be made virtually impossible for the Soviets to destroy or disrupt. What cannot be assured with confidence is that competent National Command Authorities (NCA) would in all circumstances have access to this system in the short LUA timeline; this is essentially a matter

of procedures and national policy, not technology.

Because already-existing silos (or a small number of new ones) could be used, there would be little new construction and hence little environmental and societal impact.

LUA would preserve familiar features of silo basing, including weapon effectiveness as measured by accuracy, time-on-target control, and the like; familiar force management procedures; and familiar arms control verification procedures.

From the point of view of strictly military utility, the possibilities for an LUA force differ very little from those available to a survivable force. The same targets (and perhaps more) would be available in the first few minutes of a war as in the first few hours or days. Essentially the same targeting flexibility could be provided with technically feasible hardware.

Reliance on LUA also has potentially serious drawbacks.

Depending on the circumstances, decision-makers could lack crucial information regarding the extent and intent of the Soviet attack—information necessary to gauge the proper response. It is not clear, however, that much better information would always be available to the commander of a survivable force within a short period after a nuclear attack.

Decisionmakers would also lack an interval between attack and response during which intelligence information could be assessed, diplomatic measures considered, and the intent of the U.S. response signaled — assuming the circumstances of nuclear war permitted such things at all.

Decision time would obviously be very short. NCA would have to make unprecedentedly weighty decisions in less than 15 minutes.

To guarantee the LUA capability against some contingencies it might be necessary to

adopt unpalatable procedures regarding, for instance, delegation of launch authority.

No matter how much money and ingenuity were devoted to designing safeguards for the U.S. capability to launch under attack, and even if the safeguards were very robust indeed, it would probably never be possible to eradicate a lingering fear that the Soviets might find a way to sidestep them.

Finally, despite all safeguards, there would always remain the possibility of error, either that missiles were launched when there was no attack or that they failed to launch when the attack was genuine.

## POSSIBILITIES FOR LUA SYSTEMS

There is a wide variety of possibilities for LUA systems, and which is “best” is not really a matter of technology but of doctrine, procedures, and national policy. Doctrine determines the types of attack which the system is designed to meet and those which it is not. For instance, it would be easier to configure an LUA system on the assumption that a Soviet attack would be directed at missile silos and perhaps other military targets but would not be preceded by attack on Washington. If Washington were attacked first, an LUA system designed on this assumption might fail. But since the intercontinental ballistic missile (ICBM) vulnerability problem is perceived generally within the context of counterforce attacks excluding U.S. cities, it is not clear that an LUA force must be required to meet such a contingency; in this case it might be thought that an appropriate response could be executed with surviving submarine, cruise missile, and bomber forces. These are clearly issues of doctrine. Regarding procedures— and to take a more extreme example— it would also be easier to design an LUA system on the assumption that launch authority were vested in certain circumstances in persons other than the President and other duly constituted NCA or even that the response to be made to a Soviet attack of a given sort were decided in

advance and, so to speak, “wired into” the ICBM system.

Doctrine and procedures — issues of national policy, not technology— more than anything else therefore determine the architecture of an LUA system.

This section outlines the *technically feasible* hardware elements and procedures that could go into an LUA system. It seeks to give a sense both of the breadth of possibilities and of the fundamental limitations. The next section shows how some of these elements might come into play in the circumstances of a Soviet attack. It should be emphasized that what is being described here are elements of a *hypothetical future* LUA system, *not* means which support the present U.S. LUA capability.

The principal elements to analyze from the technical point of view are targets and the military utility of an LUA force, the timelines of possible attacks, early warning and attack assessment systems, command posts, and communications links. Possible procedures by which decisions could be made and launch orders given can be laid out, but a selection among them would be a decision for the highest levels of political authority.

## Targets and Military Utility

The first question to ask of an LUA force is whether there are important and identifiable differences, in terms of the military effectiveness of a U.S. response to Soviet attack, between immediate LUA response and a delayed response executed by a survivable force. Though there are some differences, on balance it appears that little or nothing from a purely military point of view is sacrificed by immediate response,

In the first place, there would seem to be no targets which would be absent or untargetable early in the war but which would somehow appear later on. Thus, there can be from this point of view no disadvantage to retaliating immediately; on the contrary, it would seem that a difference between early and delayed response, if one were to exist, would favor the early response. The most stressing case for an LUA system is one in which the Soviet attack came with no indications of preparation for attack before the actual launch of Soviet missiles. In this case, a prompt U.S. response could destroy other Soviet military assets before they had time to disperse from their ordinary operating bases. If the Soviet attack came from a generated posture, some assets might be difficult to target, but this situation would not necessarily improve with time. Even if there were significant Soviet target complexes that “appeared” later, it is unlikely that they would be hardened to such an extent that their destruction would require ICBMS, although if they were mobile a rapid response-time for U.S. attack could be useful. Such rapid response is most easily accomplished with ICBMS. Even assuming the existence of targets which a survivable force could target but an LUA force could not, one must assume in addition that the U.S. intelligence assets required to locate these targets would survive an initial Soviet attack.

As to the nature of the targets that should be assigned to an LUA MX force, the important issue for this purpose is not what these targets might be, but how the selection might differ from those assigned to a survivable retaliatory

force. Again, there do not appear to be significant differences. In either case, the actual targets attacked might well depend upon the nature of the Soviet provocation and have the goal of inflicting on the Soviet Union a level of damage — measured overall — commensurate with the damage anticipated from the Soviet attack, as well as the latter could be judged at the time the U.S. decision to respond had to be made. If Soviet silos were among the targets marked for destruction by the LUA force, one might want to have some means for determining which were still full and which empty, and one would also have to take the chance that the Soviets would themselves launch under attack when our missiles were in flight. Both problems exist for a survivable force as well. In practice it is likely that the same information, obtained at launch, would be used to support retargeting to avoid attacking “empty holes” whether by survivable or LUA forces; the only difference would be the retargeting time available. In practice it is also possible to guess in advance which Soviet missiles would be used in an attack on U.S. silos. There is also an analytical basis upon which to question the utility of bothering with any sort of “empty hole” retargeting. (It might even be thought desirable to attack empty holes to preclude “reload,”) As to Soviet LUA, with a survivable force there would be a time delay before retaliation during which efforts could be made to destroy Soviet sensors capable of indicating a U.S. launch.

Since decisions would have to be made quickly, and since extensive ad-hoc retargeting would be difficult to carry out in the short LUA timeline, some preplanning would have to be done regarding the responses to be made to a given Soviet attack. Such preplanning would also be done for survivable forces. To the objection that such preplanning is unpleasant or “commits” the United States to certain types of response, it can only be noted that the concept of deterrence presupposes, independent of the forces concerned, that Soviet attack will provoke with high certainty a U.S. response. Whether the United States would *actually* choose to retaliate if deterrence failed cannot



be said on the basis of the forces deployed. Of course, LUA allows little time for reflection if Soviet attack did occur.

There might be no need to have the *entire* U.S. ICBM force postured for LUA. Since a *survivable* force of, say, 1,000 RVS might be considered adequate for a delayed response, no more than this number of RVS need be included in the force which “survives” by launching under attack.

### Time lines

Soviet ICBMS take about a half hour to make the journey from their silos to U.S. ICBM fields in the Central United States. The time from first launch to first impact could in principle be shortened by a small amount, but this would be likely to cause some degradation in accuracy. A realistic Soviet laydown would also occur over a span of time, from just under 30 minutes until somewhat later.

Speaking roughly, receipt of the launch message or Emergency Action Message (EAM) by the missile force as late as a few minutes before Soviet RVS arrive would be sufficient to guarantee safe escape of the missiles. This brief time period would be accounted for by the time taken for the EAM to be transmitted to the missile fields, decoded, and authenticated; the time taken to initiate the launch sequence; the time from first missile takeoff to last; and the time needed for the last missile to make a safe escape from the lethal effects of the incoming Soviet RVS.

Thus, the time available for ICBM attack assessment and decisionmaking” would be the half-hour ICBM flight time minus this small time period for missile launch.

Soviet submarine-launched RVS targeted at command posts and communication nodes could arrive earlier than the ICBMS. It is assumed here that the Soviets would not possess submarine-launched ballistic missiles (SLBMS) deployed near U.S. coasts of sufficient accuracy and in sufficient numbers to constitute themselves a primary threat to U.S. silos. Forward-deployed SLBM RVS could ar-

rive in the Central United States within 8 to 15 minutes of launch and at coastal targets, such as Washington, within 5 to 10 minutes. This means that relatively soft targets such as command bunkers and communications nodes, if targetable, could be destroyed early in the attack. One of the principal goals of a robust LUA system must be to survive such a precursor SLBM attack in order to support execution of a launch decision,

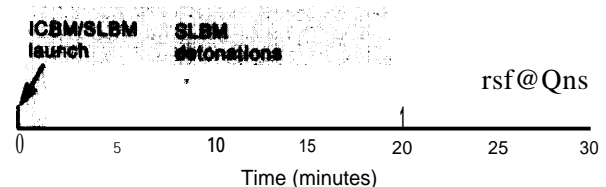
Assuming simultaneous launch of Soviet ICBMS and SLBMS, the timetable which results is shown in figure 65.

The LUA timetable could be extended somewhat by a “dust defense” such as described in chapter 3. In this scheme, the dust cloud formed by deliberate detonation of buried nuclear weapons in the silo fields would destroy the first wave of Soviet RVS. The United States would have until the dust cleared — tens of minutes — since a second attack could not be mounted during this time.

### Overview of Technical Requirements

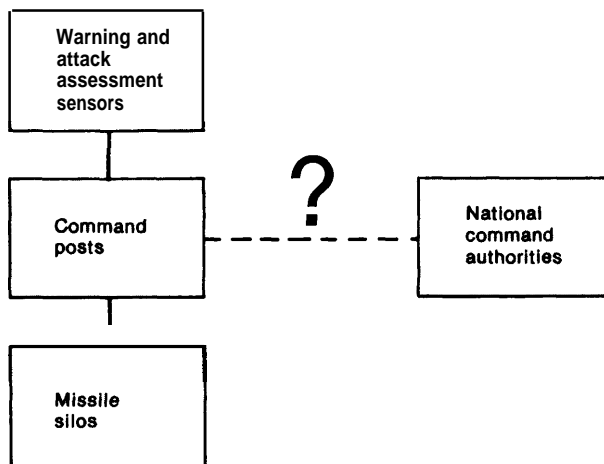
In order to meet the timeline and attack constraints outlined above, a U.S. LUA capability would require warning and attack assessment sensors impervious to disruption; survivable command posts to digest and organize sensor information; and secure, reliable communications linking the command posts with the warning sensors and with the missile fields. The most important requirement, and the most difficult to meet in practice, would be providing a connection from the survivable command posts to NCA empowered to make launch decisions. This architecture is shown in figure 66.

Figure 65.—Attack Timeline



SOURCE Office of Technology Assessment

**Figure 66.— Launch-Under-Attack System Architecture**



SOURCE Office of Technology Assessment

The paragraphs below indicate the range of technically feasible candidates for these system elements. It will be apparent that no single element can be made survivable against a determined Soviet effort to disrupt it. One must instead make disruption as difficult and time-consuming as possible, provide redundant backup systems, and seek to make price of disruption so high that Soviet attack on all U.S. LUA assets would virtually be cause itself to retaliate against the Soviet Union.

### Early Warning and Attack Assessment Systems

The important features of warning and attack assessment systems are when in the course of an attack they could be expected to provide information, what information they could furnish at that time, and how *difficult to disrupt* they would be. In general, the first two features are related in that the more complete the information they furnish, the later in the attack they do so. Timely information concerning the size and character of the attack would be vital to the confidence a decision maker could have in his judgment to fire U.S. nuclear weapons at the Soviet Union. There would be a premium upon confirmation of the facts of the

situation from as many sources as possible. For this reason it is desirable to have sensors based on a variety of distinct physical principles.

The following paragraphs outline in general terms the important features of a wide range of warning and attack assessment systems that the United States could deploy to support LUA. Since even in aggregate the cost of these systems would be less than the costs of other MX basing modes, it is not inconceivable that the United States would deploy all of them and more.

### Satellites

The booster motors of large ballistic missiles, which operate for some minutes after launch, emit huge amounts of power (hundreds of kilowatts) in the short-wave infrared portion of the electromagnetic spectrum. This radiation could be detected by satellites at very great distances from the earth. It would be virtually impossible for the Soviets to conceal this evidence of their attack.

Such satellites could provide an accurate count of the number of launches, the types of missiles launched (from comparing the brightness of their infrared emission to data from test launches), and at least the approximate (wing level) locations of the launch points. This information could be available to U.S. command posts (discussed below) almost immediately. Several minutes more observation could lead to at least a very rough indication of the intended targets, to the extent of predicting whether the Central United States (where U.S. silos are) only was under attack or whether coastal targets were included as well. This information might suggest whether the attack was directed only at U.S. silos or whether it was a massive attack on all U.S. targets, cities (many of which are on the coasts) included. It would not be possible on the basis of this early information to tell whether the Soviets had withheld attack on certain specific targets, an indication of their intentions.

It would not be possible to secure such satellites absolutely against attack on them, but such an attack could be made very difficult.

Though geosynchronous orbit would be most convenient for such satellites, it could perhaps be desirable to deploy them in other, higher orbits. Geosynchronous orbit is that unique orbit 22,300 miles from the Earth at which the orbital period of satellites is equal to the rotation period of the Earth. Thus satellites in geosynchronous orbit remain over the same point on the Earth's surface as both they and the Earth go round. A single satellite could therefore keep watch over the Soviet Union at all times. Because of its convenience, however, geosynchronous orbit is somewhat crowded, it would therefore be possible for the Soviets to station a "space mine" near to a U.S. warning satellite and answer in response to U.S. protests that the mine was in fact some other sort of satellite (e. g., communications) which it was convenient to position over the Soviet Union. The United States would then not be in a position to assert that the Soviets had no business there, because it would be quite plausible that they did have legitimate purposes for positioning a satellite in this unique, convenient orbit. If on the other hand the U.S. satellites were in an orbit chosen more or less randomly from amongst the infinite number of possible altitudes, we would be in a better position to assert that the only possible purpose for a nearby Soviet satellite must be to interfere with ours. The United States might then justify on these grounds measures against such interference. Nonsynchronous orbit means that more than one satellite would be required to keep continuous watch on the Soviet Union, however, since at any one time most of them would be over other parts of the Earth.

Satellites could also be threatened by direct attack from a missile launched from the Soviet Union. However, the U.S. satellites could be positioned high enough that it would take many hours (18 or so) for an attacking vehicle to reach them. What is more, since the interceptor missiles required to reach high orbits would be quite large, the Soviets would probably launch them only from the Soviet Union. Most of the satellites would be on the other side of the Earth when the first interceptor was launched, and launch of other interceptors

would have to be staggered so as to intercept the rest of the satellites as they "came a round." Direct-ascent anti satellite attacks on high orbits would therefore present a timing problem to the Soviets. The United States would most certainly be aware that the satellites were under attack hours before they were destroyed.

Measure can also be taken to insure the survival of satellites. For instance, they could be provided with sensors to allow them to determine when they were under attack. They could maneuver to avoid a homing interceptor and deploy decoys or chaff to confuse homing sensors. Satellites at such distances from the Earth might also be able to be hidden entirely by giving them small optical, infrared, and radar signatures. One might also hide dormant backup satellites amongst a swarm of decoys; the satellite would be turned on when the primary satellites encountered interference. Last, backup satellites could be deployed on missiles in silos in the United States and launched into low orbits to replace the primaries. These reconstituted satellites could also be attacked, but it would take time for the Soviets to acquire data on their orbits, even assuming the United States allowed them unhindered operation of the means to acquire this data. Some of these techniques for satellite security are more effective than others.

Last, the United States might not choose to show patience indefinitely with persistent Soviet attacks on our warning sensors, particularly if we had chosen to rely on LUA as the guarantor of our land-based missiles,

## Radars

Radars could be either land-based or deployed on oceangoing ships, Radars deployed near the United States would provide warning information rather later than satellites — perhaps 15 minutes or so after launch — but they would provide much more accurate prediction of the impact points of attacking RVS. This information would be sufficient to determine which silo wings and which metropolitan areas were under attack.

Powerful radars of this sort would be rather large and soft targets and therefore susceptible to SLBM or even paramilitary attack, jamming is also a potential threat. An endo-atmospheric ballistic missile defense could be provided around such radars. For instance, the Perimeter Acquisition Radar at Concrete, N Dak., happens to be in the area selected by the United States as the only site where an ABM system can be deployed within the ABM Treaty and Protocol. The purpose of such an ABM system would not be to protect the radar against any level of attack, but to force the Soviets to send so many warheads to destroy it that such an attack would constitute a major provocation

### Sensor Aircraft

Aircraft carrying radars (similar to AWACS aircraft used for tactical purposes) or infrared sensors could be used either as a backup for other sensors, taking off from a strip-alert status at U.S. bases, or as a primary system maintaining continuous airborne patrol. The aircraft could be on station within several hours of takeoff and could provide detailed attack assessment information (similar in character to the land-based radars) within about 15 minutes of impact.

Such aircraft would be a hedge against disruption of satellite or fixed land-based systems. If on continuous patrol, they would be very resistant to ballistic missile attack.

Since the aircraft would take some time to arrive on station if they were not maintained on continuous airborne patrol, there could be a gap between destruction of the primary U.S. systems and reconstitution by the aircraft. This gap could be filled by rocket-launched probes.

### Rocket-Launched Probes

These probes, carrying long-wave infrared sensors, would be similar to the probes proposed for the Overlay exoatmospheric ballistic missile defense system to acquire its targets. They would arrive on station in minutes and provide detailed attack assessment information similar to that provided by the aircraft un-

til they fell back to Earth about 20 minutes or so after launch. Housed in silos, they would be vulnerable only to nuclear attack. The probe silos could be located far from ICBM silos so that their launch could not be confused with ICBM launch by Soviet warning sensors.

### Nuclear Detonation Detectors

Since SLBM RVS could arrive on U.S. territory well in advance of the ICBMS aimed at the silos and before the time that a launch decision would have to be made, these detonations could provide further confirmation that the United States was under attack. Such detectors could be bolted on to large numbers of satellites deployed for other purposes. Alternatively, U.S.-based sensor stations employing seismic or electromagnetic pulse detectors could verify that the U.S. was under nuclear attack. It is very unlikely that natural phenomena could mimic the effects of nuclear detonations.

Though the detonation of nuclear weapons on the United States would not by itself necessarily identify the Soviet Union as the attacker, the other warning systems would either indicate the origin of the attack or be of such a nature that their disruption could be accomplished only by the Soviets.

### Covert Warning Sensors

It might be possible to deploy warning sensors the existence of which could reasonably be kept secret from the Soviets. Even if this did not actually turn out to be possible, it would be a factor the Soviets would have to consider before they satisfied themselves that the United States would be without advance notice of their attack.

### Warning Sensors for SLBMS

So far discussion has concentrated on warning of ICBM attack. All of the means described so far are applicable to the SLBM case as well. The satellites would give a launch count immediately and coastal SLBM radars impact point prediction within minutes of approach to the coasts. Planes and probes would be rel-

actively inefficient in the SLBM role since many of them would be required to cover all attack corridors.

### Command Posts

Fixed land-based command bunkers of a hardness sufficient to withstand attack even by inaccurate SLBMs would be difficult to construct. The United States now operates a network of fixed command posts including the National Military Command Center (NMCC) in the Pentagon, the Alternate National Military Command Center (ANMCC) at a rural site outside Washington, Strategic Air Command (SAC) Headquarters in Omaha, and North American Aerospace Defense Command (NORAD) Headquarters in Cheyenne Mountain, Colo. An improvement on fixed sites would be to deploy a fleet of wide-bodied aircraft with the necessary communications equipment to receive and process warning information, communicate with NCA, and launch U.S. silo-based missiles if given proper authorization. Some of these aircraft, called Airborne National Command Posts (ANCPs), could be on continuous airborne patrol and others on strip alert. The United States deploys a fleet of such aircraft at present. If there were advance indication of imminent Soviet attack, the President himself or other NCA could take to the air in these command posts.

Consideration might also be given to ground mobile command posts, disguised as vans traveling the Nation's highways.

Concerns could be raised about possible means to destroy or disrupt such command posts, but since they are considered for use with just about all MX basing modes, any such problems would not distinguish LUA basing. In fact such disruption would be very difficult.

### Communications Links

Studies of command, control, and communications (C<sup>3</sup>) systems to support strategic nuclear forces of any kind, LUA or otherwise, indicate that there is a wide variety of possibilities for wartime communications and just

as wide a range of means to disrupt and impede such communications. The nature of the disruption would depend on the amount of damage done to U.S. communications installations and the extent of disruption of the atmosphere due to nuclear explosions. An LUA C<sup>3</sup> system would have an advantage over systems supporting survivable basing because it would be needed at a time when the United States had suffered less damage. On the other hand, it would be at a disadvantage in that there might be little time to attempt to reconstruct disrupted links.

Many of the same considerations apply to the communications links which applied to the warning sensors. None can be protected absolutely against Soviet attack, but disruption can be made difficult, time consuming, and provocative.

Communications links are required from the warning sensors to the command posts, from the command posts to the missile fields, and between the command posts and responsible launch authorities. The first two are easier to specify than the last, since this last depends sensitively on where the launch authorities are assumed to be and upon whether they are under attack or not. A fuller discussion of the problems of providing communications systems to support strategic nuclear forces in general is contained in a separate chapter. The following discussion seeks to sketch some of the considerations relevant to LUA.

### Warning Sensors to Command Posts

It appears that satellite communications would be needed for this purpose, at least for the warning satellites, since they would not be connected to the command posts by line of sight. The same considerations regarding survivability apply here as for the warning satellites, but the situation is in some respects easier. To avoid jamming and ionospheric disruption due to high altitude nuclear detonations, these satellites could operate at millimeter wavelengths. They could be stationed in unusual, deep-space orbits so the Soviets could have no pretense for stationing space

mines near them, and direct-ascent interceptors would require a long time to reach them. Since the communications satellites would be cheaper than the warning satellites, there could be many of them. Other measures — deep-space storage, concealed dormant satellites, decoys, maneuverability, etc. — such as described for the warning satellites could also be tried here. Rocket-launched reconstitution satellites could be on-station in a short period. There are many U.S. communications satellites of all sorts in space, and arrangements could also be made to use them if the primary system failed.

Fixed ground stations for the downlinks would be vulnerable to attack, but such attack would at least be *required* to disrupt them. They could be proliferated throughout the United States and even defended with ballistic missile defense. An improvement on fixed ground stations would use mobile ground terminals, highway-going vans with concealed receiving dish and data processing equipment. Data could be transferred from ground stations—fixed or mobile—to the airborne command posts by radio (line-of-sight if necessary) and satellite uplink.

Ground stations would not be necessary at all if arrangements were made for the airborne command posts to receive data in semiprocessed form directly from the warning satellites via the communications satellites using millimeter wave or laser links.

The sensor aircraft would use satellite links to communicate with the command posts. The fixed radars could use radio (line-of-sight if necessary) or satellite to send their data to the command aircraft. The rocket-launched probe would be in line-of-sight with the command posts and could communicate directly.

### Command Posts to Missile Fields

If an order were given to launch MX missiles from their silos, the command posts could transmit the EAM to the launch control centers in the silo fields or directly to the silos by a

variety of means, including line-of-sight ultra high frequency (UHF) radio and satellite injection. These methods provide for high probability of correct receipt of the EAM within minutes, even in a disturbed environment.

### Between Command Posts and National Command Authorities

This is the most difficult part of the communications system to specify. The reason for this is not that technology does not provide solutions, but because these solutions could depend on where the NCA might be, which depends on who the NCAs are, which in turn depends on what procedures are adopted for NCA continuity.

Roughly speaking, there are three cases to consider. In the first, the President or other NCA is in Washington, and Washington has survived at least to the point in time where a launch decision is required. Communications in this case can be by satellite or airborne relay using a number of aircraft, maintained on strip alert in peacetime, which form a net over the United States for UHF line-of-sight communications.

In the second case, the President or other NCA is himself in a command airplane. Communications is by satellite or airborne relay.

In the third case, Washington is destroyed and the President did not manage to make it to a survivable location. In this case the important questions are, first: Who and where is the NCA and can it be arranged that they take command in time to launch under attack? and second: Does it matter if we could not LUA? since it might appear in this case that war was not going to remain limited and our other nuclear forces would be sufficient to achieve U.S. objectives. The first is a question of procedures and authority and the second of doctrine. They obviously cannot be answered by technology assessment. Some suggestion of alternative responses to these questions will be made in the section below entitled Procedures.

## Pindown

Pindown refers to the possibility that the Soviets could force our missiles to remain in their silos by threatening to explode nuclear weapons in their paths and destroy them in flight. In practice, however, pindown of silo-based MX would require a huge expenditure of Soviet weapons for an uncertain result and is therefore not an important threat to LUA.

In a pindown attack, nuclear weapons from SLEMs and, later in the attack but before ICBM arrival on U.S. silos, low-trajectory ICBMs could seek to create an environment lethal to U.S. missiles in flight. These warheads would be exploded at high altitudes— about 300,000 ft— in the flyout corridors above the missile fields. The relevant parameter here is the number of weapons of a given yield which must be exploded every *minute* in the flyout corridors to ensure that any missile passing through them is destroyed or disrupted. The damage is caused by X-rays from the nuclear explosions, and there are two possible kill mechanisms. In the first, X-rays are deposited on the exterior of the missile and vaporize the surface. When the surface layer is removed, the recoil momentum is transmitted through the missile as a compression wave which can damage the interior of the missile or blow the backside off. The other method by which the X-rays could disrupt the missile is by causing ionization in the electronic circuits of, for instance, the guidance computer.

The flyout corridors above the existing Minuteman wings are in fact rather large, and their precise dimensions can to some extent be made uncertain to the Soviets. In addition, the MX missile is planned to be much more resistant to X-rays than Minuteman. The Soviets would also not know with confidence just how hard U.S. missiles were.

On the other side, if the Soviets were genuinely determined to try a pindown attack, they could design warheads especially for this purpose. These warheads would not need heat shields since they would not reenter the atmosphere. Thus a warhead of a given yield

would be lighter, meaning more megatonnage on a given booster.

“The upshot of all this is that, if MX missiles were distributed throughout the Minuteman fields, the Soviets would have to explode hundreds of megatons per minute in the flyout corridors to guarantee pindown. If the Soviets assumed that no U.S. launch decision could possibly be made until at least 10 minutes into the attack, 15 to 20 minutes of pindown would be required. Timing constraints would demand that much of this megatonnage be launched from submarines remote from their home bases. Pindown would therefore compete with other time-urgent missions of the forward-deployed Soviet submarine force and with secure reserve missions of the remaining force. These time constraints, combined with the huge numbers of weapons needed, make pindown an unattractive, if not impossible, Soviet strategy against LUA for silo-based MX. (Reckoning strictly on the size of deployment area, the amount of megatonnage required to pin down MX in MPS basing would be about ten times less than for silo basing.)

## Procedures

For the U.S. threat to launch under attack to be credible, procedures would have to be devised to **guarantee** that the president or other NCA were able to communicate in timely *fashion* with the command posts in a position to receive attack assessment data from the sensors and execute the missile force. The issue here is not whether the U.S. instruments of command would eventually reconstitute themselves to wage and terminate a nuclear war, but whether there would be continuity of command in the first half hour of the war. Devising an acceptable set of procedures is a matter for decision at the highest levels of political authority. It is not the intention of this discussion to suggest or speculate what these procedures might actually be should the United States adopt reliance on LUA, still less what procedures support the present LUA capability, but merely to set out the logical possibilities.

These possibilities are quite distinct depending on the circumstances of the attack. In particular, it matters whether the possibility of attack was foreseen before the actual launch of Soviet missiles (i.e. whether “strategic” warning preceded “tactical” warning) or whether the attack was a “bolt from the blue” surprise. Realistic or not, much fear about reliance on LUA focuses on the second circumstance. Surprise attack is clearly most stressing as regards the physical capability of the United States to launch under attack.

It would also be vital whether the Soviet attack had the specific aim of disrupting the U.S. chain of command supporting LUA. As has been discussed above, every effort can be made to preclude the possibility that the Soviets could deny the LUA capability by means *short of* physical attack upon the NCA. It appears that such efforts could be quite successful indeed: sensors, command posts, and communications links could be provided, with cost and effort, which were very difficult to disrupt. Thus, as a practical matter, the Soviets could be faced with the choice *either* of permitting LUA *or* of attacking directly the U.S. political leadership. To make this choice the Soviets would have to ask themselves whether they preferred to be at war with a nation in possession of intact national leadership and usable ICBMS or with a nation in possession of neither. The U.S. perception of what the Soviets would intend in making such a choice could affect the procedures the United States selected for its LUA system. For instance, if it were agreed that the Soviets could not intend anything but total war if they were willing to “decapitate” the U.S. Government, then it might be concluded that U.S. bombers, cruise missiles, and SLBMS were sufficient weapons to wage such a war. U.S. doctrine might then state: LUA seeks to deter Soviet attacks *short of* decapitation; decapitation attacks are to be deterred by threat of retaliation upon Soviet value. On the other hand, if the United States judged such a doctrine to be inadequate, a determined effort would have to be made to devise procedures which would permit LUA in all circumstances. The United States might further judge it imprudent to state a doctrine

covering all possibilities, preferring to add uncertainty to the Soviet decision.

Questions of doctrine would thus have an obvious effect upon which procedures were adopted for LUA basing and are just as obviously not susceptible to technical analysis. In what follows, it is assumed that the United States would wish to assure the LUA capability in all circumstances, and various possibilities are explored to satisfy this wish. At the point where these procedures are judged to become unacceptable, one has the choice of abandoning LUA basing altogether or determining that the circumstances in question would no longer require a “survivable” (via LUA) U.S. ICBM force.

### The National Command Authority

NCA is the phrase used to describe the operational institution of the U.S. Government responsible for decisions to initiate the use of nuclear weapons. The individuals who occupy institutional roles comprising the NCA are called the National Command Authorities (also NCA). These individuals consist of the President and, upon his death or incapacitation, his successors as designated by the Constitution and the Presidential Succession Act; the Secretary of Defense and his successors; and the joint Chiefs of Staff and their successors, these designated by Defense Department regulations.

The process by which the NCA might order the use of nuclear weapons by U.S. Armed Forces has for obvious reasons not been discussed publicly. Hearings conducted by the House Foreign Affairs Committee in 1974 made clear that no military officer may initiate the use of nuclear weapons unless authorized by the President or his successor. In practice, it appears that many of the procedures for NCA operation are decided by each President on the basis of personal preference.

### Attack With Advance “Strategic” Warning

In a period of crisis, it might become apparent either from Soviet statements, from intelligence indications, or from estimation of



Soviet reaction to U.S. moves, that nuclear attack was imminent. Such advance warning is called "strategic" warning to distinguish it from warning indicating that an attack is actually in progress ("tactical" warning).

One reaction to strategic warning would be for the President or other NCA to take to the air in airborne command posts for the duration of the crisis. There could be concern that this action, if made known, could heighten tensions and provoke panic in the U.S. public. For this reason the President himself might wish to remain on the ground and have a lesser official assume airborne alert. Whether this could be accomplished covertly could be questioned since the command planes would be rather distinctive. Even disguising them to look like freight aircraft would be pointless if they took off from military airfields like Washington's Andrews Air Force Base. Disguising the movements of high U.S. officials from the press, particularly under the circumstances, might also prove difficult.

An alternative to providing a "survivable" NCA would be for the President to decide in advance the responses to be made to certain sets of attack assessment data and order that these responses be executed unless he were able to intervene to veto or change them. The responses would be transmitted to ABNCPS, the crews of which (presumably military officers) would be the executors. Whether such an arrangement would actually constitute delegation of command authority to others is not clear, since the precise instructions could be encrypted and thus totally unknown to the executors.

### Surprise Attack Without Decapitation

A "bolt from the blue" attack whose object was not to disrupt the U.S. chain of command could in principle be dealt with by arranging for the President and other NCA to be at all times in instantaneous, reliable communications with the command posts which monitor warning data and launch the ICBMS. As a practical matter, of course, account must be taken

of circumstances when the President is traveling abroad or shaking hands in a crowd. Though it would seem that adequate procedures could be worked out for such cases, they might be burdensome and obtrusive for the President and other NCA.

### Surprise Attack With Decapitation

This would be the most stressing circumstance for a system of LUA. There are several procedures that could be devised to meet this circumstance:

LUA fails. This "response," discussed previously, considers that this circumstance, implying Soviet willingness to destroy the political leadership of the United States, would be outside of the range of contingencies for which ICBM "survivability" is intended. U.S. doctrine could so state or imply.

2. Responses decided on in advance by the President would be executed by ABNCPS *unless* the President or other NCA intervened to veto or change them. This option is identical to the second option discussed for the case of advance or "strategic" warning except that in this case these procedures would be in force at all times, even when no particular crisis were occurring. The character of the response to be made to a given set of warning data could be encrypted and known only to the President. As a hedge against espionage or revelation of the President's choices, the instructions could be arranged to establish only the *probabilities* that certain responses would be made. These probabilities could be made to change on a day-to-day basis according to the world situation. The whole set of responses could be "wired into" the ICBM force or executed by the intervention of the crew of the ABNCP.
3. Launch authority could devolve on the crew of the survivable command posts. The NCA could override command post

decisions *if* they survived and were in communication. It has been suggested that the time during which such NCA intervention could take place might be

lengthened by preserving the option to disarm missiles in flight if the NCA chose to veto or change a launch decision made by others.

## OPERATIONAL POSSIBILITIES FOR LUA

This section illustrates the operational possibilities for a system of reliance on LUA in the form of attack “scenarios.” These scenarios are a *mat* technical verisimilitude, but no claim is implied that what happens in them is in any other sense plausible, much less acceptable.

The range of possible LUA scenarios is limitless, and each could be embellished. At each juncture, many different paths could be taken. The choices made here, when they have any particular rationale at all, are made to illustrate the workings of the technical hardware. It is not thought appropriate for a technology assessment to adopt any other approach.

All the scenarios described assume no advance or “strategic” warning and that the United States makes every effort to preserve its capability to launch under attack,

As a reminder of the elements of the LUA system described in the previous section, the following list is provided. It should be recalled that these are elements of a hypothetical/*future* system to support *reliance* on LUA, not elements of the system that presently supports the U.S. LUA *capability*.

- National Command Authorities (NCA)
- Fixed Ground Command Post
- Airborne National Command Posts (ABNCPS), continuously airborne or backup strip-alert at Central U.S. airbases
- Warning satellites
- Fixed ground radars
- Sensor aircraft, continuously airborne or backup strip-alert
- Rocket-launched sensor probes
- Coastal SLBM radars
- Nuclear detonation detectors
- Communications satellites, primary and reconstitutable

The scenarios are organized by timeline with, T = indicating the time in minutes

### Illustrative Soviet ICBM Attacks on U.S. Silos Only

These “scenarios” illustrate the LUA timelines for pure countersilo attacks in which no effort is made by the Soviets to deny the U.S. LUA capability. One might imagine any number of sequences of events leading up to these attacks. The only important assumption for these examples of LUA is that strategic warning has either not been received or has not caused the United States to assume an alert or “generated” posture. The first, small attack is termed a “demonstration” since, apart from destroying a subset of US, ICBMS, it would seem to have no clear purpose other than to demonstrate Soviet willingness to use nuclear weapons and to test U.S. willingness to respond. The Soviet attack in the second scenario is the standard “limited counterforce” attack whose purpose is to destroy the U.S. ICBM force completely,

#### Illustrative Small “Demonstration” Attack

T = 0: Soviets launch fifty SS-18 ICBMS.

Interim: U.S. fixed and airborne command posts receive satellite data indicating number and type of missiles launched and Soviet silo wings of origin. No evidence that SLBMS are included in the attack. Immediate measures taken to open communications links with President or other NCA. Backup ABNCPS, sensor aircraft, and perhaps other forces alerted,

T = 5: Further satellite data indicates Central United States as location of targets. Coastal targets known to be excluded, but targets in Central United States not further specified. Backup ABNCPS and sensor aircraft ordered to take off. Military commanders order launch of infrared probe.

T = 10: NCA in communication with command posts and alerted to situation, Probe on station and acquiring data.

T = 15: Infrared and radar planes, probe, and land-based radars all indicate that attack consists of about 500 RVS. Predicted impact points correlate with locations of three out of six U.S. ICBM wings, No evidence of any other targets.

T = 20: NCA orders no LUA since only half of ICBM force under attack, OR: NCA orders launch of 50 U.S. RVS targeted at Soviet SS-18 and SS-19 silos. Simultaneously U.S. embassies, including Moscow, informed of intent of U. S, response. *OR: Et cetera.*

Interim: U.S. ICBMS launch (if applicable).

T = 30: Soviet RVS impact U.S. silos.

### **Illustrative Full Attack on U.S. ICBMS**

T = 0: Soviets launch several hundred ICBMS.

Interim: As before.

T = 15: Aircraft, probe, and radars all indicate attack of over 2,000 RVS targeted at all ICBM wings. No evidence of other targets.

T = 20: NCA orders launch of the half of the ICBM force postured for LUA at Soviet silos and perhaps other military targets. *OR: NCA orders entire ICBM force launched. OR: Et cetera.*

T = 20-30: As before.

### **Illustrative Soviet ICBM/SLBM Attack on U.S. Silos and LUA Capability Excluding Washington**

T = 0: Soviets launch ICBMS at U.S. ICBMS. Simultaneously, SLBMS from submarines near U.S. coasts launch at fixed command posts, fixed communications nodes, fixed sensors, and airfields supporting airborne sensors and command posts. All of these targets are assumed to be located in Central United States or, if near coasts, not to be attacked. Coastal SLBM radars are not attacked since they collect most of their information before they can be destroyed.

Interim: Continuously airborne ABNCP receives satellite data indicating: number and types of ICBMs and silo fields of origin; number, type, and launch locations of SLBMs. No information about intended targets at this time; therefore not yet clear whether Washington and other coastal targets under attack. Immediate efforts taken to open communications links with NCA. Backup ABNCPS and sensor aircraft scrambled.

T = 5: Further satellite data indicates Soviet ICBMS and SLBMS targeted at Central United States, not coasts; actual Central U.S. targets not specified. Coastal radars, however, indicate SLBMS targeted at inland fixed ground command posts and communications nodes, radars, and airfields where backup ABNCPS and sensor aircraft are based. One SLBM RV appears to have ballistic trajectory which will carry it far from any U.S. military installation. Military commanders order launch of infrared rocket probe,

T = 7: SLBM RV with "odd" trajectory bursts at very high altitude over Eastern United States. No damage whatever to buildings or population from this very high-altitude burst, but electromagnetic pulse and ionospheric disturbances disrupt some long-range radio and line communications. Satellite communications linking NCA, fixed command posts, and ABNCPS is undisturbed.

Interim: SLBM RVS impact Central U.S. targets. Fixed command posts destroyed; command shifts exclusively to ABNCP. Large number of RVS targeted at fixed radars saturates ballistic missile defense; radar destroyed. Some, though not all, backup ABNCPS and sensor aircraft escape.

T = 15: Sensor aircraft and probe indicate that Soviet ICBMs are targeted at U.S. silo fields only. Nuclear detonation detectors confirm SLBM detonations, Data made **available to** NCA.

T = 15-20: NCA concludes on basis of information available that Soviet countersilo attack

in progress SLBM attack evidently attempted to deny U.S. LUA capability,

T = 20: NCA orders LUA.

Interim: U.S. ICBMs launch.

T = 30: Soviet ICBM RVS impact empty silos,

### Illustrative Soviet ICBM/SLBM Attack on U.S. Silos, Other Military Targets, LUA Capability, and Washington

This attack adds the crucial ingredient of direct attack on Washington. It would seem reasonable to assume that if the Soviets were willing to target the U.S. National Capital and political leadership, they would target also military targets unrelated to the U.S. ICBM force or LUA capability such as submarine and bomber bases. This assumption, made here, would not affect the U.S. capability to LUA but could make Soviet intentions clearer in the early minutes of the attack.

T = 0: Soviets launch ICBMS and SLBMS,

Interim: Satellites indicate ICBM and SLBM launches. Number and type of ICBMS launched consistent with countersilo attack. Number of SLBM launches indicates determined effort to destroy time-urgent U, S, military capability as well as LUA capability. Attack judged massive by command posts. Immediate measures taken to assure communications between NCA and ABNCP. Backup ABNCP and sensor aircraft, as well as strategic bombers, alerted.

T = 5: Further satellite and coastal SLBM radar data indicate Washington under attack. impact expected at T = 10. NCA notified urgently by command posts.

Soon after. SLBM impacts on Washington. ABNCP loses contact with NCA. No procedures to reconstitute NCA in time to LUA. LUA fails.

OR, as above, until:

T = 5: Peacetime procedures allow for full two-way communications between NCA and command posts at this time. Informed of situation, NCA authorizes LUA if Wash-

ington destroyed and makes choice among retaliatory options. Crews of command posts do not know character of response chosen by NCA. NCA stays on the line.

Interim: Nuclear detonations on Washington. NCA goes off the line.

T = 12: ABNCP receives confirmation of nuclear detonations on Washington and many other U.S. targets from nuclear detonation detectors.

T = 15: Probe and sensor aircraft continue to indicate countersilo ICBM attack. ABNCP executes LUA according to NCA'S wishes.

Interim: U.S. ICBMS launch.

T = 30: Soviet ICBM RVS impact empty silos.

### Attempt to Disrupt U.S. Technical Capability to LUA Precedes Soviet Attack

This kind of "scenario" imagines a prolonged "war of nerves" preceding actual Soviet nuclear attack in the course of which the Soviets attempt, by means contrived not to provoke U.S. preemption, to destroy critical *hardware* elements of the U.S. LUA capability. These hardware elements include warning sensors and communications links, but not the NCA. Scenarios like this are sometimes cited as reasons to distrust reliance on LUA.

No system of warning sensors and communications can be made absolutely resistant to disruption. Rather, the United States could make such disruption time consuming for the Soviets, thus removing any element of surprise, and require that the means to disruption be extensive, provocative, and even overtly hostile. As a practical matter, one can also make a *subset* of the system virtually immune to disruption. Whether this residuum could be considered sufficient to support a U.S. LUA decision is not clear, but it could impose on the Soviets the concern that even if they accomplished the disruption of the rest of the system, the United States might still be able to launch under attack. Above all, of course, the Soviets would have to consider that before

their attempts at disruption had succeeded, the United States might preemptively attack them or at least inflict comparable damage on their systems.

The satellites are the element which, while susceptible to disruption, would take the longest to destroy. Direct-ascent antisatellite interceptors would take some 18 hours to reach the high orbits where the satellites could be placed. The United States would thus have ample warning that disruption was in progress. As a practical matter, such high-altitude direct attack would also be quite difficult for the Soviets to execute and would be subject to various U.S. countermeasures, as discussed in the previous section. It would also seem that Soviet preparations for such an attack could scarcely be concealed; for one thing, the boosters required would be the size of SS-18s or larger.

Space mines are a means whereby the satellites could be destroyed instantly, once the Mines *were emplaced*. As discussed in the previous section, unusual orbits could be chosen for U.S. satellites. The United States could reasonably assert that Soviet placement of space vehicles in the same or nearby orbits could have no other purpose than to disrupt the U.S. LUA capability.

In either case — direct-ascent interception or space mines — there would be no question of “surprise” attack. The United States could in addition possess the capability to launch a set of replacement satellites (perhaps less sophisticated and presumably in lower orbits) before Soviet disruption of the primary system were complete. These replacements, too, could be attacked, but this attack would also take time.

Supposing the United States permitted disruption of its warning satellites, still the air-

borne sensors, land-based (and perhaps ship-based) radars, and the rocket-launched probe would remain. One can conceive of threats (sabotage, close-in jammers) to the ground-based radars, but barring this, they could be hardened to the point where their destruction required nuclear attack. The probes could also be in hardened silos. Associated BMD systems could increase the price of destruction by ballistic missile attack.

Supposing now that the satellites and the radars *and* probes were destroyed, the sensor aircraft would still provide warning and attack assessment. It is generally believed that aircraft operating in North American airspace in wartime would be difficult for the Soviets to attack. These aircraft could operate out of their home airfields and, presumably, civilian airfields for long periods. Thus in a period of prolonged conflict, in which other U.S. sensor assets were destroyed and the United States wished maintain an LUA capability, these aircraft might provide enduring warning and attack assessment. Though not providing warning of Soviet attack at launch, they would still provide notice of attack within 15 minutes of the time a launch decision was required. Under the circumstances, U.S. decision makers would presumably put themselves in a position to make rapid decisions.

“Thus, a Soviet attempt to deny the **U.S.** warning and attack assessment capability could be made exceedingly difficult and risky, if not impossible. A similar analysis could be performed for the communications links described previously. Thus, vulnerability of the *technical* elements of the LUA capability **need** not be an “Achilles’ heel” for reliance on LUA. Whether the *procedures* supporting decision-making can be made as robust is another matter, as has been discussed extensively.

## SUMMARY OF CRITICAL ISSUES FOR LUA

This section summarizes the critical issues that might enter into a decision to rely on LUA as the guarantor of ICBM “survivability.” As is apparent from this chapter, **some of these**

issues, and most certainly judgments regarding them, are in the end nontechnical. Though technical analysis can further define these issues, it cannot resolve them. Certain of these

issues apply in some measure to survivable basing as well as to LUA; what matters for purposes of comparison are the *differences* between the two types of basing. For instance, that certain circumstances of LUA are unpleasant is obvious, but it is not clear in all cases that they are improved by delaying response.

It must be borne in mind that the observations made here apply to a hypothetical future system of reliance on LUA, not the means which support the present LUA capability.

### Information Available to Decision makers

Decisionmakers would require information concerning the extent and intent of a Soviet attack and confidence that this information was accurate. Technical analysis can specify which data might be available at certain times in the course of an attack but cannot suggest what information might be considered adequate to support a decision to launch offensive missiles.

In general, the earlier in the attack a sensor acquired information, the less detailed it would be. Thus, at the time of launch, the number, type, and origins of boosters launched could be specified. Several minutes later, it could be possible to determine whether the entire United States was under attack or just a portion thereof. By midcourse (**15 minutes from launch and 15 minutes before impact**), the **impact points of RVS** could be predicted. The locations of detonations of submarine-launched RVS on the United States might also be known. By this time, only **5 to 10 minutes would remain** for decision making.

One might legitimately question whether, if the United States possessed a *survivable* ICBM force, *better* information that this would be available to support a retaliatory decision within a short time. That is, given the widespread confusion and disruption of communications following even a small attack, the information supplied by warning sensors in the first few minutes might in fact be the most complete available for a long time after the attack. Deployment of a survivable force might

actually lead the United States to deploy fewer and less robust sensors than it would deploy if relying on LUA. Thus, as a practical matter, the information upon which to gauge response could conceivably be less with survivable forces than with LUA.

Despite the redundancy and technical variety of the warning sensors, there could be reluctance on the part of decision makers to base launch decisions on information collected by such remote means.

### Decision Timelines

Depending on the circumstance, the amount of time available for deciding on a response to Soviet attack could range from an upper limit of 20 minutes to no time at all. Meeting this timeline would probably require at least some provisional advance planning by the President and other NCA.

### Possibilities for Diplomatic and Other Activities

The LUA timeline would leave no time for diplomatic activities between attack and response. At very least, such activity could serve to signal to the Soviets U.S. perceptions of their attack and the intent of any U.S. response. Communication with other governments, U.S. overseas installations, and U.S. military forces worldwide might also be accomplished at this time.

However, it is not clear to what extent the circumstances of nuclear war, especially as regards disruption of communications, would permit such activities within a short period of an initial attack anyway.

### Providing for Launch Authority

Timely command decisions by authorized NCA is clearly a requirement for reliance on LUA,

This requirement would be most difficult to satisfy if the Soviets intended deliberately to destroy or "decapitate" the NCA. In this circumstance, possible options might be: LUA

fails (not intended for this extreme case); provision is made for very early NCA decision; decisions decided on in advance by the NCA are executed by others if the NCA does not veto or change them; launch authority is delegated to others than the NCA.

Which of these options, if any, would be acceptable is a matter not of technology but of decision at the highest levels of political authority.

Even in the less extreme case in which no attack on the NCA is intended, provision must be made for the NCA to be available at all times for rapid decision. Such procedures might be onerous for the President and other NCA,

### Fear That U.S. LUA Capability Could Somehow Be Sidestepped

The analysis presented here indicates that, from a technical point of view, sensors and communications could, with money and effort, be provided to make at least the technical elements of the LUA capability exceedingly difficult, if not impossible, for the Soviets to disrupt. Procedures to support decisionmaking are another matter. Even if both hardware and procedures were devised which were very robust indeed, it might not be possible to eradicate completely a lingering fear that the Soviets might find some way to "sidestep" the system. These fears could become aggravated at a time of crisis.

### Risk of Error

There are two risks of error in a basing system of reliance on LUA: the risk that launch

would take place when there was no attack, and the risk that launch would fail to take place when there was an attack.

Insofar as technology is concerned in the assessment of these risks, one can in principle make arbitrarily small the probability that electronic systems by themselves make either kind of error, though beyond a point efforts to decrease the chance of one error could increase the chance of the other.

But it would seem that the principal source of error might not be electronic or mechanical malfunction by itself. The odds that a sensor indicates something out of the ordinary might be quite high, but the chances that it indicates something resembling a plausible Soviet attack would be much smaller. The probability that *several* sensors based upon different physical principles indicated the *same* plausible attack would be much smaller still. That is, electronic systems tend to make random, rather than highly structured, errors. On the other hand, electronic systems have a very limited ability to correct errors once made. Human beings, by contrast, have a high capacity to correct errors, but also a high capacity to commit highly structured errors. The risk of error for an LUA system would seem highest when the human being's ability to make highly structured errors combines with the machine's limited ability to correct them. Mistakenly initiating a "simulated" attack by, e.g., loading the wrong tape into a computer, would be an error of this type. It is obviously not possible to set and enforce a bound on the probability that such an error could occur in an LUA system.

## Chapter 5

# SMALL SUBMARINE BASING OF MX

## Chapter 5.—SMALL SUBMARINE BASING OF MX

	<i>Page</i>		<i>Page</i>
Submarine Basing of Strategic Missiles ..	.167	Increased Radar Search Using Satellites.	186
Nontechnical Considerations .....	167	Countermeasures to Radar Satellites ..	.189
Technical Choices Leading to		War of Attrition .....	.189
Small Submarines ..	.169	Van Dorn Effect .....	...190
Description and Operation of the Small		Theory of Trailing. ....	191
Submarine System. ....	.170	Establishment of Trail at Port Egress. .	.193
Introductory Remarks. ....	170	Establishment of Trail Using Large Area	
Overview .....	171	Open Ocean Search .....	.196
Communications System and		Diesel-Electric Propulsion Technology. .	.197
Operational Procedures .....	173	Nuclear Electric Propulsion .....	.198
Submarine Navigation and Mapping		Concluding Remarks on the	
Needed for High Missile Accuracy ..	.174	Vulnerability of Submarines .....	.199
Missile Guidance Technologies .....	.175	Factors Affecting the Accuracy of Land-	
Vulnerability. ....	.176	and Sea-Based Missiles .....	199
Tactical and Strategic Applications of		Accuracy of Small Submarine Based MX ..	202
Antisubmarine Technologies .....	.. 177	Accuracy of Star-Tracker-Aided Inertially	
Theory of Open Ocean Barrage .....	.178	Guided MX .....	.205
Open Ocean Barrage With No		Degradation in Accuracy After a	
Information About Submarine		Submarine Navigation Fix. ....	..206
Locations .....	....179	Inertial Guidance Aided by Radio Update	.207
Open Ocean Barrage After Detection		Time on Target Control. ....	.208
of Snorkeling Submarines .....	180	Responsiveness of the Submarine Force. .	.209
Searches With Technologies That		Endurance of Force. ....	.210
Observe Nonsnorkeling Submarines. .	.182		
Increased Range Acoustic Technologies. .	184		



	Page
Cost and Schedule . . . . .	210
System Size. . . . .	212
Final Sizing Consideration . . . . .	213
Location and Description of Bases. . . . .	213

**TABLES**

Table No.	Page
21. Submarine Observables . . . . .	177
22. Acoustic Sensors for Submarine Detection . . . . .	177
23 Nonacoustic Sensors for Submarine Detection . . . . .	177
24 Operational Factors Affecting Radar Search of Submarine Deployment Areas. . . . .	182
25 Miss Sensitivities to Initial Errors for ICBM Trajectories. . . . .	201
26 Comparison of Hard Target Kill Capabilities of Sea-Based MX With Design Requirements of the Land- Based MX . . . . .	203
27 Small Submarine 10-Year Lifecycle cost. . . . .	211
28 Number of Submarines Required To Keep 100 MX Missiles Continuously on Station v. Submarine In-Port Time ..	213
29 Estimated Characteristics of the Small Submarine Refit Site and the Trident Refit Site. . . . .	214

**FIGURES**

Figure No.	Page
67, Nuclear and Nonnuclear Powered Submarines of Different Size . . . . .	171
68 Encapsulated MX Missile . . . . .	172
69 MX-Carrying Diesel-Electric Small Submarine. . . . .	173
70 Sequence of Events During the Launch of an Encapsulated MX Missile.	173
71 Number of Weapons Required to	

Figure No.	Page
Destroy Submarines That Have Been Sighted Prior to a Preemptive Attack ..	179
72. Potential Deployment Area Given 1,000- and 1,500-nmi Operating Ranges	180
73. Large Area Search With Technology That Can Only Detect Snorkeling Submarines. . . . .	181
74. Sources of Reverberation That Limit the Capability of High-Powered Active Sonars. . . . .	183
75. Potential Whale Sonar Targets . . . . .	185
76. Fishing Vessel Monitoring, ., . . . . .	187
77. Ground Track of Radar Search Satellite	188
78 Van Dorn Effect . . . . .	191
79 Active Acoustic Search for a Submarine That Has Dispensed Decoys Which Simulate a Reflected Sonar Signal From a Submarine Hull. ..	194
80 Passive Acoustic Search for Submarine That Has Dispensed Decoys Which Simulate the Sound of a Submarine . . . . .	195
81 German Type 2000 Submarine . . . . .	197
82 Factors Affecting the Accuracy of a Ballistic Missile. . . . .	200
83. Down Range and Cross Range Errors of a Ballistic Reentry Vehicle at a Target . . . . .	202
84. Accuracy of Inertially Guided Sea- Based Missile at Different Ranges From Targets. . . . .	202
85< Accuracy of Star-Tracker-Enhanced Sea-Based Missile as a Function of Range From Target . . . . .	206
86, Ocean Areas That Provide Adequate Line-of-Sight View of Ground Beacons on Continental U. S., Aleutian Islands, Alaska, and Hawaii . . . . .	208
87 Ocean Areas That Provide Adequate Line-of-Sight View of Ground Beacons on Continental U. S., Aleutian Islands, Alaska, Hawaii, and Selected South Sea Islands. . . . .	209
88 Small Submarine Program Schedule. ..	211

# SMALL SUBMARINE BASING OF MX

---

## SUBMARINE BASING OF STRATEGIC MISSILES

Strategic missiles are based on submarines because submarines can be hidden in vast expanses of ocean, thereby gaining a high degree of survivability. Currently, the United States takes advantage of the survivability of submarines to deploy the Polaris, *Poseidon*, and Trident I missiles. Unlike attack submarines, whose primary mission is to protect convoys or attack enemy shipping, these ballistic missile carrying submarines seek to avoid surface ships and remain undetected, available for strikes against enemy targets on command. The object of basing MX on submarines would be to take advantage of the same survivability that has been demonstrated by experience gained with the *Polaris* and *Poseidon* systems. One major question addressed in this chapter is whether this survivability can be expected to continue into the 1990's

MX has been conceived as a land-based intercontinental ballistic missile (ICBM). The land-based ICBM has historically had greater accuracy, flexibility of targeting and rapidity of response than that of sea-based missiles. As a land-based ICBM, the MX missile is expected

to set still a new standard in each of these attributes relative to previously deployed land-based missiles. The second technical question that is to be addressed in this chapter is the extent to which this new standard of attributes could be preserved if the MX were instead based on submarines.

Deploying the MX at sea rather than on land would also raise questions about how important it is to mix and balance the different attributes of nuclear forces to best deter war. The different points of view are summarized here, but these issues cannot be resolved by technical analysis.

This chapter begins by noting some of the principle rationales and drawbacks of submarine basing of MX. Some of these issues, while clearly relevant, are just as clearly not technical issues per se. The following sections attempt to more closely define and analyze technical and operational issues that bear on the problem of submarine deployment of a large, flexible, counterforce ICBM like MX. The conclusions of these technical analyses are summarized in the last section.

## NONTECHNICAL CONSIDERATIONS

Much of the interest that has been shown in submarine basing of MX is motivated by the perception that the survivability of a future submarine force is likely to be insensitive to the nature and size of the Soviet ICBM force. As long as the Soviets are not able to develop an ability to localize and track submarines, the only conceivable way they could preemptively attack the submarine force with ICBMS would be to randomly barrage suspected submarine operating areas. If the Soviet ICBM force were to grow in its ability to deliver large amounts of megatonnage, submarine operating areas could merely be expanded in size to counter such a threat. In addition, the Soviets could

gain no additional ability to threaten the survivability of submarines through improvements of accuracy technology or through fractionating the warheads on existing or new ICBMS. Thus, provided that submarines maintain their ability to hide in vast expanses of ocean, there would be little or no way to threaten their survivability with either a substantial expansion, or with technical improvements, of Soviet ICBM forces. A decision to deploy the MX missile at sea in submarines would therefore negate the effectiveness of the Soviet ICBM force as a means of threatening the MX missile. This decision could diminish the political leverage that the

Soviets have bought with their modernized ICBM force by removing their ability to threaten a major U.S. strategic weapon system.

A perspective that argues against the basing of MX on submarines holds that moving missiles off the land will result in fewer disincentives to an adversary who is contemplating the use of, or the threat of using, nuclear weapons as a means of extracting political concessions from the United States. This perspective views the basing of strategic missiles on land as insurance against political blackmail. An adversary who attempts to gain political advantage by threatening U.S. strategic systems with nuclear destruction would, in effect, be forced to threaten targets on American soil. Land-basing would make the price of attempts to gain political leverage in this manner very high, thus decreasing the likelihood of such blackmail.

Some who argue this way also believe that the United States would lack the resolve to respond to Soviet threats unless it was clear that the continental United States was threatened with nuclear attack. They fear that such lack of resolve could make nuclear war easier for an adversary to contemplate, thereby making it more likely.

Others disagree with these perspectives and argue that there is a beneficial effect of removing potential targets from the continental United States. Since there would be no clear gain in an unsuccessful attack against a survivable sea-based system, there would be no incentive to attack strategic systems. They argue that a land-based system that presents a serious threat to Soviet military systems could invite attack if a crisis deteriorated to the point where Soviet decisionmakers believed war was unavoidable. In such a circumstance, Soviet decisionmakers might attempt to limit damage to their own systems by striking first. If a submarine-based system were untargetable, a rational Soviet decisionmaker would be denied such a choice. Thus, submarine basing would have the stabilizing effect of forcing a wait-and-see attitude on decision makers during periods of international crisis.

A potentially serious drawback of basing MX missiles on submarines is that the system could share a common mode of failure with Trident and Poseidon if an unforeseen antisubmarine warfare capability emerged in the next 20 years. Since the United States, with its substantial commitment to undersea warfare, has been unable to identify or project any threat to ballistic missile submarines, the significance of such a potential drawback is difficult to evaluate.

Another potential drawback is that a submarine-based system would require highly skilled and trained personnel that are not currently available in the Navy. In order to meet additional manpower needs, training centers would have to be established and recruiting efforts would have to be expanded. If the civilian economy was healthy, competition for trainable people could make it difficult to attract them into the Navy. It could also be difficult to retain personnel once they have developed skills because of the attraction of lucrative civilian jobs.

Submarine construction presents somewhat different problems from that of surface ship construction. Past experience indicates that if shipyards do not demonstrate a good deal of competence constructing surface ships, they will have very great difficulties constructing submarines. Since the volume available for equipment and crew in a submarine is very small relative to that available on surface ships, construction must be carefully planned so that components can be put into cramped locations in the proper sequence. Quality control is also important since equipment and components may be subjected to extreme conditions during the course of submarine operations.

Constructing a new fleet of MX-carrying submarines would be a major undertaking. Three shipyards not currently engaged in submarine construction would probably be needed to construct submarines if the full fleet is to be deployed by 1992 or 1994. Each shipyard would have to be provided with a small team of people experienced in submarine construc-

tion to help it make an orderly transition to submarine construction. Lack of experience in submarine construction could result in program delays if the shipyards had not been carefully chosen for their efficiency and competence or if they did not have adequate guidance on submarine construction techniques

Delays could occur in other submarine construction programs as well, if the base of special materials required for submarine construction were not expanded to meet increased demands. It is also possible that if problems developed within the MX submarine program, talent, effort, and funding might also have to be diverted from those programs.

Other problems could arise with other elements of the project due to the timing of the missile development program. If missile development were delayed a year by design changes required for sea basing, it would be ready for deployment in 1987. The design, development, and construction of a new class

of submarines could in theory be expedited to produce lead ships by late 1987, but this appears unlikely. If the program proceeded at a rate more characteristic of recent strategic weapons programs, the lead ships would not be deployed until 1990. The missile could therefore be ready for deployment several years before there are means to deploy the missile. It would be necessary to keep missile scientists, engineers, and managers available for the testing and monitoring phase of the missile deployment. These individuals might have to be retained at great cost until the deployment is far enough along to assure that unforeseen problems had not emerged.

These perspectives, among others, involve judgments of a nontechnical nature and will not be addressed further in this chapter. Instead the focus will be on assessing the technical strengths and weaknesses of a sea-based MX system that was optimized to perform the missions usually ascribed to ICBMS.

## TECHNICAL CHOICES LEADING TO SMALL SUBMARINES

If an MX-carrying submarine force is to be specifically optimized to capture as many attributes of the land-based ICBM as possible, there are two attributes of the land-based ICBM that suggest small submarines carrying a few missiles are preferable to large submarines carrying many missiles. These attributes of the land-based missile are

1. flexibility of targeting that does not compromise survivability of unused missiles in the force, and
2. diversity in failure modes with the other legs of the Triad

Flexibility refers to a weapons system's ability to select and carry out preplanned attack options, or attack options that are subsets of preplanned attack options. It also includes the ability to carry out ad hoc attacks against targets that may be on the National Target Data Inventory List or targets that are specified only in terms of geographical location

Since a large ballistic missile submarine carries military assets capable of delivering enormous destruction against an adversary's targets, it is itself a target of considerable military importance. If the submarine's position were to become known in wartime, there would be a substantial incentive to attempt to destroy it.

If a flexible targeting strategy were adopted for a submarine force, submarines might be ordered to fire a limited number of missiles at enemy targets. The firing of these missiles could potentially reveal the position of the submarine to enemy surface ships at great distances, to space-based sensors, radar systems, and possibly even sonar systems. The expected postlaunch survivability of a missile-carrying submarine is therefore quite different from that of its expected prelaunch survivability. The flexible use of this force could therefore result in attrition that would compromise its ability to continue the war or force termination of the war.

If flexibility of targetting is specifically desired in a submarine force, it would be necessary to make the survivability of remaining missiles as independent of previously launched missiles as possible. This **could be done if the submarine force was made** up of a large number of submarines each carrying a small number of missiles. If this were the case, then the wartime loss of submarines that placed themselves at risk by launching only a few of their missiles would not result in the loss of a large number of remaining unused missiles. The force would therefore be able to carry out limited nuclear attacks without compromising its ability to carry out subsequent massive strike missions.

Another reason that submarine-based strategic weapons have been less flexible than land-based ICBMS in the past is that communications with submarines have historically not been as good as those achievable with land-based systems. As will be discussed later in this chapter, flexibility in targetting could be achieved with the current submarine force if a conscious decision were made to acquire certain kinds of communications capabilities and to adopt certain operational procedures.

Diversity in failure modes with other legs of the Triad is a more difficult attribute to

discuss, since it involves making judgments about threats that have not yet been identified. If the MX missile were deployed on small submarines, it seems more probable that it would share a common failure mode with other submarine-based systems than would a land-based system. The likelihood of such a breakthrough must be considered remote in the absence of any scientific evidence to support such a possibility. However, if an unforeseen antisubmarine capability developed in the future, it is possible there could be quantitative and/or qualitative differences between sea-based *Trident/Poseidon* submarine forces and submarine-based MX that could make the threat less effective against such diverse types of submarines. Small, slow-moving submarines would in fact have certain signatures that are different from those of larger, faster moving submarines. In addition, a fleet of many submarines poses both a qualitatively and quantitatively different set of operational problems to an antisubmarine force than does a fleet of a few submarines. With this in mind, it could be argued that a fleet of MX-carrying submarines would increase the diversity of strategic nuclear forces, making it less likely that a **single technology** could threaten all three legs of the Triad.

## DESCRIPTION AND OPERATION OF THE SMALL SUBMARINE SYSTEM

### Introductory Remarks

If the MX were to be deployed on a fleet of submarines, there would **be many engineering and operational tradeoffs that would have to be made if the fleet was to be an effective weapon system. In order to establish conservative bounds for what is likely to be achievable**, OTA has postulated a system of submarines, operational procedures, and communications that is specifically optimized to attain ICBM-like flexibility and responsiveness while still basing MX on submarines. The system concept to be described and evaluated is based on

off-the-shelf technologies, and Navy operational experience and practices wherever possible. However, it should be expected that if a national decision were made to deploy MX on submarines, many technical features of a new system of MX-carrying submarines would likely be different from those postulated for OTA'S analysis of small submarine basing. A new class of submarines would have to be designed and built. New and different procedures would also be evaluated and developed for the submarine operations. Such a vast enterprise as the design, **construction, and** deployment of a new and modern strategic

weapon system could result in a system with features different from the system that will be discussed here

### Overview

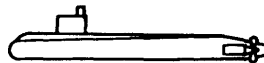
The submarine system to be described uses a combination of communications, navigation, and guidance technologies aimed at maximizing flexibility of targeting, rapidity of response, and missile accuracy. Submarine operational procedures are set up to allow submarines to carry out launch orders issued by the National Command Authorities (NCA) rapidly. There would always be enough subma-

rines to carry 100 alert MX missiles for delivery of highly accurate warheads against Soviet targets. It is believed that these submarines, while at sea, would be untargetable and impervious to Soviet preemptive actions (this issue is discussed fully in the next section) This submarine force is therefore optimized to carry out missions similar to those commonly ascribed to ICBM forces.

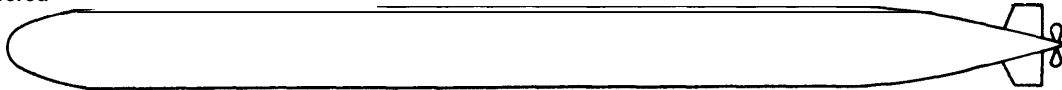
The basing system would consist of a force of 51 moderate-sized (see fig. 67) diesel-electric submarines each of which is armed with four MX missiles. The submarines could also be powered with small, low-enrichment

**Figure 67.—Nuclear and Nonnuclear Powered Submarines of Different Size**

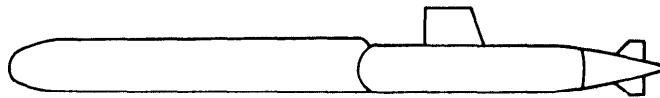
**Nuclear powered  
NR-1  
136' x 13'**



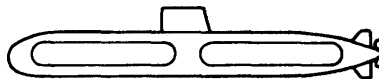
**Nuclear powered  
Trident  
42' x 560'**



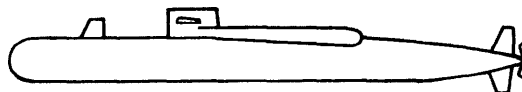
**OTA diesel-electric  
25' x 342'**



**German Type 2000  
small diesel-electric  
25' x 200'**



**Nuclear-turboelectric  
SSN-597 (Tullibee)**



nuclear reactors. During normal operations, 28 submarines would be continuously at sea. In periods of crisis or international tension, submarines in refit (but not those in extended refit or in overhaul) could be surged from port to raise the at-sea numbers to 38 to 40. This deployment would provide an additional 400 warheads on station.

The MX missiles would be carried in steel capsules approximately 80 ft long and 10 ft in diameter (see fig. 68). The capsules would be carried outside the pressure hull on the top side of the submarine's hull (see fig. 69).

On a launch command (see fig. 70), hydraulic actuators would open doors on the submarine's fairings and straps within the fairings would release the capsule. Soft ballast would then be blown from the front end of the capsule causing it to rise and rotate toward the vertical. Upon sensing the ocean surface, the top and bottom caps on the capsule would be cut free, the missiles motors would ignite, and

the thrust of the first stage motor would propel the missile from the capsule.

After missile flyout, a flotation collar and/or drag surface would deploy from the empty capsule to slow its descent into the ocean. This would lower the risk of a collision between the expended capsule and the submarine.

The submarines would deploy from dedicated bases in Alaska and on the east and west coasts of the continental United States. Each base would, on the average, have 5 to 6 submarines in port at all times. The submarines would be at sea for 60 days and in port for refit and logistic support for 25 days.

The submarines would typically operate as far as 1,000 nautical miles (nmi) from port. They would be designed to have sufficient speed and endurance to operate at still greater distances from port (1,500 nmi or more) if such operations were deemed desirable. Each submarine would have an advanced submarine

Figure 68.—Encapsulated MX Missile

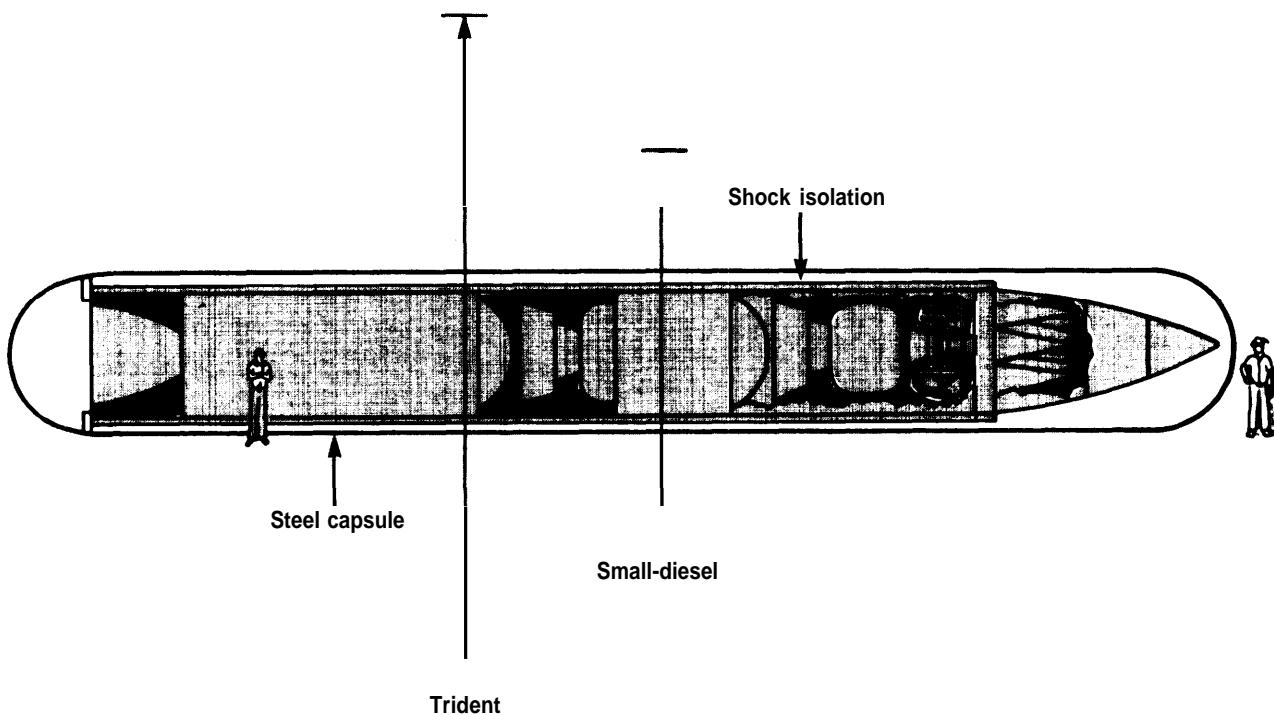
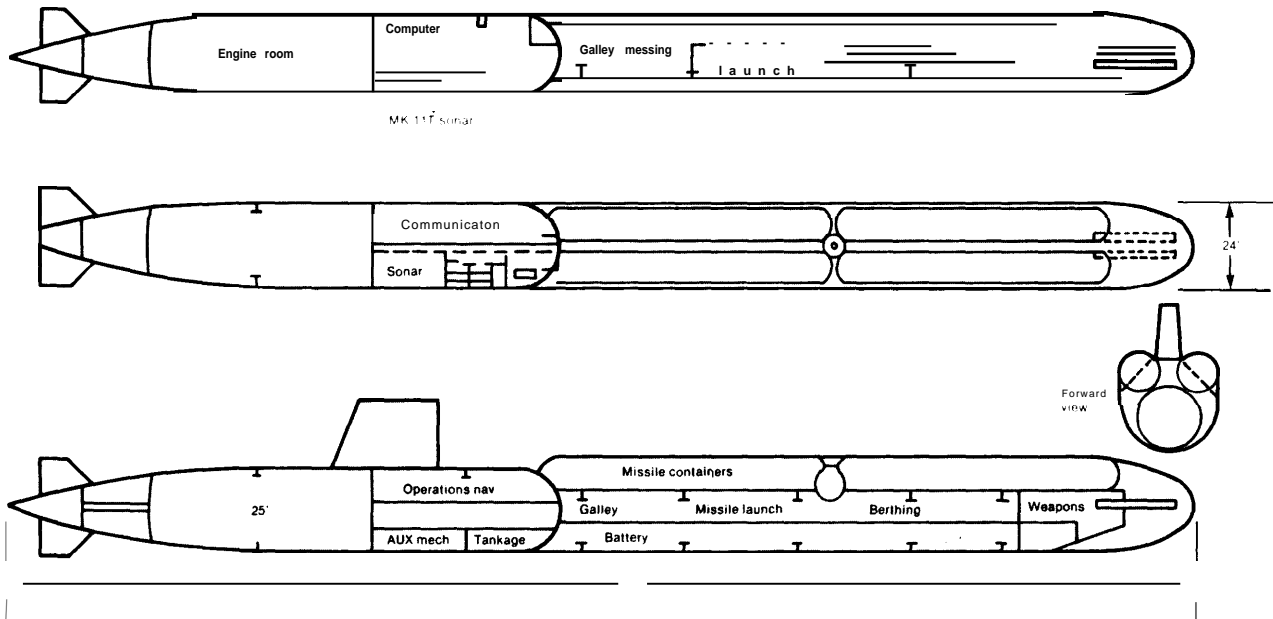


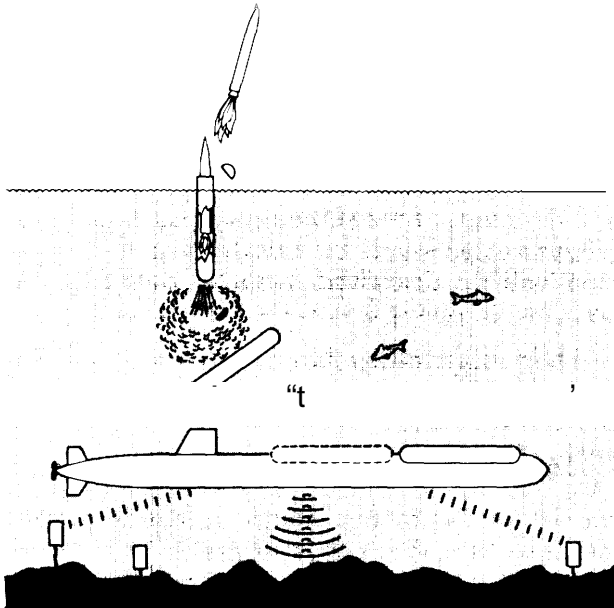
Figure 69.— MX"Carrying Diesel. Electric Small Submarine(3,300 tons submerged displacement)



\*Submarine design developed by considering the characteristics of the most recent U.S. built diesel submarines, the SS580, the SSG557 GROWLER Class REGULUS missile submarine, current technology represented in the Federal Republic of Germany submarine designs (H DW Type 209 and Type-2000 designs), and other advances demonstrated in Swedish and Netherlands designs. Proven technologies incorporated into design are maximum quieting achievable by sound isolation, air coupling of electric drive motor to screw shaft, faster recharging at lower snorkel noise levels, increased battery capacity, microprocessor monitoring and management of power systems, and smaller crew size.

SOURCE Office of Technology Assessment

Figure 70.—Sequence of Events During the Launch of an Encapsulated MX Missile



SOURCE Office of Technology Assessment

inertial navigation system (E SCM/SINS), a velocity measuring sonar (VMS), an acoustic system for interrogating prepositioned transponders, and equipment for taking fixes on the Global Positioning System (GPS) and LORANC.

Missile accuracy would be maintained mainly with onboard submarine navigational equipment. This equipment would occasionally be updated with the GPS or a covert system of acoustic transponder fields. If the GPS were destroyed by enemy action, the occasional navigational updates would be done with the acoustic transponder fields.

### Communications System and Operational Procedures

The communications system and operating procedures would be configured so that the submarines in peacetime would constantly be receiving communications from NCA through



trailing wire antennas and/or buoys that would constantly receive shore to submarine very low frequency (VLF) communications. In addition, the submarines could also be in two-way communications with NCA using a covert, rapid and reliable high-orbit satellite transponder link. This link would allow for the submarines to report back to NCA and make possible high data rate reception of information for rapid retargeting of the force.

Since shore-based **VLF stations would probably be destroyed** if there was enemy preemptive action, communications with the submarines would then be maintained via survivable airborne VLF relays, that could immediately replace shore-based VLF stations. These airborne relays would maintain radio silence and would be continuously airborne unless they were needed to replace shore-based VLF transmissions. Emergency Action Messages (EAMs) could be routed from NCA, through either the shore-based VLF stations, or the airborne VLF relays, to the submarines. (Today these airborne relays are known as TACAMO aircraft. TACAMO is an acronym for Take Charge And Move Out).

If there was a need for high data rate retargeting, or for two-way communications, designated submarines would be ordered via the VLF radio link to prepare for high data rate or two-way communications. In order to do this, the submarines would erect a mast above the ocean surface to permit communication through the high-orbit satellites mentioned earlier.

If there was a need for the submarine to report back to NCA, the submarine could beam a message through the satellite using a 5-inch dish antenna which would be mounted on a mast.

The probability of an adversary detecting or intercepting such transmissions would be very low for the following reasons. The radio **frequencies used** by the satellites would be in the extremely high frequency (EHF) radio band and would have a wavelength of order several millimeters. Because the wavelengths are so small, EHF signals would be collimated into an

extremely tight beam by the 5-inch dish antenna. Only receivers in the path of the beam could receive the transmissions from the submarine. Since the dish antenna would also be highly directional for receiving satellite signals, it would be effectively impossible to jam incoming signals from the satellite.

The satellites could be survivable against satellite attacks. The high-orbit satellites could be put in five times geosynchronous orbits (almost halfway to the Moon) and would be very difficult to attack, even using large space boosters.

Earth-launched interceptors would take 16 to 18 hours to reach the satellites. During this period, the satellites could be maneuvered while they are out of sight of Soviet ground-tracking stations, forcing the space boosters to make course changes beyond their propulsive endurance. If there was an extended period of conflict and the United States did not want to keep repositioning these satellites, the ground-tracking stations could be destroyed and the satellites could be repositioned for a final time.

### Submarine Navigation and Mapping Needed for High Missile Accuracy

In order to have high missile accuracy, the missile guidance system must have accurate information on the missile's initial velocity, position, and orientation immediately prior to launch. This information can be obtained from navigation systems on the submarine and from gravity maps of the submarine operating areas. These systems will be briefly described here and will be discussed again in detail in the section on missile accuracy.

The submarines would maintain accurate information on their position using an advanced submarine inertial navigation system ESGM/SINS. They could also measure their velocity very accurately using a VMS. This information would be fed to the missile guidance system prior to launch so that errors in missile accuracy due to velocity and position uncertainties would be minimal.

ESCM/SINS could be reset by making navigational fixes on the GPS. If the satellites were destroyed by enemy action, the navigation system could instead be updated using any of 150 covert acoustic transponder fields.

The acoustic transponder fields would be layed by submarines while on normal patrols. Typically, such operations would take several hours. After laying a transponder field, the submarine would determine transponder positions using the ESGM/SINS or the GPS. The transponder field could be turned on using an encrypted acoustic signal that could be sent from the submarine or by a small, powered, underwater drone deployed by the submarine. Small boats could later use an encrypted acoustic signal to command the transponders to release their anchors and float to the surface for retrieval. In this way, the transponder fields could be constantly shifted if the need arose.

Orientalional information for the missile guidance system would be obtained with the aid of gravity maps of submarine operating areas. These maps would be generated using satellites, surface ships, and possibly submarines to measure gravity anomalies near the surface of the ocean and in space.

### Missile Guidance Technologies

There are three sets of missile guidance technologies that could be used to maintain high accuracy from sea. These are:

1. pure inertial guidance,
2. star-tracker-aided inertial guidance, and
3. radio-aided inertial guidance.

The strengths and weaknesses of these systems will be described in more detail in the section on missile accuracy.

Pure inertial guidance would essentially be similar to that of the land-based missile, with some of the methods of performing missile guidance calculations modified for sea basing.

Star-tracker-aided inertial guidance would be similar to that of the land-based system but with the aid of a star tracker to help correct for position, velocity and orientational guidance

errors that accumulate during missile flight. These corrections are done by sighting on a star and comparing the star's measured position to that of its expected position. The Trident I missile uses a star tracker and experience with this missile has demonstrated that this technology is very reliable and effective as a means of obtaining high accuracy with sea-based missiles.

Radio-aided inertial guidance depends on radio beacons to correct for position, velocity, and orientational guidance errors that occur in missile flight. These corrections are done by sighting on a system of radio beacons.

The system of radio beacons used by the missile could be either on satellites (the GPS) or on the surface of the Earth (such a system has been called a Ground Beacon System (CBS) or an Inverted Global Positioning System (**IGPS**)).

If a submarine-based system used radio-aided inertial guidance as a means of maintaining high accuracy, a GPS guidance fix could be taken by missiles launched anywhere within the deployment area. In the event of outage of the GPS, which could occur if the satellites were attacked, the secondary land-based IGPS could be used to maintain the missiles' accuracy. However, if the ground radio beacons are used, the missiles might have to be launched within 400 to 500 miles of the ground beacons in order to get good enough line of sight contact to maintain missile accuracy.

The system of ground radio beacons could be deployed along the coast of the continental United States and Alaska. There would be a large number of such beacons and a larger number of decoys to make it costly for the Soviets to attack the beacons.

If the GPS were destroyed, and a launch order was issued, some submarines might not be close enough to the continental United States to use the radio ground beacons. If time permitted, NCA could direct the remaining submarines to redeploy to areas within the coverage of the ground beacons or direct them to any of 150 presurveyed acoustic trans-

ponder sites in the open ocean. The submarines could obtain extremely accurate measurements of both position and velocity at these presurveyed sites. Missile accuracies achieved from these transponder fields **could** be slightly degraded relative to that achievable with the aid of the radio beacons assuming that the missile was only inertially guided (i. e.,

the missile does not have a star tracker). If there was not enough time to redeploy to acoustic transponder fields, missiles could be launched with position and velocity information from the ESGM/SI NS and VMS submarine systems. Under these conditions, missile accuracy would be degraded still further.

## VULNERABILITY

The vulnerability of the force of submarines to Soviet countermeasures depends on the nature and capability of the weapons systems that would be deployed, the strategy of their application, and the amount of resources that might be committed against the submarine force.

Potential threats to the submarine force fall into several broad categories:

1. barrage attack using nuclear weapons;
2. large area searches, followed by barrage attack;
3. large area searches, followed by attacks using surface ships or aircraft;
4. nuclear explosion generated giant waves (Van Dorn Effect); and
5. trailing of the submarine force, followed by simultaneous attacks on all the submarines.

A barrage attack is a pattern bombing attack, using nuclear weapons. In its simplest form, it is a random pattern bombing of ocean areas in which the Soviets suspect submarines are operating.

A variation of the barrage attack is an area search followed by a barrage attack. If an adversary possessed a search technology that was only able to locate submarines approximately over an extended period of time, then only those areas of ocean in which the approximate locations of submarines were known would be attacked. If the area in which the submarines are localized was small enough, it is possible that the barrage could result in the destruction of the submarine force.

If an adversary possessed still better search technologies, capable of localizing submarines well enough to send out surface ships or planes to attack the submarines, it would be possible to sink the entire force of submarines with conventional weapons or a very small number of nuclear weapons.

Still another way that a force of submarines might be attacked is to detonate large nuclear weapons in sufficiently deep water to generate gigantic waves. If the waves were large enough and the water shallow enough the waves might tumble the submarines, causing sufficient damage to sink them or render them inoperable. The phenomenon associated with the generation of such large waves with nuclear explosions is called the Van Dorn Effect.

If an adversary's ability to search large areas rapidly was inadequate for attacking the force by limited barrage or with surface ships or planes, he might instead choose to trail all the submarines. Once a significant fraction of the submarines were under trail, they could then be attacked at a prearranged time, resulting in the destruction of the submarines and their missiles,

A barrage attack against the entire operating area would require more than 30,000 high-yield nuclear weapons. If the high-yield warheads on the missiles were replaced with a larger number of smaller warheads (i.e., if the adversary fractionated his force) the area of ocean that could be barraged would be no greater.

If the adversary instead chose to generate gigantic waves by detonating large nuclear

weapons in deep ocean waters, the submarines would not be damaged unless they were in certain shallow water areas on the Continental Shelf.

All other means of attacking the force of submarines depend on an ability to detect and localize, or trail, submarines with varying degrees of success. Table 21 lists possible observable that in principle accompany the presence or operation of a submarine, Sensing technologies that could potentially detect the presence of the observable listed in table 21 are listed in tables 22 and 23. These technologies were examined as possible methods for detecting and localizing a fleet of slowly patrolling dispersed ballistic missile submarines. All these technologies were found to fall into one of two broad categories: sensing technologies that do not appear to offer any possibility of detecting submarines effectively enough to be able to threaten the submarine force by area search or trailing; and sensing technologies that could be spoofed, confused, or rendered useless with inexpensive and easy to implement countermeasures.

### Tactical and Strategic Applications of Anti submarine Technologies

It should be noted that many sensing technologies of great use in tactical antisubmarine operations are of little use in the strategic role.

**Table 21.—Submarine Observable**

---

Acoustic radiated sound  
 Acoustic reflected sound  
 Heat (infrared signatures, surface scars from snorkeling submarines, hydrodynamic transport of reactor heat to ocean surface)  
 Electromagnetic disturbances  
 Ocean surface effects (Bernoulli hump, snorkel or periscope wake, trailing wire wakes, microwave reflectivity of the ocean surface)  
 Hydrodynamic wake effects (salinity, temperature, conductivity, density, etc.)  
 Erosion and corrosion products  
 Chemical Effluents  
 Irradiated elements in sea water  
 Magnetic field disturbances  
 Optical reflectivity (blue-green lasers)  
 Luminescence  
 Biological disturbances of marine life

---

SOURCE Office of Technology Assessment

**Table 22.—Acoustic Sensors for Submarine Detection**

---

Submarine sonar systems  
 Active sonars  
 Passive sonars  
 Conformal arrays  
 Hull-mounted arrays  
 Towed arrays  
 Fixed array networks  
 Passive (sonobuoys and arrays)  
 Surface ship sonars  
 Active  
 Standard ship sonars  
 Semiactive  
 High-power low-frequency transmitters in combination with long-towed arrays  
 Passive  
 Hull-mounted arrays  
 Towed arrays  
 Plane, ship, or helicopter deployed sonobuoys  
 Active  
 Semiactive  
 Sound source plus receivers  
 Passive  
 Helicopter sonars  
 Dipping sonars

---

SOURCE Office of Technology Assessment

**Table 23.—Nonacoustic Sensors for Submarine Detection**

---

Infrared systems  
 Snorkeling scars  
 Reactor heat  
 Optical systems  
 Visual observations  
 Snorkles or masts  
 Wakes  
 Near surface effects  
 Blue-green laser  
 Synthetic aperture and pulse compression radars  
 Surface roughness  
 Snorkels or antennas  
 Hydrodynamic wakes  
 Bernoulli hump  
 Sniffing devices  
 Snorkeling effluents  
 Magnetic anomaly detectors  
 Passive microwave radiometers  
 Surface roughness  
 Hydrodynamic wakes  
 Electromagnetic detectors  
 Turbulence sensing systems  
 Trace element detectors  
 Activation product detectors

---

SOURCE Office of Technology Assessment

For example, an attack submarine that is moving at high speed in order to position itself to attack a battlegroup or convoy may be making tens or hundreds of times more noise than that made by a slow-moving ballistic missile submarine. The close proximity of the fast-moving hostile submarine and the large amounts of noise associated with highspeed operations makes the attack submarine susceptible to detection by the battlegroup. If the attack submarine is detected by a passive sonar and it is not possible for the sonar operator to determine the range of the submarine from the battlegroup, a plane or helicopter equipped with a magnetic anomaly detector could be sent out along the direction of the sonar contact to localize the submarine. The aggressive tactics required of the attack submarine result in the submarine increasing its detectability while simultaneously bringing itself within close range of potential adversaries. This circumstance is completely different from that of the ballistic missile submarine.

### Theory of Open Ocean Barrage

A barrage attack is a pattern bombing attack, using nuclear weapons, of ocean areas in which the Soviets suspect submarines to be operating. In the absence of information on the locations of submarines, they would have to barrage millions of square miles of suspected operating area. It is also possible that the Soviets would attempt to gain information on the approximate whereabouts of submarines by using large area search techniques. If, for instance, each submarine in the force could be contacted and localized once a day, during the process of a large area search, then the approximate locations of the submarines would be known within a 24-hour sailing distance of those contact points.

Figure 71 illustrates just such a circumstance. This diagram illustrates the results of a postulated large area search in the Gulf of Alaska that results in the observation and localization of four submarines in a period of 2 days. Upon observing a submarine, the search aircraft notes its location and continues on its search pattern. The submarine is assumed to

be patrolling at 5 knots and may be moving in any direction from the point of contact. The result is that the submarine's location is known with less and less certainty as the submarine continues its patrol. In the diagram, the area of uncertainty associated with the most recently observed submarine is represented by a point. The smallest circle represents the area of uncertainty generated by a submarine observed 10 hours earlier. The next larger circle illustrates the area of uncertainty of a submarine observed the day before and the largest circle represents the area of uncertainty associated with a submarine observed 2 days before.

The ability to perform such large area searches is based on considerably more than just the dedication of military assets. A technology must exist that gives a sufficiently high search rate so that the mean time between submarine localizations is small relative to the time needed for the submarine to generate an area of uncertainty sufficiently large to be impossible to barrage. For example, if a search technology existed that, on the average, was able to localize every submarine in the force every 24 hours, then each submarine would on the average be localized within a circle of radius 120 miles (see fig. 71 for an illustration of the size of the 1-day area of uncertainty generated by a submarine assumed to patrol at an average speed of advance of 5 knots). The submarine would, on the average, be known to be somewhere within a circle of area 45,000 nmi<sup>2</sup>. If the kill radius of a nuclear weapon is of order 5 nmi, then 500 to 600 weapons would be required to assure that the submarine was destroyed.

Of equal importance to large area search capability is a low false alarm rate. If one false alarm were generated per hundred thousand square miles searched, there would be 20 to 30 additional targets that would have to be attacked that were not submarines (assuming the deployment area was of order 2 million to 3 million mi<sup>2</sup>). If the average submarine contact rate were still every 24 hours but there were, in addition, 20 to 30 false alarms among the targets, 10,000 to 15,000 nuclear weapons would

**Figure 71.—Number of Weapons Required to Destroy Submarines That Have Been Sighted Prior to a Preemptive Attack**



Four submarines seen in two days

Speed - 5 knots

Kill radius per weapon - 3.5 nmi

Time since last observation

Just observed -1 RV

10 hr, 7,800 nmi<sup>2</sup>, 196 RVS

1 day, 45,000 nmi<sup>2</sup>, 1,130 RVS

2 days, 181,000 nmi<sup>2</sup>, 4,500 RVS

SOURCE: Office of Technology Assessment

be required to cover the false alarms. Thus, the false alarm rate must be very small or it will be difficult to narrow down the number of targets to a manageable level.

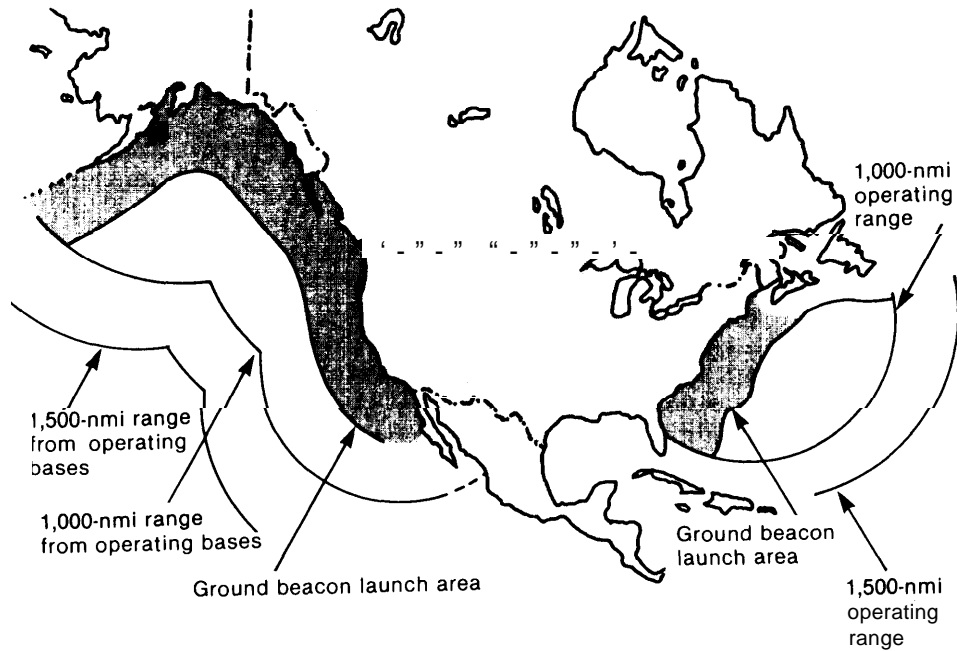
Finally of significance in the barrage attack is the number of warheads available to the adversary for purposes of barrage. If the number of weapons grows to a large enough number, it may be necessary to expand the submarine operating areas or create decoys to increase the number of false targets observed in an area search. For conceptual purposes, an approximate rule of thumb would be 20,000 to 25,000 nuclear weapons are required to barrage a million square miles of deep ocean operating area. In shallow water, the kill radius associated with the underwater detonation of a nuclear weapon is considerably smaller than that in deep water. There is between 70,000 and 90,000 mi<sup>2</sup> of Continental Shelf area (ex-

cluding the Continental Shelf of the Gulf of Mexico but including the shelf area of the Gulf of Alaska) available for submarine operations; a pattern bombing attack of these areas would require between 25,000 and 30,000 nuclear weapons because of the smaller kill radius.

### Open Ocean Barrage With No Information About Submarine Locations

The submarines would operate in an area of ocean sufficiently large so that a significant fraction of them could not be damaged by pattern bombing with nuclear weapons. The deployment areas near the east and west coasts of the United States and the Gulf of Alaska are shown in figure 72. The outer boundaries in the figure are 1,000- and 1,500-nmi arcs from Narragansett Bay, R. I., Anchorage, Alaska, San

Figure 72.—Potential Deployment Area Given 1,000- and 1,500nmi Operating Ranges



SOURCE: Office of Technology Assessment.

Diego, Calif., and the Miller Peninsula, Wash. The exact boundaries of this area could vary significantly with choice of base siting and operational procedures. The operational area would be of the order of 2 million to 3 1/2 million miles.

In testimony given to Congress, Garwin and Drell have suggested that a strategic nuclear weapon detonated at the proper depth in deep water might destroy a submarine at a distance of 5 miles. According to this estimate, an underwater nuclear detonation could destroy submarines within an area of ocean of about 75 mi<sup>2</sup>.

Garwin and Drell have also stated that this damage range could be considerably smaller if the submarine were operating at a shallow depth. If an open ocean barrage were attempted, a large number of missile launches would be observed on early warning sensors. The submarines could be ordered via the VLF radio link to move to shallow depths where the effects of underwater nuclear explosions would be much shorter range. If this move-

ment were to occur, the effectiveness of the barrage would be substantially reduced relative to the numbers quoted in the paragraph above.

Assuming the Soviets could deliver as many ICBM warheads against MX-carrying submarines as they could against a land-based MX system (i. e., 2,300 warheads) and the submarine damage range is 5 nmi, submarines operating within an area of 200,000 miles of ocean could be destroyed or rendered inoperable by a nuclear barrage attack. This attack would result in the loss of two to three submarines and their missiles if the submarine operating area was limited to only 3 million mi<sup>2</sup>.

### Open Ocean Barrage After Detection of Snorkeling Submarines

If a sensing technology with a very high search rate and a very low false alarm rate were available, it is conceivable that submarines could be contacted often enough that the entire operating area would not have to be

barraged in order to sink the submarines. Assume a search technology capable of detecting submarines only when they are snorkeling. This device could be a passive sonar detecting the diesel engine tonals or an airborne radar detecting a snorkel mast. If 50 submarines were uniformly dispersed within 3 million  $\text{mi}^2$  of ocean, one submarine could be expected in every 60,000  $\text{nmi}^2$ .

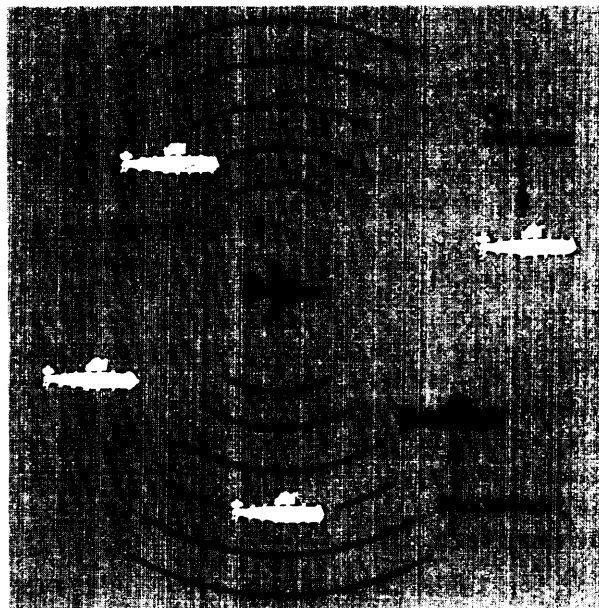
Figure 73 illustrates the concept of a large area search as it would apply to an aircraft searching for snorkeling submarines, since the sonar ship would be unlikely to detect a submarine operating on batteries. The same diagram could apply to a sonar ship. Although the sonar ship would move more slowly than an aircraft, it is possible that its detection range would be greater. The result might be that both the sonar ship and the aircraft could have the same search rate. As illustrated, if the search platform passes within detection range of a submarine, the submarine may not be snorkeling and would therefore not be detected.

Also worthy of note is that the submarine could have the ability to counterdetect the search platform before the search platform is close enough to detect the submarine. This discovery could occur if the search platform is a fast-moving surface ship (that makes a lot of noise) or a radar plane (that emits a signal that is detectable at a greater distance than the signal reflected from the snorkel).

In order to develop a more quantitative picture of the possible outcome of a determined large area search effort, the following assumptions are made about a large area search effort:

1. a search technique is available that can search 14,000  $\text{nmi}^2$  per hour. This method might be an aircraft that flies at 350 knots and can observe snorkels at 20 nmi on either side of its flight track or a long range sonar system that is towed at 14 knots and can detect snorkeling tonals at 500 nmi in each direction;
2. submarines snorkel 10 percent of the time;

**Figure 73.—Large Area Search With Technology That Can Only Detect Snorkeling Submarines**



SOURCE: Office of Technology Assessment

3. the probability of detecting a submarine when it is in range is 50 percent;
4. the number of false detections is infinitesimal relative to the number of valid detections, even though extremely large regions of ocean are being searched rapidly; and
5. there are 100 units searching the 3-million-nmi deployment area 24 hours per day 365 days per year.

These assumptions lead to a detection rate of one submarine every hour by the 100 searching units in the 3-million-nmi<sup>2</sup> deployment area.

If the position of each of these submarines was recorded, then 1 hour after being detected a submarine could be anywhere within a 5-mile radius of its original position. At 2 hours the distance will have grown to 10 miles, at 3 hours 15 miles, and so on.

The Soviet Union could then pattern bomb each area determined by the patrol radius of a previously sighted submarine. If nuclear weapons with kill radius of 5 miles were used, one



weapon would be needed to guarantee the destruction of the submarine seen 1 hour earlier, four weapons would be needed for the one seen 2 hours earlier, nine for the one seen 3 hours earlier, sixteen for 4 hours, and so on. To destroy 20 submarines, 2,870 weapons would be needed, 5,525 would be needed to destroy 25 submarines and 9,455 weapons would be needed to destroy **30 submarines**.

**It should be noted that passive sonars** would not be able to localize submarines at such great distances since fluctuations in sound transmission in the ocean make measuring distances impossible. Cross fixing with multiple units would almost never occur because of fluctuations in the **acoustic transmission of sound** in the ocean. It would be a common circumstance that the sound would reach one of the sonar units, but not the other.

If the units were aircraft searching with radar, they would have to make long transits in order to remain on station. The aircraft would have to transit from bases to the submarine deployment areas, search the areas, transit back home, and be refueled and repaired for the next transit out. In order to maintain one aircraft on station continuously, three to six aircraft would be needed. Some typical base loss factors (i. e., the number of platforms needed per platform continuously on station) are shown in table 24 for turboprop aircraft transiting from Soviet bases to operating areas.

Finally, it is absolutely necessary that false alarm rates be extremely low in spite of the fact that vast areas of ocean must be searched at a very high rate. As will be illustrated in the discussion to follow, even low or moderate false alarm rates would render the most effective area search useless.

### Searches With Technologies That Observe Non snorkeling Submarines

It is conceivable that a search could be performed using a technology that was able to detect the presence of a submarine whether or not it is snorkeling. Such technologies might involve the use of active acoustic technologies or magnetic anomaly detectors. The nature of these technologies is that they are short range. For purposes of discussion it will be arbitrarily assumed that the detection range of these technologies would be about 5 miles. This assumption should not be taken as a true estimate of capabilities since that would depend on the acoustic properties of ocean areas, magnetic storms, sensitivity of sensors, properties of the target submarine, etc.

Since the sensors being discussed in this case do not require the submarine to be snorkeling to be detected, all submarines within the detection range of the sensor could be assumed to be detected. If it is assumed that an aircraft must travel more slowly for magnetic

**Table 24.—Operational Factors Affecting Radar Search of Submarine Deployment Areas<sup>a</sup>**

Operating area or naval facility	Soviet naval or air base	Distance (nmi)	Time on station (hours) <sup>b</sup>	Transiting time (hours) <sup>c</sup>
Norfolk	Murmansk	4300	Not possible	—
Norfolk	Cuba	870	6.6	4.1
Charleston	Murmansk	4600	Not possible	—
Charleston	Cuba	610	7.2	2.9
San Diego	Petropavlosk	3600	0.2	16.9
Seattle	Petropavlosk	2800	2.1	13.2
Northwest Atlantic	Cuba	1400	5.4	6.6
Northeast Pacific	Anadyr	2300	3.3	10.8

<sup>a</sup>Time on station and transit assumes BEAR bomber configured for long-range Surveillance.

<sup>b</sup>High altitude transit followed by low altitude search

<sup>c</sup>Transit speed of 425 knots Transit times include transit to search area and transit back to base.

SOURCE: Off Ice of Technology Assessment

detection (say 100 knots) then it would be able to detect every submarine within a 5-mile radius of it as it moves along. This assumption means the aircraft could search a 1,000 nmi area each hour it is operating (assuming a probability of detection of one when a submarine is encountered). In order to achieve the same detection rate that the aircraft in the earlier example achieved, 7 platforms equipped with magnetic anomaly detectors would have to be substituted for each of the radar aircraft. Thus, it would require 700 aircraft on station continuously, which means a fleet of 2,100 to 4,200 aircraft dedicated only to search of the deployment area. If weather did not interfere with the search and submarines did not take advantage of surveillance data supplied through VLF channels to avoid search platforms, then 5,525 warheads might be needed in addition to these forces in order to destroy half of the postulated force of 50 submarines.

Active acoustic search might be substituted for passive. Since the range assumed is 5 miles, and ships might travel at only 20 knots, it would require 35 ships to replace every radar

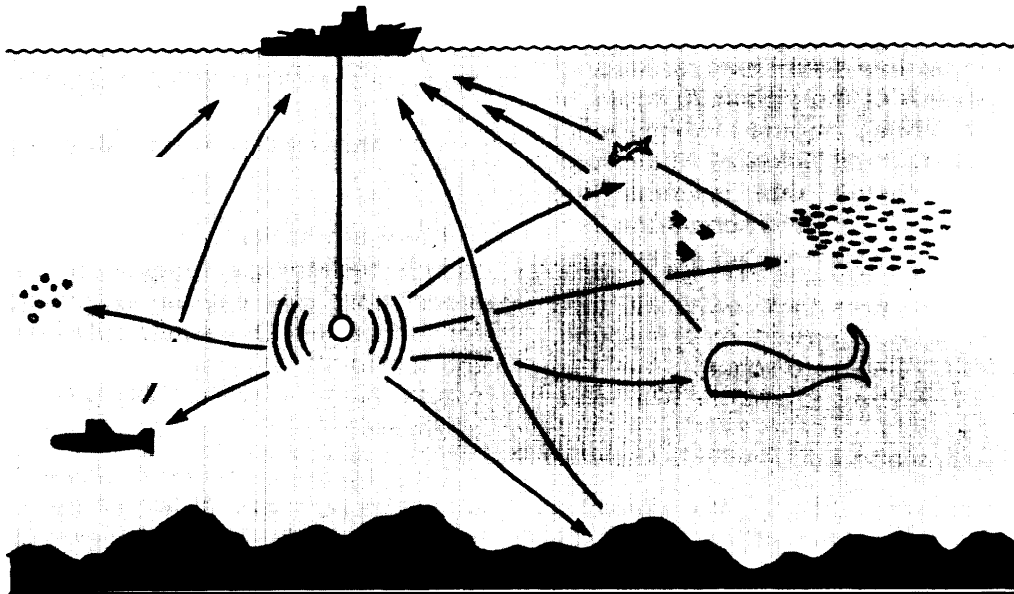
plane in the first example (assuming a probability of detection of one if a submarine is within the detection range)

A serious problem associated with active acoustic search would be the problem of false targets. Simply stated, a false target is an underwater phenomenon that generates a sonar signal similar to that of a submarine. The existence of false targets generates an additional complexity in the large area search problem that can catastrophically degrade the effectiveness of the search effort:

1. nonsubmarine targets may be incorrectly identified and tracked as possible submarine targets, and
2. submarine targets may be incorrectly identified as nonsubmarine targets,

Figure 74 illustrates the circumstance of an active acoustic search. The surface ship has a sound transducer that emits sound that scatters off objects in the water. Unfortunately for the searcher, sound not only bounces off the submarine, but it also bounces off temperature boundaries in the water, bubbles, plankton,

**Figure 74.—Sources of Reverberation That Limit the Capability of High-Powered Active Sonars**



SOURCE: Office of Technology Assessment.

schools of fish, the ocean bottom, and the ocean surface. In particular, the sound that reflects back and forth between the surface and the bottom of the ocean results in an extended and very intense echo. Since the surface area of the ocean floor and ocean surface are so great relative to the surface area presented by a submarine target, the initial sound impulse of the sonar returns like the deafening echo from the walls of a cavern. From the point of view of the sonar operator, each sound pulse is reflected by a myriad of false targets and deafening echoes from the "walls" of the ocean. From this set of confused data, sound reflected from the hull of a submarine must be identified from sound reflected from other "false targets" that could potentially be submarines.

Figure 75 is a chart of the number of whale targets over 30 ft in length per 1,000 nmi that could potentially be mistaken for sonar targets in the Western North Atlantic during the month of September. Of all biological targets in the ocean, whales are the most difficult to distinguish from submarines on sonar. These marine animals resemble submarines in size, speed, acoustic characteristics, and certain modes of behavior. When two or more whales occur together, as they frequently do, they represent a very significant sonar target. Under normal conditions whales swim at 4 to 8 knots, well within the range of submarine patrol speeds, and may flee from man or natural predator-s at speeds of more than 20 knots. In addition to returning submarine like sonar echoes, the power-fultail flukes of whales produce swimming sounds that resemble the screw (i.e., propeller) noise of a submarine.

Smaller fish can also have very large sonar cross sections because they have air-filled swim bladders that intensely reflect sound. When these fish collect into schools, they can present very convincing submarine-like sonar signals.

If the submarine is moving, the reflected sound from the hull will be slightly shifted in frequency relative to sound reflected from stationary objects in the water. The frequency shifted sound might be separable from other

sounds provided the submarine didn't slow down to reduce the the size of the frequency shift. If the sonar platform speeded up in order to get a higher search rate, the sound reflected from the "walls" of the ocean would be shifted in frequency. This would make it very difficult to separate the frequency shifted "echo" from real signals generated by moving targets.

If a submarine counterdetected an adversary performing an active acoustic search, the submarine could also turn toward or away from the source in order to reduce the amount of reflected sound from the hull. The sound reflection would be reduced because the intensity of sound reflected back toward the sound source would be roughly proportional to the cross sectional area the submarine presents to the source. Since the cross sectional area would be reduced by about a factor of 10, the sound reflected back to the acoustic searcher would also be reduced by a factor of 10. In addition, since the front or back of the submarine has a more highly curved surface than the side, sound will be more diffusely reflected from the front or back of the submarine than it would be if it were reflected from the side. This same principle of reducing detectability by causing reflections to be diffuse is also of use in lowering the radar cross sections of aircraft.

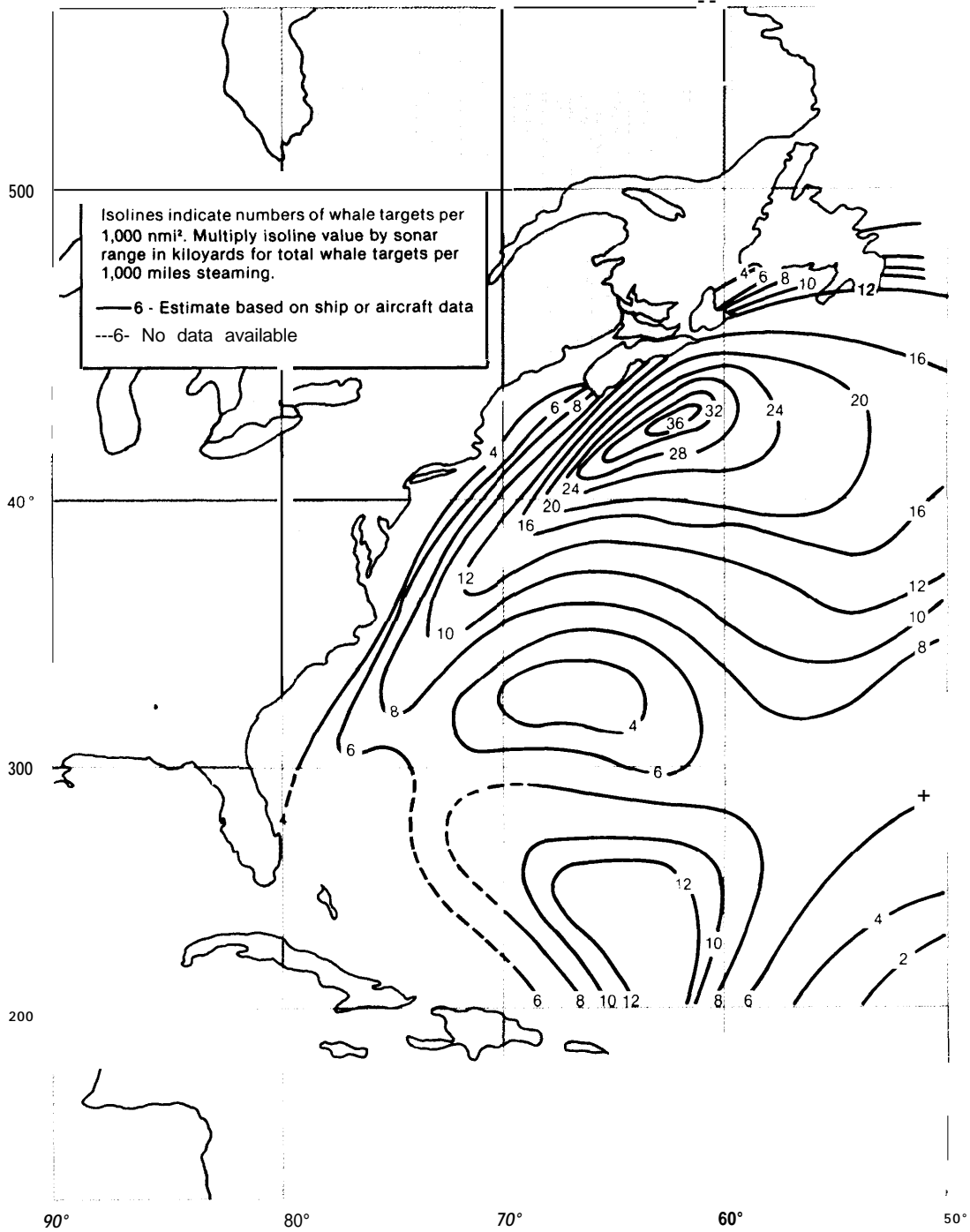
Thus, there are many problems of both a technical and operational nature that seriously hamper active acoustic technologies as a means of searching out submarines.

### Increased Range Acoustic Technologies

There are basically two ways that acoustic search technologies might in principle be made more efficient for long-range searches for submarines. One way would be to increase the sensitivity of passive acoustics, the other would be to increase the power of active acoustics.

Unfortunately, the more power that active acoustics puts into the water, the more sound reverberates through the ocean blinding the ability of the acoustic system to the small signals from a submarine. Active acoustics can

Figure — Potential Whale Sonar Targets (Western North Atlantic)



be very effective against submarines at short range, simply because the signal from a nearby submarine is so much more intense than background signals. However, as the submarine moves away from the active sonar, its intensity will drop at least with the fourth power of range. Thus, if the submarine is twice as far away, the signal from it will be 16 times weaker ( $2^4 = 16^*$ ). The background reflections from the ocean surface and bottom will not change. Hence, it becomes more and more difficult to distinguish reflections from the hull of the submarine from the unwanted ocean reverberations. Increasing the power of the sonar only increases the unwanted reverberation along with the wanted signal. Thus, the nature of sound propagation in the ocean presents a fundamental limit to the increased capability of active acoustics.

Passive acoustics has similar barriers to increased performance. Passive acoustic sonars must discriminate the sound of a submarine from all the other sounds in the ocean. The total radiated acoustic power of some foreign modern submarines is measured in milliwatts. In a calm sea, the sound from one of these submarines at 100 yd would be equal to that of ocean wave and shipping background. No matter how one improves the quality of detectors and signal processing, the quietness of modern submarines and the noisiness of the ocean set fundamental barriers on the capability of long-range sonars against slowly patrolling submarines,

---

\* The fourth power law comes about as follows Sound emitted from the sonar source and sound reflected from the submarine on the average spread spherically at short range The intensity of a sound wave that spreads spherically from a source point Will decrease as the square of the distance from that point The intensity of sound that ultimately arrive back at the search platform is first diminished by a factor of distance squared before reaching the submarine, and then diminished by another factor of distance squared after it is reflected by the hull of the submarine Thus, as the distance between the submarine and the search platform increases, the Intensity of the signal that ultimately arrives back at the search platform diminishes at least as fast as the fourth power of that distance. If the effects of sound absorption are also include, the intensity of the signal received from the submarine will decreased even faster fourth power law as the distance between submarine and search platform increases

## Increased Radar Search Using Satellites

Since large area search against snorkeling submarines is likely to be limited by the endurance of aircraft and range of radars, it is conceivable that other more exotic platforms could be used for large area search. A high-resolution radar (i. e., synthetic aperture radar) has been flown on a satellite (*Seasat-A* had an L-band (25-cm wavelength) synthetic aperture radar) that has obtained a resolution of 25 m from altitudes of order 500 nmi. In principle, significantly higher resolutions are possible. *Seasat* was able to observe ships on the surface of the ocean with sufficient accuracy that image processing could result in crude identification of ship characteristics. *Seasat* was, under certain conditions, also able to observe the hydrodynamic wakes of ships and the surface roughness of the ocean. Remarkable pictures of internal ocean waves, that impress themselves through hydrodynamic coupling on the roughness of the oceans surface, have been observed from *Seasat* radar reflectivity data. It is reasonable to expect that higher resolution radars can and will be built that could be capable of observing snorkeling submarines.

As an example of the surveillance capability of a low resolution synthetic aperture radar system, two photographs obtained through the courtesy of M. L. Bryan of the Jet Propulsion Laboratory staff are presented in figure 76 Photograph A was taken in the Bering Sea Test as part of the Fisheries Imaging Radar Surveillance Test Program. This photograph was taken using an airplane equipped with an L band synthetic aperture radar. The small spot on the lower left portion of the photograph are small Japanese fishing boats operating a purse seiner (a large vertically suspended fishing net) and the larger bright spots are mother ships Photograph B was taken on *Seasat A* orbit 1291. It is the area off Newport Beach in Orange County in southern California. The white streaks in the photograph are probably ships. The bright and dark areas of ocean are due to the changing roughness of the ocean surface and the angle of the radar return. Tl-multi ridged structures within some of th-

Figure 76.— Fishing Vessel Monitoring (JPL (L-band) synthetic aperture imaging radar)

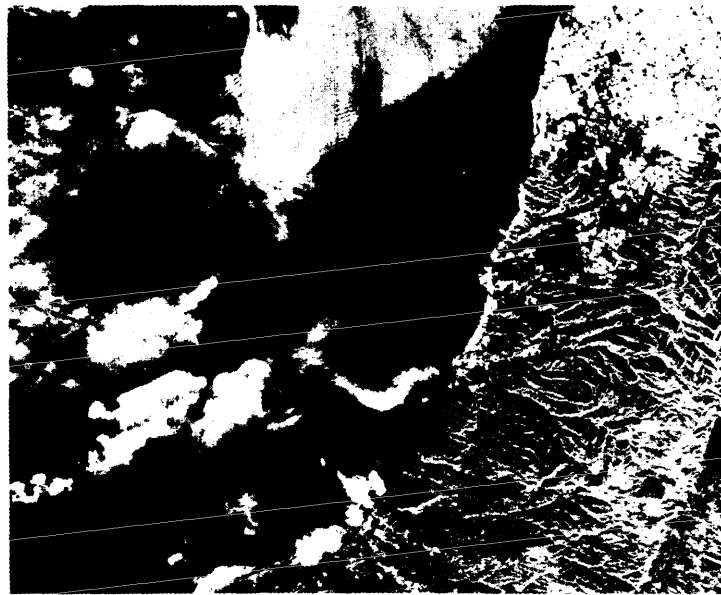
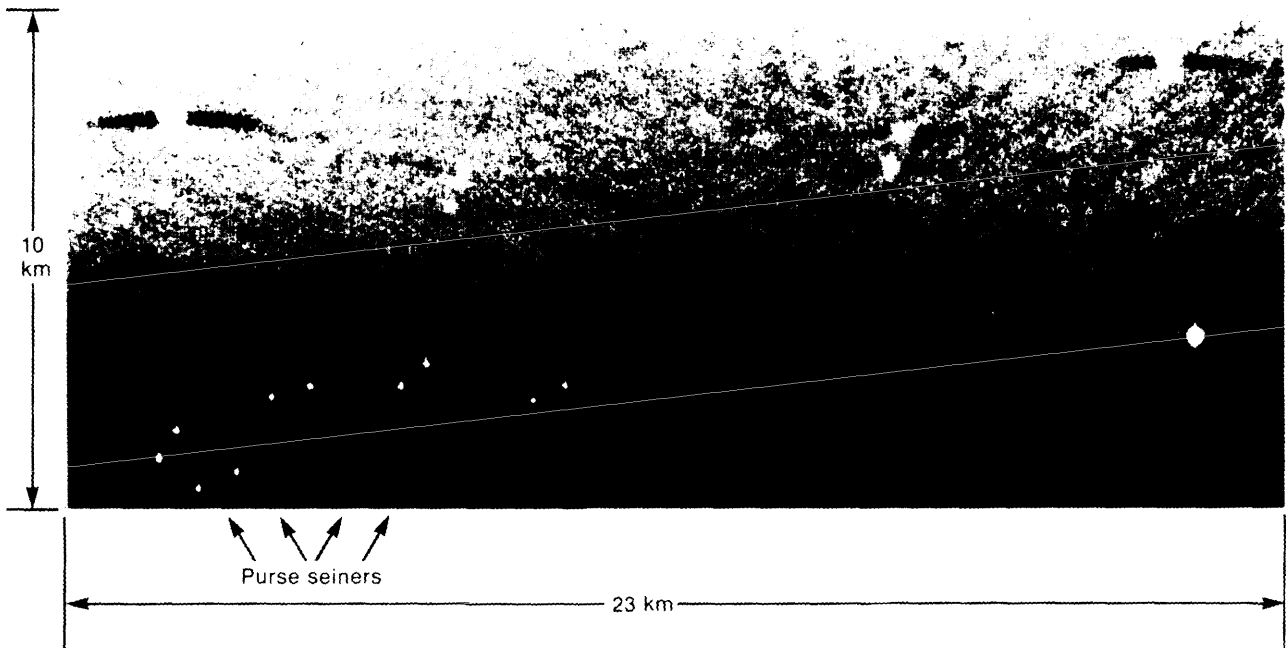


Photo credits: Japanese "Purse Seiners" and mother vessels. Fisheries Imaging Radar Surveillance Test. Bering Sea Test Report, NASA courtesy of M. Leonard Bryan, JPL Technical Staff.

Seasat-A synthetic aperture radar photograph

bright regions are surface manifestations of internal ocean waves that result in changes of the surface roughness and the radar reflectivity.

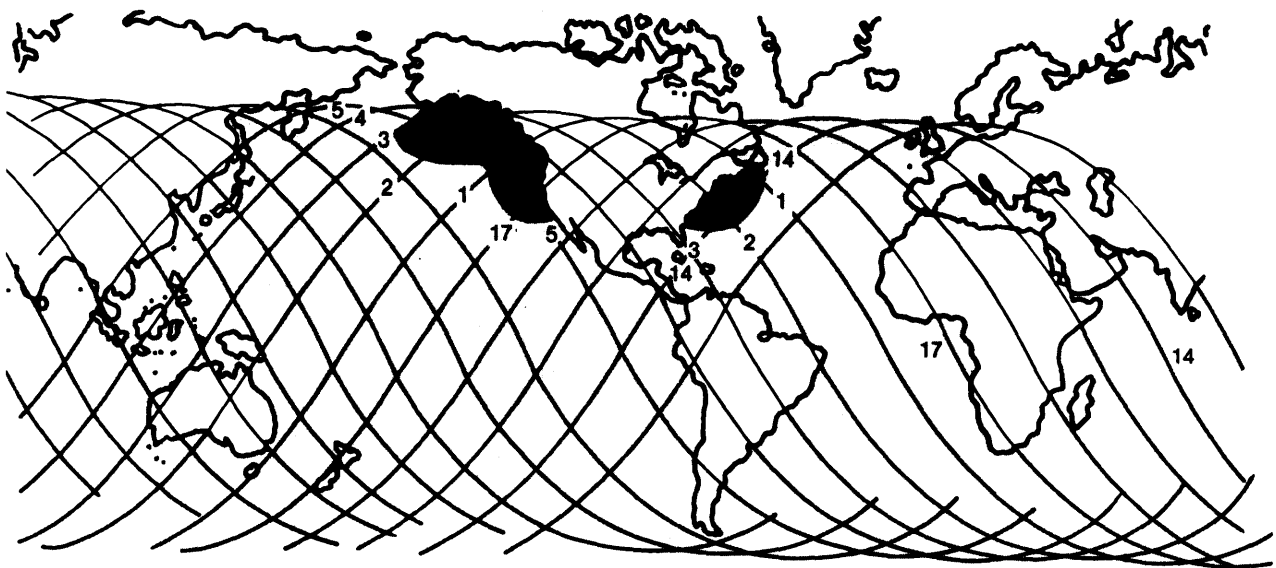
A high-resolution radar system searching a vast and constantly shifting ocean surface could have a very high false alarm rate due to random waves reflecting additional intensity. In addition, the capability of the radar would also vary dramatically with the sea state (i. e., size of waves and roughness of the ocean), since the ocean surface creates an intense background of reflected clutter that can be very difficult to filter out.

The false target rate due to random wave motion might be dramatically reduced by having the radar "repoint" at the suspicious target. However, such a radar would require considerably greater amounts of signal processing in a technique already limited by signal

processing capabilities. Nevertheless, it is prudent to assume that signal processing and radars could be sufficiently improved to observe snorkeling submarines with a high degree of confidence.

Figure 77 shows the ground track of a satellite that is at an altitude of 162 nmi and whose orbit is inclined at 60° to the equator. This orbit is similar to that used by the Soviet Cosmos 954 radar satellite that entered the upper atmosphere over Canada on January 24, 1978 (the actual orbital inclination of Cosmos 954 was 65°). Note from the figure that the satellite coverage is predictably intermittent. [uring the 1.5-hour satellite period the ground track advances 22.50 on the Earth below and the search pattern shifts to the west (note the orbits labeled one, two and three). After 16 cycles the satellite arrives over the same point on the Earth's surface but it will only have

Figure 77.—Ground Track of Radar Search Satellite



60° inclination  
160-170 nmi altitude  
1.5-1.6 hr period

overflow the deployment area on six or seven orbits. The satellite would spend about 4 to 5 minutes over the deployment area during each of the six to seven orbits. Thus, one satellite spends no more than 25 to 35 minutes per day over the deployment area. If two satellites are in the same orbit but separated in phase by 180°, they would follow one another by 45 minutes (i.e., by half of the 90-minute orbital period). Thus, for six or seven orbits a day, satellites would be over the deployment area once every 45 minutes. Six to seven orbits translates to 9 hours per day (six orbits times 1.5-hour orbital period) when satellites could be expected overhead every 45 minutes. If two other planes of orbits with two satellites each are staggered so they will not overlap the first plane of two satellites, then eight satellites would be required to cover the deployment area 8 minutes every 90 minutes. Covering the area for 16 minutes every 90 minutes would require 12 satellites and 32 minutes out of every 90 minutes would require 24 satellites. It would thus appear that in order to cover the deployment area 30 percent of the time, of order 24 satellites would be required.

If an eight-satellite constellation of radar satellites was placed in orbit to cover the deployment area, submarines could not snorkel for periods of longer than 40 minutes before it would be necessary to secure snorkeling to hide from a satellite. If 150 minutes of snorkeling were needed every day, eight satellites would force the submarines to snorkel for four periods of 40 minutes each and 16 satellites would drive the submarines to eight or nine periods of 18 minutes each. If observation by a constellation of eight radar satellites had to be avoided, the normal 150 minutes continuous snorkeling period would have to be extended by 12 to 16 minutes due to the three to four periods (of length 4 minutes each) the satellites would be overhead. For 16 satellites the period could be extended to 180 minutes and for 32 satellites it could be extended to more than 200 minutes. The submarines would therefore have to be designed so they could snorkel for many successive short intervals. Current diesel-electric submarines may not be capable of this type of operation (modern sub-

marines may be able to interrupt snorkeling for periods as short as the necessary 4-minute periods without serious losses in snorkeling efficiency, but data on such procedures are not currently available.) The power management system of the small submarine might therefore have to be configured so that the submarines could snorkel efficiently for short periods of time interrupted by still shorter periods of battery operation. This approach would allow them to avoid surveillance from a constellation of radar satellites and would only marginally affect the overall length of the snorkeling period.

### Countermeasures to Radar Satellites

If radar satellites were considered to be a serious enough threat, Garwin and Drell have suggested that the ocean could be seeded with radar reflecting objects that would be indistinguishable from snorkels.

If many false snorkel targets were deployed in waters near the continental United States, it could make it easier for Soviet diesel-electric submarines to operate in U.S. waters because U.S. naval forces could have as much difficulty distinguishing false snorkels as would the radar satellites. If the snorkels could not be designed to be distinguishable to U.S. naval forces, but not to space-based radars, such a strategic countermeasure could disrupt our own tactical operations.

Another possibility would be jamming the radar satellites from ground- or sea-based stations. However, jamming could have international implications. Since the intermittent nature of the satellite orbits makes avoidance of detection straightforward, neither of these countermeasures would likely be preferable to intermittent snorkeling.

### War of Attrition

As mentioned in the introductory remarks to this section, the strategy associated with a given surveillance capability, coupled with available military resources, could affect the outcome of a preemptive attack on the force of submarines. It is therefore possible that the surveillance capability postulated in the sec-



tion on Open Ocean Barrage After Detection of Snorkeling Submarines could be used to fight a "war of attrition" rather than attacking in one massive barrage. A "war of attrition" approach to destroying the submarine force would simply involve immediate attacks on the submarines whenever a snorkeling submarine is observed. The outcome of this type of attack would be considerably different from the method discussed earlier of constant surveillance followed by a massive barrage attack. The time period over which the attack would take place would be days or weeks, rather than fractions of an hour. Nevertheless, in order to assess the seriousness of such a threat, it is useful to get a sense of that time scale.

Let us assume that the Soviet Union is able to keep 100 planes on station over a northwest Atlantic operating area. This deployment would require the commitment of a fleet of between 300 and 600 planes constantly flying the 1,400 nmi transits to and from the operating bases in Cuba. Assume for simplicity that all the submarines are operating in a 3-million-mi operating area in the Northwest Atlantic. Then as estimated in the previous section, one submarine should be observed every hour of operation.

For purposes of discussion, assume that each time a submarine is sighted it is attacked and sunk, and continental based U.S. forces do not react to this action at any point during the process. It could then be expected that approximately half the force of 50 submarines would be destroyed in the first day. Since there now would be half as many submarines distributed throughout the deployment area, the rate at which submarines would be contacted and destroyed the next day would drop by two. This would then result in half the surviving submarines (about 12 submarines) being destroyed in the next day of operation. On the third day, the rate of contacts would drop again by two and only six submarines would be left. This kind of circumstance is called a "war of attrition" and was very successful against submarines in the North Atlantic during World War I.

Another possibility is that a submarine is observed once every hour but only half the time the attack on the submarine results in its destruction. Then one fourth of the submarines are destroyed the first day (about 12 submarines), another 9 are destroyed during the second day's operations, 7 the third day, 6 the fourth day, 4 the fifth day, etc. Thus, 5 days of operations results in the destruction of 38 of the 50 submarines as compared to the previous example where 43 submarines were destroyed in three days (it would take 7 days to destroy 43 submarines using the assumptions in the current example).

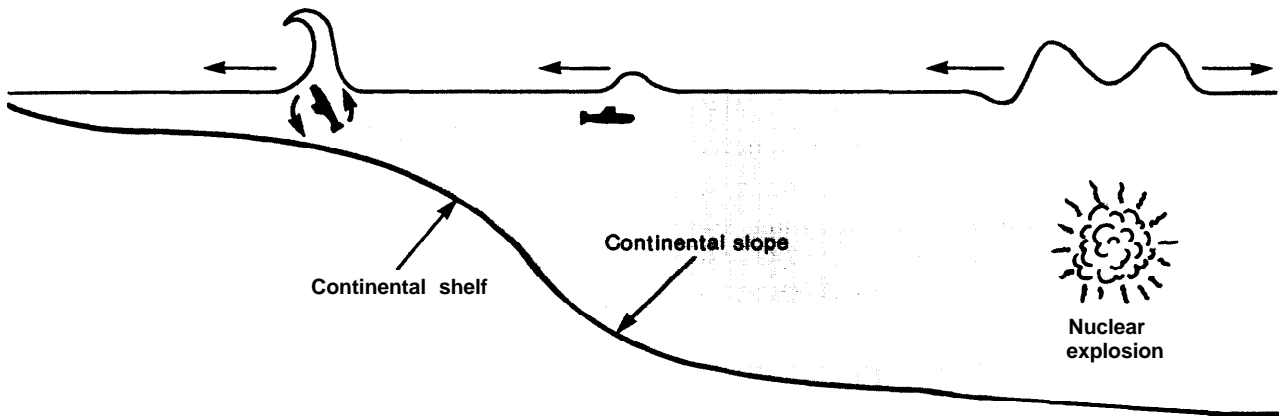
The "war of attrition" scenario would require that the planes carry sufficient armaments to engage and sink submarines with a high probability. It would also require that large relatively defenseless surveillance craft could continuously transit the 1,400-mile route between Cuba and the submarine operating areas, carrying out attacks on U. S. submarines in airspace near the coast of the continental United States, unopposed by American air and sea forces. Another assumption is that submarines could not, and would not, defend themselves with the aid of decoys or underwater to air missiles.

### Van Dorn Effect

The Van Dorn Effect is the creation of extremely high ocean waves over large areas of a continental shelf by an appropriately placed multi megaton nuclear detonation. The physical basis for the Van Dorn Effect is as follows (see fig. 78). A wave created by an underwater explosion in uniform, deep water will diverge radially until it moves into shallow water. When the water becomes shallow enough the wave energy is funneled into a smaller volume of water and the wave height grows in height relative to the height it would have had in deep water. The shape of the Continental Shelf off the eastern coast of the United States is sufficiently steep for an absolute increase in wave height.

There is considerable uncertainty associated with the generation of Van Dorn waves. The

Figure 78.—Van Dorn Effect



SOURCE Office of Technology Assessment

curvature, steepness, and bottom characteristics (i.e., sand or rock) of the continental slope could effect the size and formation of waves at different areas of the coast. The degree of underwater motion that submarines are likely to be able to tolerate without losing their ability to launch missiles is also uncertain.

If a submarine were in sufficiently shallow water, the water motion at the bottom of these giant waves would make it unlikely that the submarine would survive in good enough condition to be able to launch ballistic missiles. If the submarine were operating off the Continental Shelf, the water would always be deep enough that the Van Dorn Effect would not be a threat. The Van Dorn Effect is therefore not a problem for submarines operating off the Continental Shelf.

Because the nuclear explosions would have to be generated in sufficiently deep water to generate Van Dorn waves in the shallow water, there would be several hours' warning before the arrival of these waves. If any submarines were operating in water too shallow to escape the effect, and a Van Dorn attack were diagnosed quickly, several hours would be available for NCA to decide to launch missiles at risk.

### Theory of Trailing

It is conceivable that a determined adversary could review the method of continuous surveillance followed by barrage and determine that the likelihood of success is small. The adversary might be particularly discouraged after a review of the diversity, effectiveness, and cost of countermeasures relative to that of his search and destroy effort. It might therefore be concluded that an effort to continuously trail the submarine force might be more likely to meet with success.

To successfully trail a submarine, it is necessary to have a device capable of sensing the submarine with sufficient effectiveness that some estimate of the position of the submarine relative to that of the trailer can be maintained. It is also necessary that the device be difficult to spoof or jam and that it not be susceptible to simple countermeasures.

There are very few observables associated with the presence and operation of submarines that can be used to detect and track them. The most effective and reliable of these, like magnetic anomaly detection, tend to be very short range and cannot be operated too closely to a platform (like a surface ship or sub-

marine) that has its own magnetic signature. Longer range techniques (like sonar) tend to be subject to the constantly changing acoustic properties of the ocean. Acoustic trailing operations are further complicated by the possibility that the submarine could move into sound ducts, channels, and shadow zones, as a means of suddenly "disappearing" from the view of the trailer. These ubiquitous sound ducts, channels, and shadow zones are created by in homogeneous ocean waters.

A final serious problem confronting the trailer is the possibility the submarine will deploy decoys, jammers, and/or spoofers to further complicate the problems of the trailer. Nevertheless, it is useful to examine some of the possibilities of trailing as a threat to the force of small submarines.

The problem of trailing the submarine force can be broken into three major areas of analysis:

1. initiating the trail,
2. maintaining the trail, and
3. destroying the submarine.

Once the submarine is within a few thousand yards, it is assumed that it can be destroyed with a probability of one with conventional means. This extraordinarily optimistic assumption presumes that the submarine under attack takes no evasive actions and uses no devices to confuse homing torpedoes or other devices and that the weapon used against the submarine is 100-percent reliable.

According to these assumptions, the success or failure of the trailing operation would only depend on the ability to establish trail, and the ability to maintain trail for a long enough period of time that a significant fraction of the submarine force is on the average localized. Two extreme cases are useful to examine in order to understand the significance of an ability to establish and to maintain trail as separate elements of the trailing problem:

1. The probability of establishing trail is one, but the mean time a trail is held varies,
2. The probability of establishing a trail is small, but the trail, once established, is

not broken for the remainder of the submarine's at-sea period,

In case 1, for example, if the submarines were always picked up successfully as they egressed from port, then the average number of submarines under trail would be equal to the percentage of time each submarine was held in trail during its patrol. For instance, if the submarines had a 60-day at-sea patrol and the trail could be maintained for a period of 10 days, then one-sixth of the submarines would be, on the average, under trail.

In case 2, the fraction of submarines successfully trailed is determined by the number of submarines for which a trail was successfully initiated. In this case, if a trail were successfully established on egress from port one-sixth of the time, and maintained for the entire at-sea period, then one-sixth of the fleet would be under trail at all times,

If one combines case one and two, and assumes that one-sixth of the submarines have trails established on them as they egress from port, and one-sixth of those submarines are maintained on trail (because they are trailed on the average for 10 days out of 60), then one-thirty-sixth of the submarines (i. e., less than 3 percent) can be expected to be under continuous trail. It is clear that both the ability to maintain trail and the ability to establish trail are extremely important if there is to be any possibility of maintaining contact with a significant fraction of the force,

A more complete analysis of the trailing problem would include probabilities that trails are established, broken, and reestablished. In the assessment that includes the possibility that a lost trail is reestablished, the possible use of multiple sonars and magnetic anomaly detectors, surface ships using active and passive sonar systems, etc., must also be included. In such a case, if the target submarine is recontacted by a search unit other than the trailing unit (perhaps by a helicopter) the probability that the search unit successfully hands the contact back to the trailing unit (which would have to be a ship or submarine in order to have endurance similar to the target) must

also be included in the analysis). Simulations accounting for such complexity have been performed. The models are technically complex and the results of the analysis are consistent with conclusions drawn from insights gained by examining cases 1 and 2. Since no new insights are gained with the additional complexity, and the models are mathematically complex, these models will not be presented or discussed here.

### Establishment of Trail at Port Egress

In order to establish a trail, it is necessary to know the whereabouts of the submarine within a sufficiently small area of ocean that the submarine can be localized well enough to begin trailing operations. As discussed in other sections, no technology has been identified that appears to provide the ability to effectively search large areas of ocean. Given this circumstance, the trailer would have to seriously consider attempting to trail at port egress, where submarines are initially localized, if there is to be any hope of success.

The trailer would have to use either an acoustic or nonacoustic sensing technology to detect and follow the submarine. This sensing technology would have to be both reliable and difficult to counter. Since trailing operations would have to be initiated at port egress, where substantial U.S. assets would be available to help assure egress, the sensing technology would also have to be unjammable and resistant to spoofing from electronically equipped tugboats, submarines, or surface combatants that might aid in the egress.

The trailing of one submarine by another could be viewed as somewhat similar to the trailing of a plane by a homing missile. The homing missile would either have to passively sense some observable of the aircraft like heat from the engine, or actively illuminate the aircraft as with a radar. If the trailing missile is heat-seeking, the aircraft can disperse flares which the missile is unable to distinguish from the aircrafts engines. If the missile is radar-seeking, the aircraft can disperse chaff to create false radar targets to confuse the radar.

Another measure could simply be to jam the radar (which, depending on the radar, might not be so simple). Still another measure would be for the aircraft to dispense a self-powered decoy that would retransmit the radar signal from the trailing missile in a way that would make the plane and the decoy indistinguishable to the radar. Such a device (called the Quail) was deployed in limited numbers during the 1960's on B-52s as an aid for use in confusing Soviet radars.

Such ideas have been applied in naval warfare as well. During the Battle of the Atlantic, the Germans deployed an acoustic homing torpedo called the Zaunkoning. The Allied countermeasures was to have convoy escorts stream noise emitting "Foxers" to create false targets and jam the acoustic homing torpedo's sensing system.

If there were an attempt to trail a submarine using passive sonar, for instance, trail could be broken through the clever use of a "Foxer"-like device. Such an operation could be done as follows: A submarine being trailed may deploy a small device that makes a sound similar to the submarine. As the submarine proceeds forward, the device could be slowly played out behind the submarine, making it appear to the trailer that the submarine is moving more slowly than it actually is. The trailer would then have to slow down in order to avoid risking a collision, resulting in an increased distance between the trailing and the trailed submarines. The device could also slowly increase the intensity of the simulated submarine sound, further convincing the trailer to increase his distance between him and his potential adversary. At the appropriate time, the line could then be cut or the trailing device shut off. The trailer would only know that the submarine had disappeared from sonar contact.

A most likely technology of use to a trailer would be an active or passive sonar. Active sonar at close range can be quite reliable (remember the distance to the fourth power signal to noise relation). A problem with active sonar is that the trailer is more vulnerable to attack than the trailed, since the sonar is broadcasting its own position.

Passive sonar is preferable to active since the trailer does not make himself quite so vulnerable to preemptive action or counter-maneuvers. However, if the submarine is quiet enough, it will be exceedingly difficult to trail by passive means.

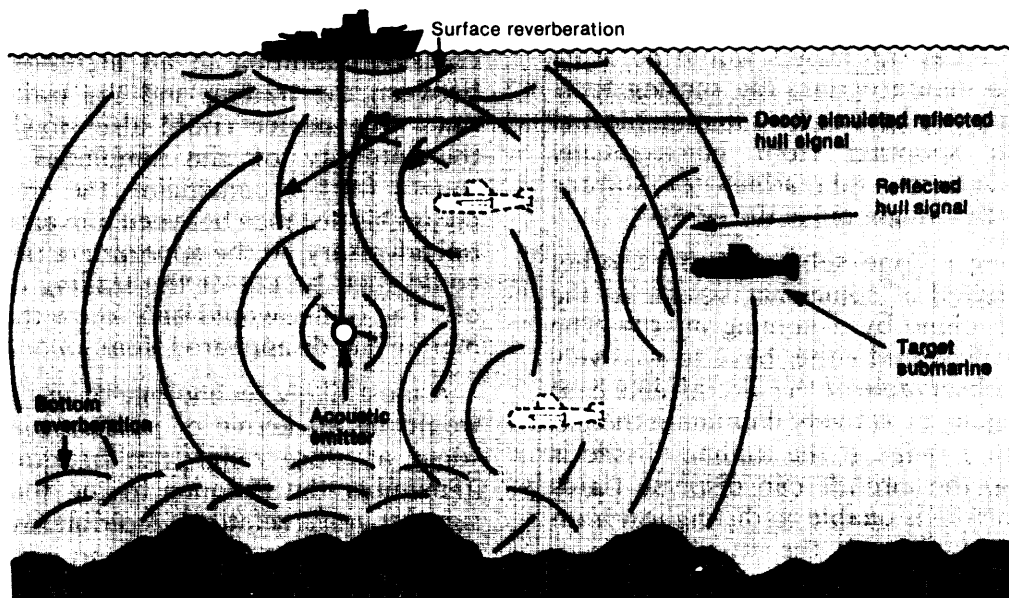
Figures 79 and 80 show another means of making it difficult to establish trail against a submarine using either active or passive sonar. The submarine (or accompanying tugboats from the port) could deploy small torpedo-like devices (similar, in principle, to the radar confusing Quails deployed by B-52s). These devices could be equipped with small tape recorders which simulate the sound of a submarine. Electrical coils could simulate magnetic and other signatures and a transponder mounted on the device could simulate the reflection of sound from the hull of a submarine. If the need arose, devices like these could not only be carried on submarines to aid in breaking trails, but they could be deployed in large numbers each time a submarine attempted egress from port. Devices deployed from the port could be preprogrammed to behave like submarines and could regularly be recovered after each egress operation. Simple,

inexpensive, and recoverable devices could be constructed using either battery or fuel cell technology to simulate submarines egressing from port. The fuel cell device could be programmed to behave like a submarine using an inexpensive microprocessor and would have great endurance. The device could be used to deceive trailers for days, if an operational need for such a capability arose. At some pre-programmed point it could turn around and come back to port for recovery.

Still another possible device that could prove useful against a trailer using active sonar would be a device similar to the German pillenwerfer. The pillenwerfer was a device used by German U-boats during World War II. The U-boats could eject this device during the course of an engagement and create a dense underwater cloud of bubbles. Since sound would be intensely reflected by the pillenwerfer bubble screen, active sonars could mistake the cloud for a submarine or could not observe the submarine maneuvering behind the screen to escape.

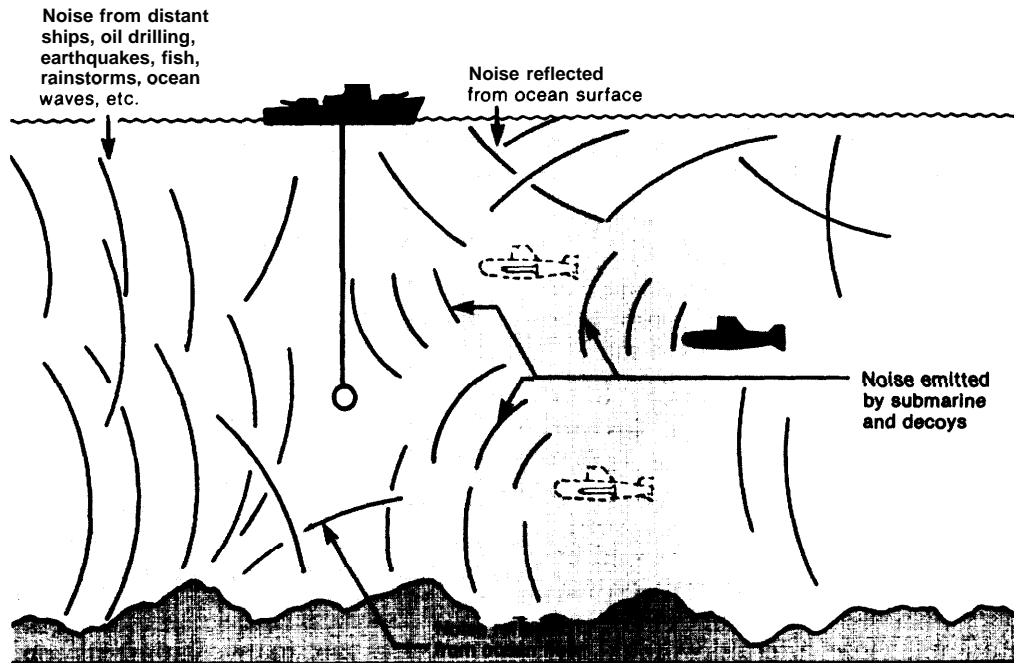
Attempting to establish trail on a submarine egressing from a home port requires not only

**Figure 79.—Active Acoustic Search for a Submarine That Has Dispensed Decoys Which Simulate a Reflected Sonar Signal From a Submarine Hull**



SOURCE: Office of Technology Assessment.

**Figure 80.—Passive Acoustic Search for Submarine That Has Dispensed Decoys Which Simulate the Sound of a Submarine**



SOURCE: Office of Technology Assessment

"spoof proof" sensing devices with sufficient range and reliability for "a trailing operation, but the technology must be difficult to jam. Jamming, while not as elegant as the method of decoys, is at least as effective a means of "delousing" submarines as they egress from port. This could be accomplished with small surface ships or preemplaced sound projectors. If the trailers are using devices like magnetic anomaly detectors, relatively modest-sized coil devices capable of distorting the local magnetic field could be emplaced in the egress region or towed by small ships. These would, in effect, be magnetic jammers.

Still another tactic available for port egress operations might be to use the 12-mile limit to force the adversary to spread himself thin. The submarines could proceed up or down the coast well within territorial waters before proceeding into the open ocean. Since the submarine would be in noisy shallow coastal waters, it would be undetectable from outside the territorial limit. The adversary would vir-

tually have to commit thousands of ships to attempt to establish trail on port egress.

Finally, the logistics of establishing a picket in order to pick up egressing submarines should not be neglected. Assets stationed outside a port in order to try and pick up egressing submarines would have had to transit from home ports. This would mean that each ship would have to spend a period of time covering the port access looking for egressing submarines, a period of time transiting back to home ports for resupply and repair, and a period of time transiting back again to cover the port. Enough ships and/or submarines would have to be committed at all times to the port watch so that all the entrances, exits and coastline which submarines could use for egress operations from the port would be continuously covered. There must also be enough excess ships or submarines on station so that all suspicious contacts can be prosecuted until they are determined to be false targets.

It should be clear that egress from port has such a rich diversity of countermeasures and technologies that it can effectively be considered a nonexistent threat to any well-run submarine force.

### Establishment of Trail Using Large Area Open Ocean Search

Since egress from port has such a variety of operational countermeasures and technologies that favor the egressing submarine, an adversary may instead choose to combine a large area search with trailing vessels at sea.

Again, for purposes of illustration, it is assumed that 300 to 600 long-range aircraft equipped with radars that allow for a 14,000 nmi<sup>2</sup> per hour search rate transit from Cuba to a 3-million-nmi<sup>2</sup> deployment area in the Northwest Atlantic. This fleet of aircraft would be large enough to maintain 100 aircraft on station, 24 hours per day. Between transit and search operations, these aircraft would consume more than 1.5 million gal of aviation fuel per day. As postulated earlier, such a search might produce a radar contact with 1 of the 50 assumed submarines on the average of once an hour. This contact would occur when the submarine was snorkeling so the submarine would have detected the radar signal and could be presumed to recognize it had been sighted.

If the Soviets have, in addition, 1,000 ships evenly distributed over the 3-million-nmi<sup>2</sup> operating area, one ship will on the average be able to patrol a 3,000-nmi<sup>2</sup> area of approximately 30-nmi radius. Assuming the ship is, on the average, capable of arriving at the area of contact within 1 1/2 to 2 hours and the submarine has moved in a random direction at 10 knots after being detected, the ship will have to search an area of 700 to 1,200 nmi<sup>2</sup> by the time it arrives in the vicinity of the aircraft radar contact. If the ship has sonar device with a 2- or 3-mile range and can search at 10 knots, it will be able to search about 40 to 60 nmi<sup>2</sup> within the first hour of arrival at the location where the submarine was first sighted. If the submarine is not found within the first hour of search, it will have traveled another 10 nmi

from the point of sighting and would be somewhere within an area of 2000 to 3,000 nmi<sup>2</sup>.

The probability of the ship picking up the submarine would be of order 0.03 to 0.08 and would vary dramatically with how fast the ships arrive at the point of aircraft sighting. Assuming that the probability of the ship establishing trail is 0.08, then on the average, 2 of the 50 submarines would be picked up on trail each day of operation.

If the submarine were equipped with 10 decoys, it could then attempt to break trail in the following manner. If trail is established, a single decoy could be released by the submarine, giving the trailer a one in two chance of choosing the correct target. If the correct target is chosen, another decoy could be released. Thus, by the time the submarine had released its tenth decoy, the probability that trail is maintained would be about one in a thousand ( $2^{10} = 1,024$ ).

There are many variations on the open ocean search followed by trailing. These variations include the use of helicopters operating from the on-station search ships and the use of multiple ships converging on sighting locations. The assets that must be committed by an adversary, under optimistic assumptions of good weather and capable reliable sensors, is enormous relative to countermeasures. In the above case, the 50 submarines equipped with 500 decoys are able to remain untraced by an adversary who has committed a fleet of 300 to 600 long-range surveillance aircraft, 1,000 surface ships, and sensors that surpass the performance capabilities of what is likely to be achievable.

As is indicated throughout the discussion on vulnerability, opportunities for obtaining information on the location of snorkeling submarines are far greater because of the increased noise output associated with snorkeling and the fact that a snorkel mast is exposed above the ocean's surface. Detailed analysis indicates that long-range passive detection of modern snorkeling submarines would not be a threat to the survivability of the force. Analysis indicates that nonacoustic search techniques

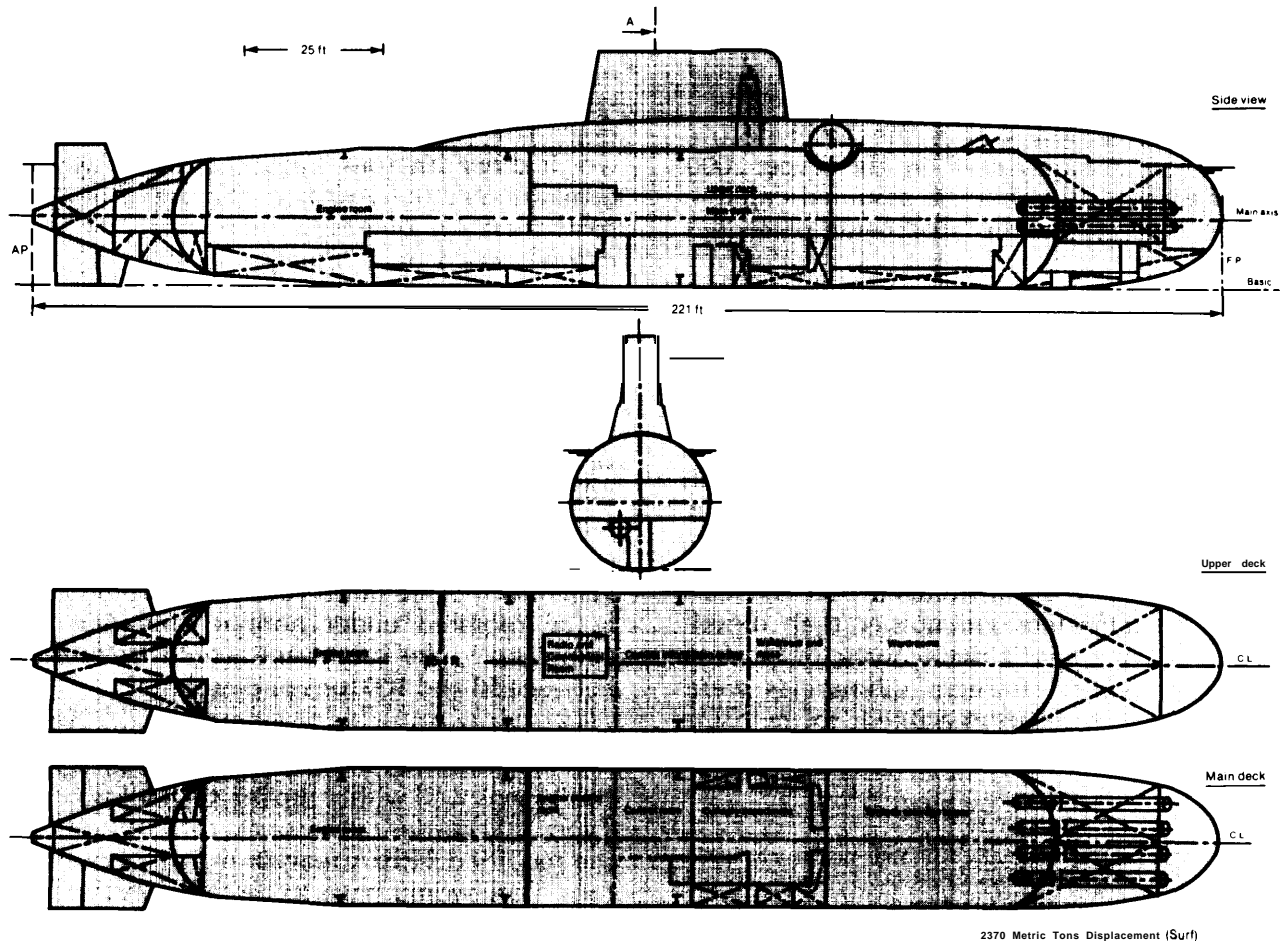
that might be able to detect snorkels will also not seriously affect the survivability of a fleet of diesel-electric ballistic missile submarines deployed within 1,000 to 1,500 nmi from the continental United States and Alaska.

Nevertheless, as remote sensing improves and satellite surveillance becomes more complete, it is possible that concern about the need to snorkel could arise. It is therefore of interest to describe some features of modern diesel-electric propulsion systems and compare them to another proven propulsion technology — nuclear propulsion.

### Diesel-Electric Propulsion Technology

The diesel-electric propulsion system in the German-type 2000 powerplant is an example of proven capabilities in modern nonnuclear submarines (see fig. 81). The submarine is designed to snorkel using four 1,400 RPM high-speed diesel-driven generators simultaneously. When configured as an attack boat, it will snorkel less than 90 minutes out of 24 hours (assuming it snorkels with a 6-knot speed of advance and patrols on batteries at 5 knots). If the submarine were configured as a strategic weapon submarine instead, additional power would be

Figure 81.—German Type 2000 Submarine



SOURCE: Office of Technology Assessment



consumed due to increased hydrodynamic drag on the missile fairings and added load due to the strategic weapon system and the missiles. The snorkeling period with these additional loads would be about 2 1/2 hours per day (i.e., the submarine would snorkel about 10 percent of the time). The submarine carries 960 batteries which are energy-managed by a microprocessor. The propulsion motor has a maximum output of 7,500 kW and is double mass isolated from the hull for silencing. The motor is air coupled to the shaft (for silencing) and the shaft drives a seven-blade skewback propeller. When configured as an attack submarine, this boat has a top speed close to 25 knots (which can be maintained for about 1 hour).

When operating on batteries, any modern diesel-electric submarine will, for all practical purposes, be close to acoustically undetectable by passive means. Thus, the diesel-electric technology demonstrated in the Type 2000 would easily fall within the assumed capabilities of the vulnerability discussion presented earlier.

### Nuclear Electric Propulsion

Small submarines that use nuclear propulsion might have survivability superior to those powered by diesel-electric systems. \* However, this would depend on the nature of any unforeseen future threat that might emerge and is therefore difficult to analyze.

It is generally acknowledged that nuclear-powered submarines are noisier than diesel-electric submarines. If the acoustic outputs of nuclear-propelled strategic submarines were large enough to result in a threat to their survivability (and they are not), proven technol-

ogy exists that would permit them to be equally quiet.

Since the coastally deployed strategic submarine has modest power requirements relative to those needed by longer range faster and more versatile submarines, it is possible to use an inexpensive self-regulating TRIG A-type nuclear reactor as a power source alternative to diesel-electric propulsion. The power system would employ fully developed reactor technology used in conjunction with standard hardware and electronic components. Because of the self-regulating features of this type of reactor (and, in fact, any small low enrichment reactor), the safety and control systems on the reactor would be very simple. The reactor would be natural circulation and conversion to electricity could be accomplished using thermoelectric modules (about 4 to 6 percent conversion efficiency is within proven technology). The reactor, with its shielding, would weigh about 100 tons. Since the reactor would generate electricity without the use of moving parts (neither generators or pumps), the submarine would be as quiet as an electric-powered submarine and would never have to snorkel.

The submarine could carry 550 tons of batteries as does the Type 2000 submarine since it would need extra propulsion power on occasion. It would therefore have high-speed capability similar to the Type 2000 until the batteries were drawn down. Quick recharging would be done with the aid of diesel-driven generators. Since quick recharging would rarely be required under normal operating circumstances, the submarine would carry only between 50 and 100 tons of diesel fuel.

The weight budget of the Type 2000 submarine indicates that a small submarine design of this type is well within proven technology. The Type 2000 carries close to 300 tons of fuel and the modified TRIGA reactor weighs about 100 tons. Care would have to be taken in the submarine design to account for differences in weight distribution dictated by a single large component like a reactor.

A specific system design and the fabrication of a prototype would be required before a

---

\*It is hard to say that a coastally deployed, small strategic submarine would be more or less survivable if it were nuclear powered since its survivability would not depend on an ability to maintain high speeds for extended periods of time, as might be the case with attack submarines. In addition, since the coastally deployed submarines would always be relatively near the continental United States, they would not have long transits to and from patrol areas. In any case, the survivability of either diesel-electric and the nuclear-powered units would be so high that the choice of propulsion system need not be of serious concern.

reactor unit could be brought into service. If reactors were then produced at a rate of at least six units per year, it would cost less than \$20 million (1981 dollars) per unit. This figure would add only a marginal cost to the submarine.

If a decision were to be made to deploy MX missiles on small submarines, such a propulsion system would clearly be a competitor with diesel-electric propulsion, both in terms of survivability and cost. This deployment would have to be considered by any design group tasked with the problem of designing an MX-carrying system of small submarines.

### Concluding Remarks on the Vulnerability of Submarines

Antisubmarine warfare techniques and methods is an area of high sensitivity due to

concerns about security. For this reason, the numbers used in this section in conjunction with specific search technologies should in no way be construed as indicating the state of the art with regard to the sensing technologies discussed. What this discussion has sought to do is provide the reader with a sense of the richness, diversity, and complexity that accompanies both submarine technologies and operations. It should also be noted that all technologies that could in principle or in practice be used as a means to find submarines have not been discussed. However, the conclusions that can be drawn about the survivability of strategic submarines from the present discussion in fact vastly overstate the vulnerability of these systems.

## FACTORS AFFECTING THE ACCURACY OF LAND- AND SEA-BASED MISSILES

In this section, some of the factors that play a role in determining the accuracy of land- and sea-based ballistic missiles are presented in order to establish a context for discussion in the sections that follow.

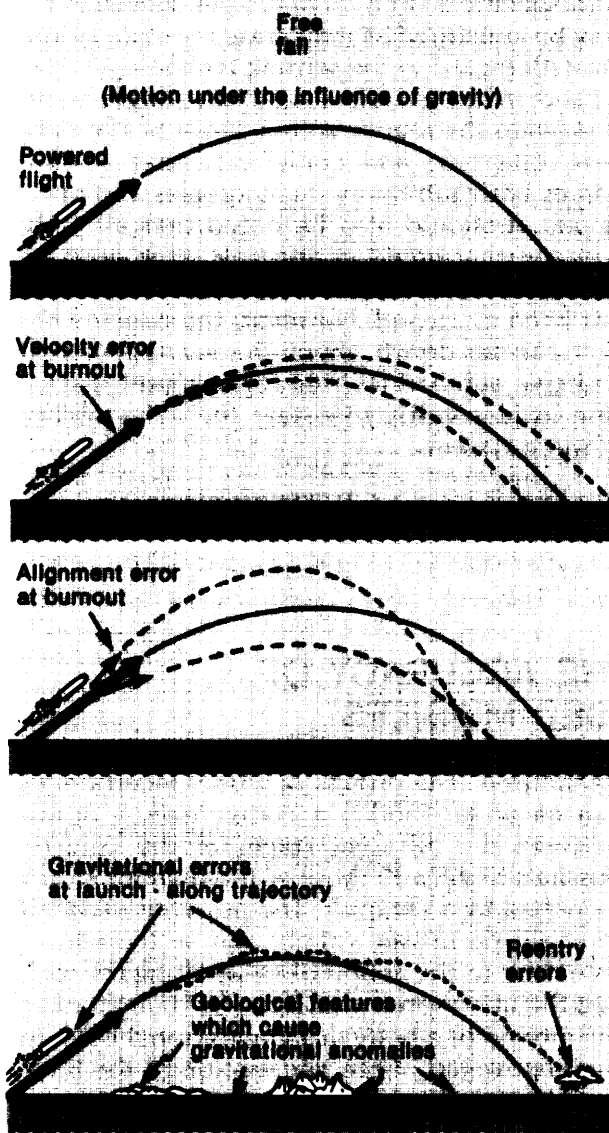
A ballistic missile is a device that is accelerated to a velocity sufficient to reach a target or set of targets without further propulsion. Intercontinental range ballistic missiles (missiles with a range of order 6,000 miles) generally undergo powered flight for a period of 5 to 10 minutes. Once powered flight is complete, the missile's upper stage and reentry vehicles float toward a target, or a set of targets, under the influence of gravity in the near vacuum of space. In the final portion of the flight, the reentry vehicles enter the upper atmosphere and are subjected to very strong aerodynamic forces before finally arriving at targets.

During the initial stages of powered flight, guidance errors can be introduced by uncertainties in the missile's velocity, position, and

orientation. The effects of these uncertainties can be understood if a comparison is drawn between the different stages of the ballistic missile's flight with those of the flight of a rock launched by a catapult. The powered phase of the ballistic missile's flight can be thought of as similar to the action of catapulting the rock and the unpowered phase can be thought of as the motion of a body in a gravitational field. In the unpowered phase, the motion of the body is entirely determined by the force of gravity.

Since the phase of powered flight is similar to that of the catapulting of a rock, if the missile is almost on course after the engines have burned out, but the magnitude of its velocity is slightly in error, it will fall short or long of the target (see fig. 82). If the missile velocity is correct but the missile is slightly misaligned from its intended direction, it will also miss the target. In addition, even if the missile is properly aligned and has the correct speed, if its launch point is moved with respect to the target, the missile will again miss its target.

Figure 82.— Factors Affecting the Accuracy of a Ballistic Missile



SOURCE: Office of Technology Assessment

The effects of uncertainties in the gravitational field also influence the missile's accuracy in the early stages of powered flight. When the missile is initially launched, the forces that determine the motion of the missile are due to the thrust of the rocket's engines and the gravitational field of the Earth (aero-

dynamic forces are neglected here for simplicity). If the gravitational field is not known in detail, the missile will end up, after launch, with a slightly different direction and velocity than originally intended. Since this change occurs early in the missile's flight, a slight misalignment in direction, or uncertainty in velocity, accumulates into a much larger target miss as the missile floats for great distances along its trajectory. As will be explained later in this section, these velocity and direction errors can be introduced due to lack of knowledge of the Earth's gravitational field, as well as due to imperfections in different elements of the missile system. If unaccounted for, these errors can accumulate into significant miss distances at the target.

After the missile's engines are turned off, its motion is determined by the gravitational field of the Earth. If the gravitational field is different from that which is expected, the reentry vehicle will not follow the trajectory that has been planned for it. For this reason, the missile guidance system must have data on the nature of variations of the Earth's gravitational field along the trajectory to the target.

Still later in the missile's flight, the reentry vehicle enters the upper atmosphere and begins to decelerate violently (this process usually begins at about 100,000 ft for a warhead flown at intercontinental ranges). In this stage of flight, wind and rain can have an effect on the reentry, as well as uneven ablation, body wobble, or misalignment. Errors that occur in guidance during this stage of ballistic missile flight are called "reentry errors."

Missile accuracy is generally defined in terms of the circle of equal probability (also called the circle error probable) or CEP. The CEP is the radius of a circle that is drawn around the target in which, on the average, half of the reentry vehicles fired at the target fall. There are two geometric contributions to the CEP. The first is called the cross range or track error. This error is a measure of the miss distance perpendicular to the direction of the missile's motion at the target. The second geometric contribution to the CEP is the down range or range error, that is the miss distance

along the direction of the missile's motion at the target.

Table 25 shows the different contributions to target miss for a missile which depends on pure inertial guidance at a range of 5,500 nmi. This table gives some indication of the importance of initial errors in position velocity, and alignment in determining the missile's CEP. Each of these error components contributes to the down range and cross range errors as the square root of the sum of the squares (see fig. 83). The CEP is then 0.59 times the sum of the down range and cross range errors.

The major factors that contribute to the accuracy performance of any inertially guided intercontinental range ballistic missile (missiles of nominal range of 6,000 nmi) can be broken into the following categories:

1. uncertainties in the initial position, velocity, and orientation of the missile at launch,
2. boost phase guidance errors due to inertial sensing errors, and inertial computational errors,
3. thrust termination errors at the end of the boost phase,
4. velocity errors imparted to reentry vehicles during deployment by bus,

5. gravity anomaly errors,
6. uncertainties in the position of targets (targeting errors), and
7. atmospheric reentry errors.

Although the magnitude and importance of each of these factors in determining missile accuracy will vary (with missile design, missile range, weather conditions over the target area, and the quality of gravitational data over the flight trajectory of the missile), all but two of these factors are in principle the same for both land- and sea-based missiles.

Factors 1 and 5 account for most of the difference in accuracy of land- and sea-based systems.

Since sea-based missiles are constantly in motion, the missile must be provided with accurate information on its position, velocity, and orientation. This necessity requires a navigation system capable of providing information to the missile before it is launched. The quality of this navigational data will affect the performance of the missile.

The quality of gravitational data near the launch points of land- and sea-based missiles may differ. If this is the case, this too will affect the accuracy performance of the missile.

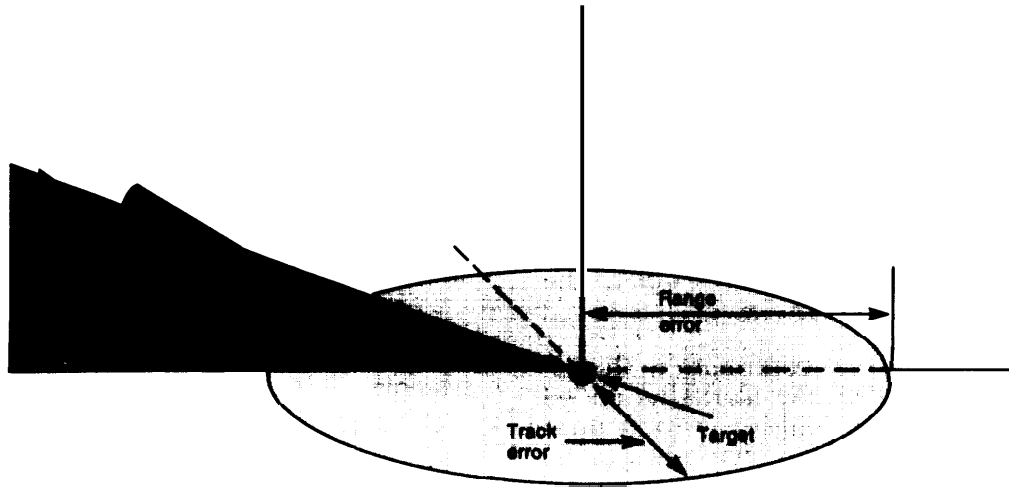
**Table 25.—Miss Sensitivities to Initial Errors for ICBM Trajectories**

Error Component		Miss Sensitivities		
		Units	Down Range	Cross Range
<b>Initial Position Error</b>	<b>Down range</b>	m/m	1	<b>0.0</b>
	<b>Cross range</b>	m/m	0.1	<b>0.7</b>
	<b>Vertical</b>	m/m	<b>5.4</b>	<b>1.3</b>
<b>Initial Velocity Error</b>	<b>Down range</b>	m/(cm/see)	<b>40</b>	<b>9</b>
	<b>Cross range</b>	m/(cm/see)	<b>2</b>	<b>10</b>
	<b>Vertical</b>	m/(cm/see)	<b>22</b>	<b>6</b>
<b>Initial Alignment</b>	<b>Level</b>	m/arcsec	<b>46</b>	<b>21</b>
	<b>Azimuth</b>	m/arcsec	<b>6</b>	<b>24</b>

\*These values apply to a 5500 nmi minimum energy trajectory CEP = .59 (Down range error + cross range error),

SOURCE: "Guidance System Application of MX Basing Alternatives" by Major G B Green/SAMSO and L N Jenks/TRW

**Figure 83.—Down Range and Cross Range Errors of a Ballistic Reentry Vehicle at a Target**



SOURCE: Office of Technology Assessment.

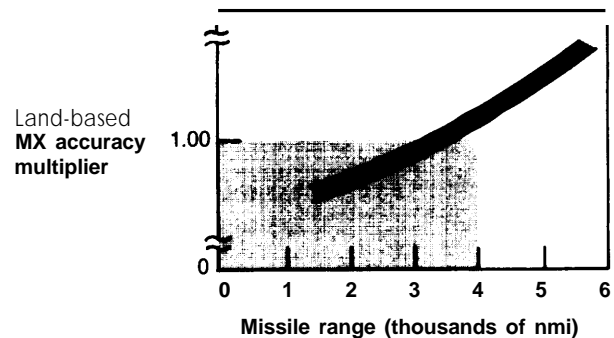
## ACCURACY OF SMALL SUBMARINE BASED MX

The object of having a missile with great accuracy is to have the ability to place warheads sufficiently close to very hard military targets so that there will be a high probability of destroying them. The ability to do this will in general depend on the nature and the quality of the guidance technology used by a missile system and the range of that missile from its targets.

The MX, as designed, is a purely inertial guided missile. In the following presentation the accuracy of a sea-based MX that uses purely inertial guidance will be discussed next, and the accuracy of a sea-based MX that uses inertial guidance in conjunction with radio beacons will be discussed last.

Figure 84 is a graph of the CEP accuracy multiplier for a sea-based MX with pure inertia I guidance. A CEP accuracy multiplier of 1.0 on the graph means that the expected CEP of the missile at that range from target will be equal to the engineering-design requirements for the land-based MX. A CEP multiplier of 1.5 means that the CEP at that range will be 1.5 times that

**Figure 84.—Accuracy of Inertially Guided Sea-Based Missile at Different Ranges From Targets**



SOURCE: U.S. Navy.

of the design requirements of the land-based MX, and so on. At present, it appears likely that the land-based MX will have a smaller CEP than that set for its design requirements, so a CEP multiplier of 1.0 does not necessarily mean accuracy equal to a land-based MX. The graph assumes that the submarine's position is known within a few meters and that it would use a velocity measuring sonar to measure its

velocity. None of the above assumptions present any operational problems for the submarine fleet (for reasons that will be discussed later) and so this graph can be considered a good operational representation of achievable accuracies at different ranges from targets.

In order to illustrate the significance of range from target effects for the small submarine-based MX missile, table 26 lists a number of cities in the Soviet Union in regions that also may have targets of military interest. The number in the upper part of each of the boxes in the table is the range from one of the three submarine deployment areas to targets within the regions surrounding these cities. In the lower part of each box the expected hard target kill capability of a sea-based MX is compared to that of the hard target kill requirements for the land-based missile. It should be kept in mind that the accuracy requirements set for the land-based MX result in very large single shot kill probabilities against targets of great hardness. In fact, the single shot kill probabilities used to compile table 26 are sufficiently large that differences described as "slightly better," "comparable," and "slightly worse" may not be of military significance (see Classified Annex for numerical details).

If targets in the region around Novosibirsk were to be attacked, warheads would have to

travel roughly 3,700 nmi to reach their targets. The graph in figure 83 indicates that for that range, warheads fired from the Gulf of Alaska could have an expected accuracy at the target slightly better than the design requirements set for the land-based MX. Missiles fired from the Northeast Pacific deployment area would have slightly worse accuracy than that of the land-based design requirements and missiles fired from the Northwest Atlantic deployment area would have still worse accuracy than those from the Pacific area.

The significance of a slightly improved or degraded hard target kill capability becomes still less significant for hard targets which merit attacks with more than one warhead. If, for instance, a single warhead fired from one submarine operational area had a probability of 0.95 of destroying a particular hard target and a second warhead fired from a different submarine operational area had a 0.85 kill probability against the same target, a 2-on-1 attack would still have a greater than 0.99 probability of destroying the target being attacked. This means that cross targeting could be performed from different operational areas with considerable flexibility.

This point is applicable even for targets in areas that are extremely far from all of the submarine operating areas. Even though these tar-

**Table 26.—Comparison of Hard Target Kill Capabilities of Sea-Based MX” With Design Requirements of the Land-Based MX**

Range to target from launch area	Relative hard target kill capability		
	Gulf of Alaska	Northwest Atlantic	Northeast Pacific
Moscow . . . . .	4,200 Comparable	3,900 Slightly better	4,500 Comparable
Semipalatinsk . . . . .	4,000 Slightly better	5,200 Slightly worse	4,700 Slightly worse
Vladivostok . . . . .	3,000 Slightly better	5,800 Worse	3,900 Slightly better
Novosibirsk . . . . .	3,700 Slightly better	4,800 Slightly worse	4,400 Comparable
Minsk . . . . .	4,100 Slightly better	3,600 Slightly better	4,600 Comparable
Irkutsk . . . . .	3,400 Slightly better	5,200 Slightly worse	4,200 Slightly better
Tashkent . . . . .	4,600 Comparable	5,600 Worse	5,500 Worse
Tyuratam . . . . .	4,500 Comparable	4,900 Worse	5,200 Worse

a Numerical values available in the Classified Annex

SOURCE: Office of Technology Assessment

gets are at very great distances from all the submarine operating areas, and accuracy degrades with distance from target, such targets will still be subject to successful attacks from sea-based missiles in the late 1980's and early 1990's.

The most extreme test of the system capability shown on table 26 are targets in the region surrounding Tashkent, in the extreme southern region of the Soviet Union (Tashkent is about 200 miles from the Soviet Union's border with Afghanistan). Single warheads fired from the Gulf of Alaska would have to travel about 4,600 nmi to targets in that region and would have single shot kill probabilities comparable to the design requirements set for the land-based MX. Missiles fired from the other two operating areas would have to traverse much greater distances (about 5,600 and 5,500 nmi). The probability of destroying hard targets in this region with a 2-on-1 attack using missiles from *any* combination of submarine operating areas would differ by only a few percent. Thus, even in the extreme case of very distant hard targets, 2-on-1 targeting would result in an almost indistinguishable difference in capability to destroy very hard targets of importance.

If the targets were to be made still harder in an attempt to increase their survivability against sea-based warheads with the yield accuracy combinations used to construct table 26, it might be possible to gain several percent more survivability against 2-on-1 attacks. The small gains introduced by such a program, would be enormously costly and could be wiped out by additional possible improvements in accuracy.

Table 26 assumes that all missiles fired against targets work, that is, it is compiled under the assumption of 100-percent missile reliability. If missile reliability is not better than the single shot kill probabilities, missile reliability will be more important a determinant of the hard target kill capability than accuracy. In the opinion of OTA, single shot kill probabilities from sea-based missiles could be so high by the 1990's, that missile reliability,

not accuracy, will be the dominant factor determining hard target kill capabilities.

The guidance technology assumed in table 26 assumes minimal changes to the MX missile guidance system. The MX computation techniques used by the guidance system would have to be optimized for sea basing rather than land basing and high frequency gravitational data of the quality expected to be available in the late 1980's or early 1990's would have to be known within a 200-nmi radius of the launch point. In addition, the data summarized in table 26 assumes that the submarine would know its position to several meters and would use a velocity measuring sonar to update its velocity. Analysis performed by OTA indicates that the use of velocity measuring sonars does not introduce either operational or vulnerability problems for the MX-carrying submarines. However, if the GPS were destroyed, the satellites would not be available for position update immediately prior to missile launch. If the submarine did not take satellite position update several hours prior to launch, knowledge of its position would be sufficiently degraded that the accuracy curve presented in figure 84 could not be achieved against distant targets. This potential problem is, however, easily solved by proper force management.

If antisatellite boosters or launches were detected from American early warning sensors, the submarines could be informed over VLF channels that an attack on the satellite navigation system could be in progress. In response to this, the submarines would immediately proceed to update their navigational systems in the hours before the intercepts. While performing the satellite fix the submarines could simultaneously issue a "ready" signal to NCA via the Deep Space Millimeter Wave Satellite System. Since the submarines would be under orders to avoid all shipping at all times, it would be extremely unlikely that a submarine could not take a fix within the time period before loss of the satellites.

In the unlikely event that one or two submarines were unable to take a fix before hostil-

ities began, they could immediately proceed to the nearest acoustic transponder field. This would take the submarine between 2 to 3 hours. If a launch order were given during this period of time, submarines with sufficiently accurate guidance data could be in a position to launch without risk to the ship. Any submarine that had not reported a "ready" signal could immediately have its target package reassigned to one of the other submarines on sta-

tion. This could be done using VLF channels if it only required reassignment of a prepackaged option or it could require the high data rate satellite link if ad hoc targets which are not listed on the National Target List are to be attacked. This force management procedure could therefore guarantee that the submarine force could strike targets on short notice with very high accuracy.

## ACCURACY OF STAR-TRACKER-AIDED INERTIALLY GUIDED MX

Heretofore only the accuracy that is likely to be attainable using purely inertial measurements as a means of guiding the missile is considered. We now consider the additional accuracy that could be attainable if the inertial guidance system is updated using some form of external reference. First the use of star trackers is discussed, and then the use of radio beacons, as means of updating the missile's inertial guidance system in order to obtain higher accuracy at greater ranges.

It is possible to mount a device on the missile guidance platform that will allow it to take a fix on a star after it leaves the atmosphere. This technique is currently being used on the new TRIDENT I missile and would be a more significant modification to the MX missile guidance system than that assumed in constructing table 26. Such a modification could delay the deployment of the missile by a year and cost several hundred million dollars. However, as will be discussed in the section on schedule, the submarines design and construction schedule should pace the missile development. Delays in the research and development of the missile would therefore not be likely to affect the date that the first missiles could be put to sea.

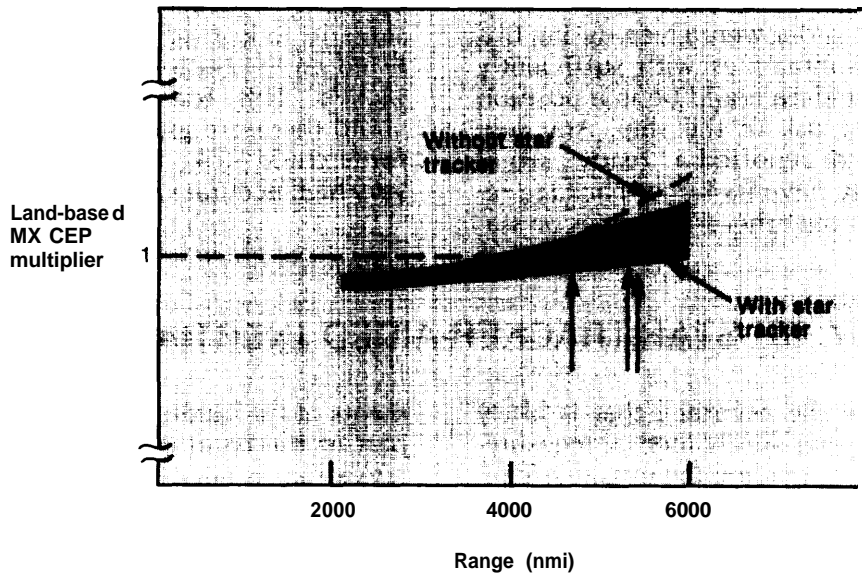
The broad band in figure 85 shows a conservative estimate of the band of possible accuracies versus range for an MX-like missile which has been fitted with a star tracker. As in figure 84 the accuracy multiplier is defined with respect to the engineering design require-

ments of the land-based MX missile. The upper part of the band is the accuracy versus range curve that is very likely to be achieved in the late 1980's or early 1990's. The three vertical arrows define the distances to Tashkent from the Gulf of Alaska, Northeast Pacific, and Northwest Atlantic deployment areas. As can be seen from the graph, it is very likely that all targets in the Soviet Union could be attacked in the late 1980's or early 1990's from all submarine operating areas with accuracies marginally better or worse than that of the engineering design requirements of the land-based MX. The lower part of the band represents a conservative estimate of what is possible in the late 1980's or early 1990's if the advanced MX inertial measurement unit is used in conjunction with a star tracker. If this level of performance is reached, all targets could be covered from all deployment areas with CEPs at least as good as the engineering design requirements of the land-based MX.

For purposes of reference to the earlier discussion, the dashed line plotted in figure 85 shows the accuracy multiplier versus range for an MX missile guided without the aid of a star tracker. The hard target kill probabilities used to construct table 26 and discussed earlier in this section are derived from this curve. Since the addition of a star tracker to the inertial guidance package helps reduce certain range-dependent guidance errors during the early stages of flight, the star tracker aided inertially guided missile displays a weaker degradation



**Figure 85.—Accuracy of Star-Tracker-Enhanced Sea-Based Missile as a Function of Range From Target**



SOURCE: U.S. Navy

of accuracy with range relative to that of the purely inertial guided MX.

It should be noted that the star tracker accuracy versus range curve shown in figure 85 is derived on the basis of assumptions about the availability and capability of certain technologies relevant to guidance, quality of navigational data at the time of launch, and knowledge of geophysical data around the launch point and along the missiles trajectory. The assumptions are as follows:

1. An Improved Submarine Inertial Navigation System (SINS) and/or accurate initial

position and velocity data at time of launch. Accurate data at time of launch could be obtained with the aid of: acoustic transponders, velocity measuring sonars, and the Global Positioning System.

2. Introduction of gravity gradiometers on submarines and/or quality high frequency gravity data within 200 nmi of the launch point. It is expected that these technologies and data will be available in the period of the late 1980's to early 1990's.

## DEGRADATION IN ACCURACY AFTER A SUBMARINE NAVIGATION FIX

Because a star tracker enhanced, inertial guided missile is able to obtain navigational information by sighting on stars during its flight, its accuracy at range is not as sensitive to navigational uncertainties introduced by the continuous motion of its launch platform, as is the case with a purely inertial guided missile.

It is expected that submarine inertial navigation systems will be considerably improved even relative to their currently impressive capabilities. Improvements in inertial guidance technologies, gravitationally mapping and the use of star trackers on missiles is expected to dramatically lengthen the time needed be-

tween navigational updates of the submarine inertial guidance system. In the 1990's, navigational updates would not be required for days

or even weeks in order to maintain sufficient capability to attack very hard targets from sea.

## INERTIAL GUIDANCE AIDED BY RADIO UPDATE

The two sets of accuracy data so far discussed are based on improvements in inertial guidance technologies that are used in missiles and in submarines, and on improved geodetic and gravitational data.

Another set of guidance technologies that could be used to obtain high accuracy with sea-based missiles without precise navigational data at launch and extensive gravitational mapping is a system based on inertial guidance aided by updates from radio navigation aids.

Radio updates could be taken with the aid of the GPS. They could also be taken with the aid of a system of ground radio beacons CBS (also referred to as an Inverted GPS), that could be emplaced on the continental United States. In the event that the GPS is attacked using antisatellite weapons, the GBS could provide backup radio navigation aids to the missiles in flight. Unlike the GPS, the CBS would only operate during a crisis, and could be made costly to attack by constructing many radio beacons and decoys.

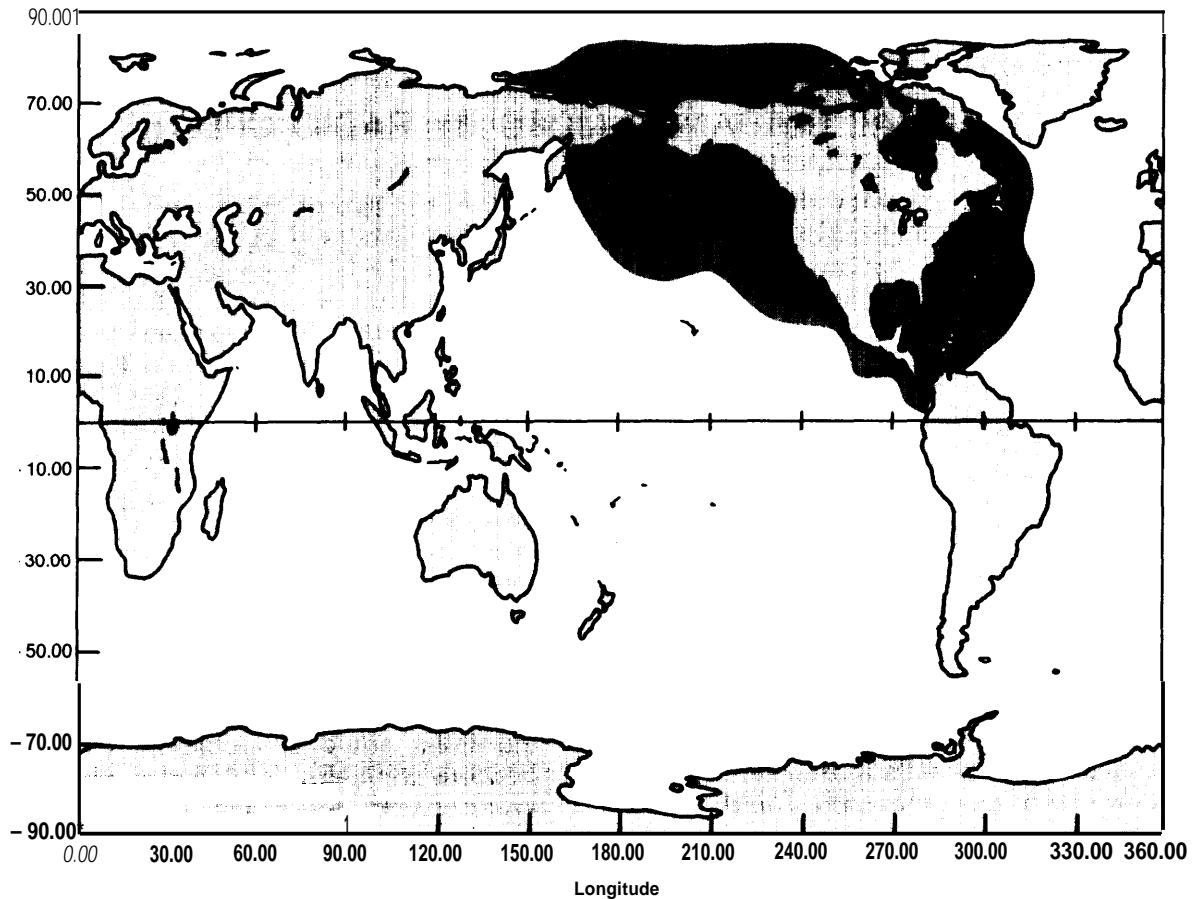
The sea-launched missile could radio update its inertial guidance system in three different ways. The missile could take a navigational fix using GPS to update its inertial guidance system before it deploys its reentry vehicles from the missile's post boost vehicle (i. e., the missile's bus). In the event of outage of the GPS, the navigational fix could instead be taken using the ground beacons. If the GPS were destroyed and the ground beacons were used as a backup system, it would be necessary to take a radio fix through the ionosphere. This radio fix might be disrupted if there were nuclear detonations occurring in the ionosphere. In order to avoid disruptions of this type, a radio fix could be taken before the missile reaches the bottom of the ionosphere, perhaps at an altitude of about 50 miles.

The first two of these methods should provide MX accuracy at all ranges from Soviet targets. If the GPS were used, missiles could be launched from anywhere in the submarine deployment area. If the ground beacons were used, system accuracy would be degraded if the submarines were not within 700 to 900 nmi of the continental United States. This degradation would occur due to errors introduced into the navigational update by poor line of sight geometry on the ground beacons. Figure 86 shows the areas of ocean from which a CEP multiplier of one could be achieved if ground beacons were emplaced on the continental United States, Alaska, Hawaii, and on the Aleutian Islands. Figure 87 shows the additional Pacific area from which the same CEP multiplier could be achieved if the ground beacons were also emplaced on the islands of Wake, Guam, Kwajalein, Palau, and Tafuna, Samoa.

If the ground beacons were used to update the missile guidance system before the missile reached the ionosphere (this update could be necessary if the GPS system had been destroyed and the ionosphere was disturbed by the detonation of nuclear weapons) the submarines would have to be within 400 to 500 miles of the continental coast if a radio update is to be possible before the lower ionosphere is reached. Using this method of update, a CEP multiplier of 1.0 to 1.5 that of land-based MX might be achievable. Unfortunately, calculations on this type of update have not been performed in detail and a more accurate assessment of the capability of this type of update is not available.

In summary, a sea-based MX could be guided using purely inertial measurement technologies or with inertial measurement technologies updated by sighting on stars or radio beacons. The star trackers offer a great

**Figure 86.—Ocean Areas That Provide Adequate Line-of-Sight View of Ground Beacons on Continental U. S., Aleutian Islands, Alaska and Hawaii**



SOURCE: Office of Technology Assessment.

advantage in that they are a self contained element of the missile and have been demonstrated to be highly reliable. Radio beacons on satellites, and on land, also can be used for updating the missile's inertial guidance system.

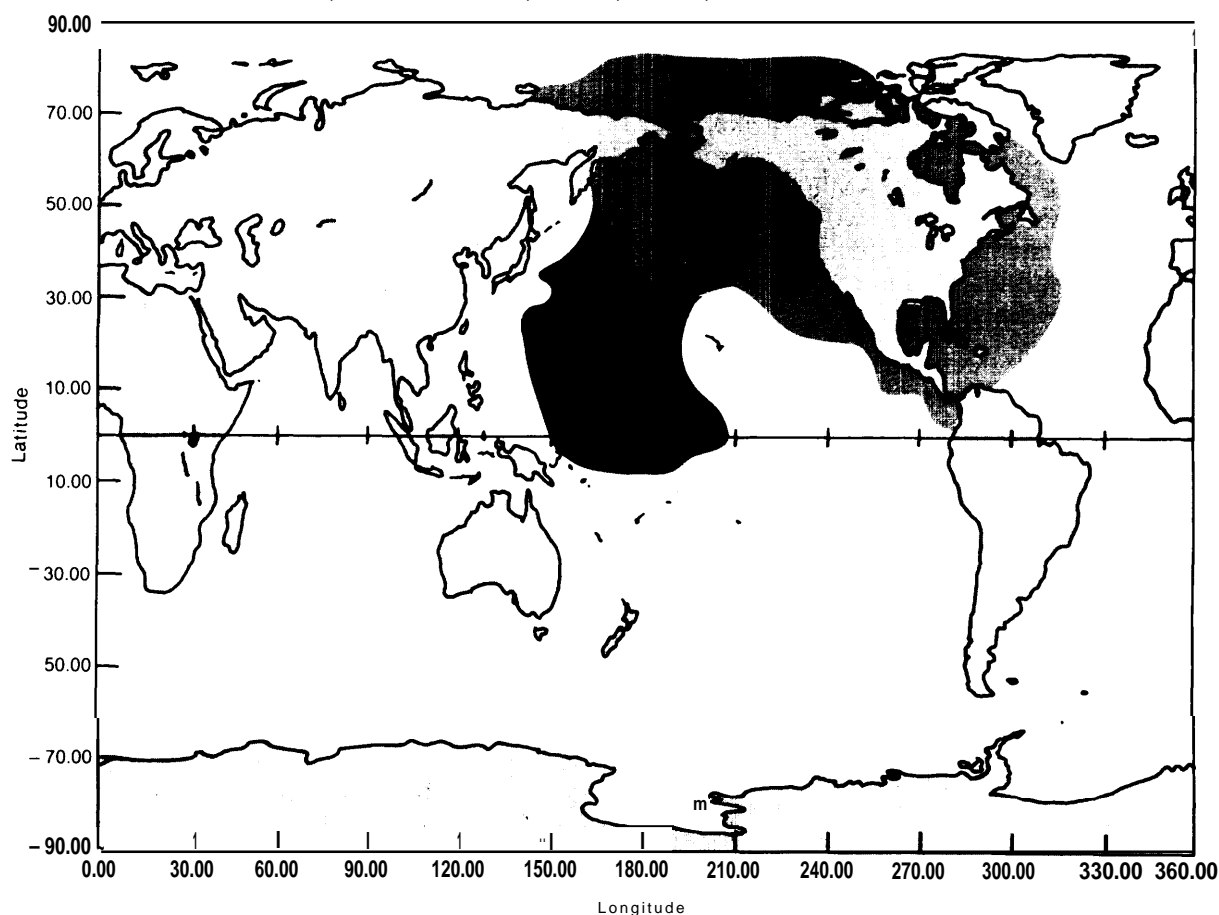
By deploying a large enough system of ground beacons and decoys as a backup to the satellite beacons, the risk from Soviet countermeasures could be kept small.

## TIME ON TARGET CONTROL

If the submarine system is to attack hard targets with more than one warhead, there is a need to control the time at which warheads arrive at targets with a high degree of accuracy. This control is needed so that the detonation of the first warhead will not interfere with the arrival the second warhead.

Since the small submarine would carry missiles in external capsules that would be launched at different depths under different operational conditions, the exact time at which a missile flew out of the capsule could possibly effect the arrival of warheads at targets. In practice, this problem could be

Figure 87.—Ocean Areas That Provide Adequate Line-of-Sight View of Ground Beacons on Continental U. S., Aleutian Islands, Alaska, Hawaii, and Selected South Sea Islands



SOURCE Off Ice of Technology Assessment

solved by assigning each missile a time at which warheads are to arrive at targets. Uncertainties in launch time could then be compensated for by changing the missile's trajectory (i.e., the missile trajectory could be slightly

lofted or depressed relative to the planned trajectory). Care would have to be exercised in the design of the fire control and guidance package to assure that this could be done.

## RESPONSIVENESS OF THE SUBMARINE FORCE

The responsiveness of the submarine force is determined by the speed with which an Emergency Action Message (EAM) could be transmitted to the force and the time required for the submarines to launch their missiles. The calculation of trajectories to target sets must be performed for both land- and sea-based missiles if targets are reassigned to a missile

without warning. The time necessary for these calculations would be of order a few minutes and would not be a factor likely to delay a launch.

Therefore, the two time periods that would dominate the ability of the submarine force to respond rapidly to an EAM would be the time

period needed to receive the EAM and the time period needed to prepare the submarine for the launch of missiles. The EAM could be received in a pre-attack or transattack period within a few minutes. If the submarines were ordered to execute a preplanned strike, all data necessary for the strike would be available at the reception of the EAM and the time required to initiate the strike would be determined by the time that could be needed to bring the submarines to launch depth. This time could be several minutes.

If the ordered attack were not a preplanned option, there could be two different categories of target sets chosen, those that are stored in the guidance computer and those that are designated ad-hoc in terms of their latitude, longitude and height of burst. If the target list required a high data rate link, the VLF link would

not be appropriate. In this circumstance, a coded message would be sent over VLF for a particular submarine, or group of submarines, to come to depth and copy a new target list using the EHF satellite link. Alternatively, if the submarine force were diesel-electric powered (rather than nuclear powered), the fraction of the force that was snorkeling could receive the ad-hoc targets as well. After reception of data, which would take only a minute or two over the EHF link, the submarines could immediately prepare for launch by proceeding to launch depth, provided the strategic weapon system is configured to directly accept and validate the data from the satellite link. Launch of the missiles could take place shortly thereafter. The rapidity of response of the system could therefore be of order 10 to 15 minutes.

## ENDURANCE OF FORCE

In the event of a protracted nuclear exchange, surviving ICBMs might be required for strikes weeks or months after an initial exchange. These forces would be executed from surviving command and control centers using whatever communications channels were available.

The survival of command and control channels and the availability of communications channels during a protracted nuclear exchange is a common problem for both land- and sea-based forces. However, the endurance of the ICBMs themselves would differ with the basing mode.

The small submarine could be constructed to have an at-sea endurance of more than 90 days without support from tenders. It is assumed, based on U.S. Navy operating ex-

perience, that a normal submarine patrol would last for 60 days. This assumption means that for 30 days after an initial attack, no submarines would have to return to port. About 5 percent of the missiles at sea would be lost due to missile failures during this time. Sixty days after an initial exchange, about half the force would still be capable of remaining at sea. If the missiles were not operated in a dormant mode (so that they could be fired on a minute's notice rather than on an hour's notice) about 10 percent of the missiles could be expected to have failed at the end of 60 days. Thus, 9 weeks after an initial attack, the submarine force could deliver about 400 warheads against an enemy. By 12 weeks after an exchange, the number of operational missiles at sea would have diminished to zero.

## COST AND SCHEDULE

The small submarine basing concept is envisioned as a fleet of 51 diesel-electric submarines, each of about **3,300** tons submerged

displacement. Each submarine would be capable of carrying four externally encapsulated MX missiles. The submarines would be manned

with a crew of about 45 members and would operate within 1,000 to 1,500 nmi of three bases. One of the bases would be located on the east coast of the continental United States, another would be on the west coast, and the third would be located on the coast of Alaska.

The acquisition cost of the system of submarines, bases, navigational aids, and related operational and support equipment is estimated to be about \$32 billion (fiscal year 1980 dollars). An operating and support cost of \$7 billion is estimated for a 10-year system life-cycle. The total cost of the system is estimated to be about \$39 billion. The details of this cost estimate at the major subsystem level is presented in table 27.

The deployment schedule for a system of small submarines is shown in figure 88. This schedule would vary with the degree of commitment the nation makes to a new strategic weapon system. If the commitment is such that slippage is not allowed due to unforeseen technical setbacks, funding cuts, environmental law suits, or other actions that could require congressional action, an initial operational capability (IOC) in the middle of 1988 could occur. It could even be possible to have a lead ship by the end of 1987, but this would require a very high degree of national commitment. A more realistic estimate based on a review of military programs over the past decade would place IOC in 1990. If IOC oc-

**Table 27.—Small Submarine 10-Year Lifecycle Cost (billions of fiscal year 1980 constant dollars)**

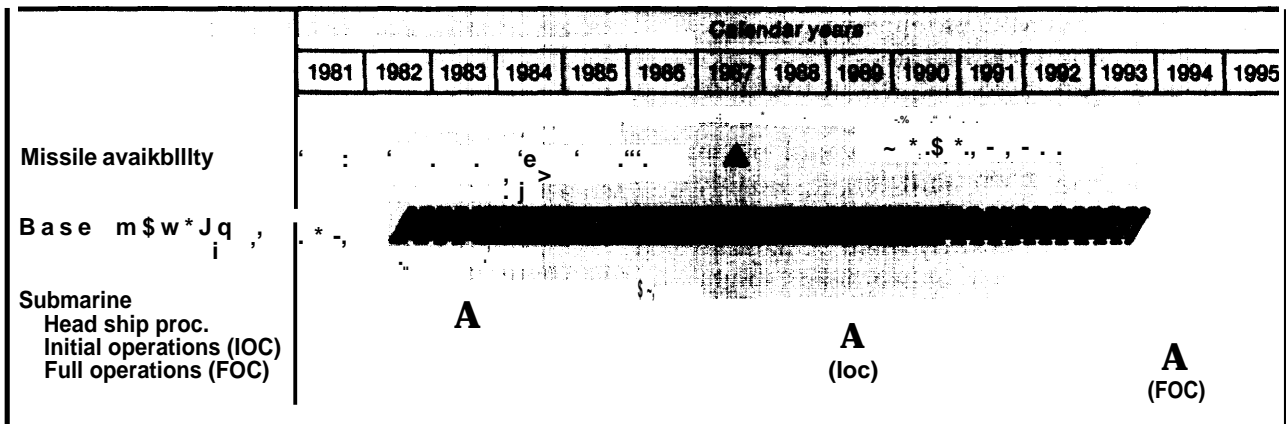
Cost element	Number	cost
<b>RDT&amp;E:</b>		
Submarine . . . . .	—	\$0.422
Missile . . . . .	—	6.056
Sws . . . . .	—	4.400
Capsule . . . . .	—	0.257
Navigational aids . . . . .	—	0.090
<b>Total RDT&amp;E . . . . .</b>		<b>\$7.225</b>
<b>Procurement:</b>		
Submarine . . . . .	51	\$ 6.682
Basing . . . . .	3	7.240
Missile . . . . .	470	5.419
Sws . . . . .	51	2.397
Capsule . . . . .	521	1.725
Navigational aids . . . . .	1,500/3,000	1.399
<b>Total procurement . . . . .</b>		<b>\$24.862</b>
<b>Total acquisition . . . . .</b>		<b>\$32.087</b>
<b>Operating and support:</b>		
IOC to FOC . . . . .		\$ 2.392
FOC to year 2000 . . . . .		4.868
<b>Total operating and support . . . . .</b>		<b>\$= 1.60</b>
<b>Total to year 2000 LCC . . . . .</b>		<b>\$39.247</b>
<b>Average acquisition \$/submarine . . . . .</b>		<b>\$0.629</b>
<b>Average LCC/submarine to year 2000 . . . . .</b>		<b>0.770</b>
<b>Average acquisition \$/deployed missile . . . . .</b>		<b>0.157</b>

SOURCE Office of Technology Assessment

curred in 1988, full operational capability (FOC) could be achieved in late 1992. If the more realistic estimate of a 1990 IOC occurs, FOC would occur in early 1994.

It should be noted that the costing of the submarine system assumes Navy procurement

**Figure 88.—Small Submarine Program Schedule**



SOURCE Office of Technology Assessment

practices for the MX missiles. In order to have 100 missiles alert at sea at all times 470 missiles are obtained. The land-based Air Force baseline procures 330 missiles. The additional missiles are obtained since it is assumed that Navy experience developing sea-based missiles would apply to the MX if it were deployed at sea. These missiles would be used in an extensive program of testing and evaluation similar to that of the Trident/Poseidon programs.

## SYSTEM SIZE

The number of submarines acquired was chosen so that 100 MX missiles would be available at sea for retaliation against the Soviet Union regardless of preemptive actions on their part. The choice of 100 surviving missiles was arrived at using the following reasoning:

The number of small submarines required for a sea-based MX system is determined by the perceived need to be able to attack a predetermined number of targets after any enemy action. The number of targets that the United States could attack after a Soviet first strike would depend on the number of missiles that survive such an attack.

It is assumed that all at sea-submarines would effectively survive an ICBM attack. This assumption is based on a review of the capabilities of antisubmarine technologies and forces. A barrage attack is not considered a significant threat for the following reasons:

The Air Force MX/MPS baseline has 200 missiles hidden among 4,600 shelters. For purposes of analysis, it is assumed that half of the land-based MX force will survive a determined Soviet attack. This assumption would mean that no more than 2,300 hard target capable warheads landed in the MX/MPS fields close enough to shelters to destroy them. A barrage attack with this number of warheads might result in the destruction of one to two submarines at sea. This does not represent a significant attrition of the submarine force.

The number of small submarines required to maintain 100 missiles at sea in an "up" status is

It should also be noted that three bases are included in the costing. Since the submarines postulated for this system would have a considerable at-sea endurance, it would be possible to deploy them from two bases instead of three. However, each of the bases would have to be larger in order to handle additional submarines. These bases would normally service nine to ten submarines instead of six to seven.

determined by the number of missiles per submarine  $M_{ps}$ , the fraction of missiles in an "up" status  $F_{mu}$  the fraction of the time a submarine is at sea during a patrol cycle  $F_{as}$  the fraction of submarines that are in overhaul or on restricted availability  $F_{or}$  and the fraction of submarines that are expected to survive an at-sea attack  $F_{\backslash\backslash}$ . The total number of small submarines  $N$  required to maintain 100 missiles is then given by:

$$N = \frac{100}{M_{ps} F_{mu} F_{as} F_{or} F_{\backslash\backslash}}$$

where

$N$  = the total number of submarines required to deliver 1,000 RVS

$M_{ps}$  = the average number of missiles per submarine

$F_{or}$  = the fraction of submarines in overhaul or restricted availability

$F_{as}$  = the fraction of time submarines are at sea during a patrol cycle

$F_{mu}$  = the fraction of missiles in an "up" status at sea

$F_{\backslash\backslash}$  = the fraction of the at sea submarines surviving after an attack

Since the missiles would be in capsules external to the hull of the submarine, they could not be serviced while the submarine is at sea. Hence, the failure of a missile at sea would put it in a down status for the remainder of the at-sea patrol.

The fraction of missiles available at sea during a patrol period of  $T$  days will be:

$$1 - \int_0^T \lambda e^{-\lambda t} dt$$

where  $\lambda$  is the mean time between failure of the missile and  $t$  is the length of time of the submarine is on patrol

Since each submarine will spend T days at sea and TIP days in port, the at sea availability of the submarine during a normal patrol cycle is:

$$F_A = \frac{T}{T + T_{IP}}$$

If a submarine spends 12 months in overhaul or in restricted availability during each 5-year operating period, then  $F_o = 0.8$ .

Table 28 presents the number of submarines that would be required to maintain 100 missiles on station for different patrol periods at sea and for different times in port for refit. It is

**Table 28.—Number of Submarines Required To Keep 100 MX Missiles Continuously on Station v. Submarine In-Port Time**

Patrol period (days)	40	50	60
Number of submarines at sea	26	26	27
<b>Total submarine force size:<sup>a</sup></b>			
12 days in port	42 (40)	41 (38)	40 (38)
15 days in port	45 (42)	43 (40)	41 (39)
18 days in port <sup>b</sup>	47 (44)	45 (42)	43 (41)
21 days in port	50 (47)	47 (44)	45 (45)
24 days in port <sup>c</sup>	52 (49)	49 (46)	46 (44)

a Total force numbers assume that 20 percent of all submarines will be in extended refit or overhaul and are therefore unavailable. Numbers in parentheses assume 15 percent of the force in overhaul or extended refit.  
 b Naval Sea Systems Command estimates minimum time in Port required for refit is 18 days.  
 c OTA assumes 25 days in port for refit and handling of missiles.  
 SOURCE: Office of Technology Assessment

assumed that 100 percent of the submarines survive preemptive enemy action and that 20 percent of the submarine force is either undergoing overhaul or is in restricted availability. The numbers in parentheses assume 15 percent of the submarines are in overhaul or restricted availability instead of 20 percent. Thus, if it proved feasible to perform refit operations in 18 days (instead of OTA'S assumed 25 days) and to have 15 percent of the submarines in overhaul and extended refit, it would be possible to maintain 100 missiles on station with a fleet of 41 submarines, rather than the 51 submarines assumed by OTA. The at-sea factor is the fraction of the submarine force that is always at sea. It is defined as:

$$\text{at-sea factor} = F_{AS} = (1 - F_o)$$

An at-sea factor of 55 percent is assumed in order to estimate the total number of required submarines. This factor is also used to estimate the number and size of base facilities required for servicing submarines between patrols.

In order to provide 100 at-sea missiles (or alternatively 1,000 surviving warheads) at all times, the at-sea reliability of the missiles must be factored into the sizing of the fleet. It is projected, from engineering requirements, that 95 percent of the missiles at sea would be in an up status for a fleet of submarines with an at-sea patrol of length 60 days.

## FINAL SIZING CONSIDERATION

In the final sizing of the system, it was assumed, in order to establish a conservative cost estimate, that 10 percent of the missiles might not function on a launch command and it would be necessary to maintain more than 100 "up" missiles at-sea. This assumption

added 4 submarines to a procurement which would otherwise have been 47. The costs of procuring, operating and supporting additional crews, missiles, capsules, and strategic weapons systems is of the order of \$1 billion to \$2 billion.

## LOCATION AND DESCRIPTION OF BASES

Base selection was limited to the continental United States since the submarine force is designed to operate in deep ocean areas adjacent to the continental United States.

The perceived need for responsiveness, flexibility, and weapon system effectiveness dictated that the submarines be able to move rapidly to acoustic transponder fields to main-



tain accuracy in the event of outage of the GPS. A very large operating area would spread the acoustic transponder fields over a large area of ocean, resulting in possible execution delays due to long transits to transponder fields. In addition, time on station could be maximized without the need of a submarine with a high transit speed. It should be noted, however, that none of the above considerations truly dictate a need for such a limited deployment area.

The Gulf of Mexico was rejected as a deployment area for the following reasons: diesel-electric submarine technology has achieved a level of quieting that would not restrict the submarines to acoustically shallow water even if a large-scale advanced passive sonar threat emerged. The acoustically shallow water of the Gulf of Mexico therefore offered no clear survivability benefits to offset the range/payload/accuracy missile performance penalties associated with that deployment area.

It is assumed that a detailed review of possible base locations would be made if there was a decision to deploy a fleet of small submarines. In order to provide a basis for estimating costs, three base locations on the east and west coasts of the continental United States and Alaska were assumed. These are:

- . Anchorage, Alaska
- . Puget Sound Area, Wash.,
- Narragansett Bay, R. I.

Each of the sites has problems of its own. The arctic winters, long winter nights, and extreme weather at the Anchorage site would pose problems clearing ice, loading and off loading missiles, maintaining and refitting submarines, and supporting crews at the base. The Puget Sound area already has a Trident base (Bangor, Wash.). Construction at the Narragansett Bay site could be delayed due to competition for the land from the Rhode Island Government.

Other possible secondary sites could be:

- San Diego, Cal if.,
- Charleston, S. C.,
- Kingsbay, Ga.

These possible sites also offer their own problems. San Diego would be unlikely to pro-

vide enough waterfront area without displacing existing Navy operations. Charleston and Kingsbay could be too far south for the most efficient deployment of submarines in the northern coastal areas of the Atlantic.

Since SSBN fleet support is shifting to Kingsbay, waterfront area may become available in Charleston for submarine support in Charleston while MX support might be provided at the new SW FLANT facility at Kingsbay. Tradeoff studies would have to be performed in order to evaluate the sensibility of these options.

In order to develop a conservative estimate of the size, number, and cost of facilities at the small submarine base, an analysis of the Trident base facility at Bangor was made. Approximately 85 to 90 percent of the land required for the base is dictated by explosive weapons safety requirements and facilities for handling strategic weapons. It was assumed that the amount of land required scaled with the number of strategic weapons on the base. This number includes the missiles on the submarines, missiles stored for operational tests, and missiles stored for demonstration and shake-down operations. These assumptions lead to the conclusion that 4,450 acres would be required for the base, other assumptions could lead to a smaller less costly base but they would only be justified if a more detailed feasibility analysis could be performed.

The size of the base arrived at for the costing analysis is approximately 500 acres larger than a base sized in an earlier study of small submarine basing performed by the System Planning Corp. for the Navy. Table 29 compares the estimated small submarine base with the Trident base at Bangor.

**Table 29.—Estimated Characteristics of the Small Submarine Refit Site and the Trident Refit Site**

	Small submarines	Trident
<b>Total area (acres)</b> .....	<b>4,450</b>	<b>8,397</b>
<b>Waterfront length (feet)</b> .....	<b>11,630</b>	<b>4,248</b>
<b>Number of submarines in port</b> .....	<b>5/6</b>	<b>3</b>
<b>Number of explosive handling wharfs</b> .....	<b>1</b>	<b>2</b>
<b>Number of refit berths</b> .....	<b>4/5</b>	<b>3</b>
<b>Drydockets/graving docks</b> .....	<b>1</b>	<b>1</b>

SOURCE: Off Ice of Technology Assessment.

Chapter 6

# AIR MOBILE MX

# Chapter 6.–AIR MOBILE MX

	<i>Page</i>
Overview. . . . .	217
Three Air Mobile MX Concepts . . . . .	219
The importance of Missile Size . . . . .	219
Continuously Airborne. . . . .	219
Dash-on-Warning With "Endurance". . . . .	221
Dash-on-Warning Without "Endurance" . . . . .	221
Survivability . . . . .	222
Aircraft Vulnerability to Nuclear Effects. . . . .	222
ICBM Barrage of in-Flight Aircraft. . . . .	223
SLBM Attack On Dash-on-Warning Air Mobile . . . . .	225
Endurance. . . . .	228
Costs . . . . .	230
Continuously Airborne. . . . .	230
Dash-on-Warning With "Endurance" . . . . .	230
Dash-on-Warning Without "Endurance". . . . .	231
Support Systems . . . . .	231
Warning Sensors . . . . .	231
Command, Control and Communications (C <sup>3</sup> ). . . . .	231
Missile Guidance. . . . .	232

## FIGURES

	<i>Page</i>
89. Survivability v. Escape Time . . . . .	226
90. Aircraft Survivability During Base Escape. . . . .	227
91. Aircraft Survivability During Base Escape. . . . .	227
92. Aircraft Survivability During Base Escape. . . . .	227
93. Aircraft Survivability During Base Escape. . . . .	227
94. Aircraft Survivability During Base Escape . . . . .	228

Air mobile basing offers the prospect of high survivability, since missile-carrying aircraft in flight would move much too fast to be targeted by Soviet missile forces. However, unless the aircraft were airborne continuously, their survival would depend on taking off upon early warning of attack. Moreover, they would have to find surviving airfields to land and refuel if they were to have endurance, i.e., to be a useful force beyond the first few hours of a war.

This chapter discusses three concepts, distinguished by their approaches to the problems of dependence on warning for survivability and postattack endurance beyond the unrefueled flight time of the aircraft. The basic concept (called below "Dash-on-Warning without 'Endurance'") would consist of missile-carrying aircraft on strip alert at a number of inland airfields. The force would take off on

warning of Soviet attack and would land and refuel after a few hours at existing civilian and military airfields unless the Soviets had destroyed these airfields. The second concept ("continuously Airborne") would avoid the problem of dependence on warning by maintaining the missiles in the air continuously. Such a system would be exceedingly expensive. The third concept ("Dash-on-Warning with 'Endurance'") would attempt to address the problem of postattack endurance by building a large number of recovery airfields throughout the United States, forcing the Soviets to attack all of them in order to deny endurance to the force. This concept would also be expensive. The base case, involving dependence on warning and no provision for endurance beyond existing airfields, could have a cost comparable to that of the baseline MPS system.

## OVERVIEW

The lowest-cost, base case air mobile system would consist of 75 or so wide-bodied aircraft, each carrying two MX missiles, maintained on strip alert at airfields located in the Central United States. Such a "dash-on-warning" air mobile force could be highly survivable. The principal threat to the force would be submarine-launched ballistic missiles (SLBMS) launched from positions near U.S. coasts. Such an attack could arrive in the vicinity of the alert airfields within 15 minutes of launch and seek to destroy the aircraft before they could take off and escape. However, if a high alert posture were accepted for the force, meaning that the aircraft took off immediately *on timely warning* of SLBM attack, almost the whole force would survive even if a large number of SLBMS was launched from positions near U.S. coasts. The Soviet SLBM force is presently incapable of such an attack, Air mobile basing could therefore stress Soviet strategic forces

where they would be least able to respond in the short term.

Nevertheless, the difference between survival and destruction of the force would be a very few minutes, depending on timely tactical warning. In this respect an air mobile intercontinental ballistic missile (ICBM) force would replicate a significant failure mode of another leg of the strategic Triad — the bomber force.

ICBMS, arriving later than the SLBMS, could not threaten the survivability of the entire force, since by that time the aircraft would have been in flight long enough to be dispersed over a wide area. Effective barrage attack of this entire area would require the Soviets to build many more large ICBM missiles than they now possess and use them to barrage approximately 1 million square miles (mi<sup>2</sup>). The outcome of such an attack would be insensitive

both to the fractionation (the apportioning of the missile payload among a small number of large-yield reentry vehicles (RVS) or a large number of smaller yield RVS) and to the accuracy of Soviet ICBM forces.

The principal disadvantage of a dash-on-warning force—the need for reliable, timely warning—could in principle be removed by having the aircraft maintain continuous airborne patrol. However, even with a new aircraft with lower fuel consumption, the cost of operating such a force would be prohibitive. A continuously airborne force of 75 aircraft (150 MX missiles) could have a lifecycle cost of \$80 billion to \$100 billion (fiscal year 1980 dollars).

A second crucial problem for an air mobile force concerns the question of postattack endurance. After a few hours of flight, the aircraft would have to land and refuel. Since their home airfields would be destroyed, they would have to find other places to land and await further instructions. This problem could be avoided completely if the United States were willing to adopt a policy of “use it or lose it” for the few hours of unrefueled flight. There are also several hundred civilian and military airfields in the United States capable of servicing large aircraft. Many of these airfields are located close to urban areas. If the Soviets wished to deny postattack endurance to an air mobile fleet—tantamount to forcing the United States to “use it or lose it”—they would have to attack these airfields. A serious effort to build more austere recovery airstrips throughout the country than the Soviets possessed ICBM RVS to destroy them would be enormously expensive, would have substantial environmental impact, and would be completely impractical if the Soviet threat grew large. For instance, 4,600 airfields spaced 25 miles apart would fill the entire 3 million mi<sup>2</sup> of the continental United States. Closer spacing might be possible, but beyond a certain point the spacing would become so close that local fallout from attack on one airfield would make extended operations at neighboring airfields impossible. Thus, cost aside, it might be impossible to guarantee survival of usable recovery airfields against a greatly expanded Soviet ICBM arsenal.

There could conceivably be some value in having more airfields suitable for air mobile operations than the Soviets had SLBM RVs. These airfields could be useful if the United States doubted the reliability of its SLBM warning sensors and wished to relax the force's alert posture (since, in a crisis, false-alarm takeoff might be mistaken by the Soviets for preparation to launch the MX missiles), or if the fleet were somehow “spoofed” into taking off (thus making a portion vulnerable as the aircraft were forced to land).

There are about 2,300 airfields in the United States that, with upgrades, could accommodate an air mobile force in the postattack period. However, to make use of most of them, it would be necessary to deploy smaller short-takeoff aircraft. Since the smaller aircraft could only carry one MX missile, twice as many of them would be required to make a force equivalent to a wide-bodied jet force. Between the cost of the aircraft and the recovery airfields, a force with this dispersal option could cost \$10 billion to \$40 billion (fiscal year 1980 dollars) more than a wide-bodied jet force with no recovery airfields beyond existing large civilian and military airfields.

Thus, the lowest cost air mobile system would consist of wide-bodied jets, each carrying two MX missiles, with no extra recovery airfields beyond those large civilian and military airfields that exist at present. The cost of such a system would depend on whether it was desired to have 200 MX missiles on alert (100 aircraft), 100 surviving MX missiles (50 aircraft, assuming 100-percent survival with prompt warning and takeoff), or some other number. Although OTA has not performed detailed cost and schedule analysis for such an air mobile option, it appears that the cost of a force with 75 aircraft (150 MX missiles) on alert could be comparable to the cost of the baseline multiple protective shelter system and could be deployed in a comparable time.

An air mobile force would also require several supporting systems. First and foremost would be reliable sensor systems for timely warning of Soviet attack. Providing such sys-

terns would be technically feasible but would require time, money, and continued effort. The complex force management needs of the air mobile force after attack would require a comparably complex communications system.

**Last, providing** for missile accuracy comparable to (or even better than) land basing would require the Global Positioning Satellite (GPS) system or a Ground Beacon System (CBS).

## THREE AIR MOBILE MX CONCEPTS

### The Importance of Missile Size

The size and weight of the missile determine the type and number of aircraft needed for an air mobile force. A large missile like MX would require a large aircraft, and only one or two missiles could be carried by each aircraft. Large aircraft require long runways. Since the number of U.S. airfields with long runways is in the hundreds, whereas the Soviet ICBM RV arsenal is in the thousands, an air mobile fleet with large aircraft could not count on finding landing sites when fuel ran low several hours after a Soviet attack.

A smaller missile could be carried by smaller aircraft, and these smaller planes would have many more possible sites — including unprepared surfaces, highways, and even waterways if fitted with pontoons—for postattack reconstruction. On the other hand, a smaller missile would carry fewer RVS, meaning that a small-missile air mobile force would require many more aircraft in order that the total deployment have as many RVS as a large-missile force. This large number of aircraft would in turn be costly.

There is thus a tradeoff in cost between small and large missiles for air mobile deployment. This study considers only the MX missile, capable of carrying 10 RVS to intercontinental range.

The ground-launched MX missile weighs 190,000 lb. For the purposes of air launch, the first stage of the MX could be modified to reduce the missile weight to about 150,000 lb with no penalty in range or payload. This weight reduction would allow large aircraft to carry two MX missiles.

There are two reasons why an air-launched missile can be lighter than a ground-launched missile of equal range and payload. First, an air-launched missile begins its flight 10,000 to 30,000 ft higher than ground-launched missiles and therefore does not need propellant to carry it to that altitude. This effect is actually small. A much larger contribution to weight reduction comes from the fact that a missile that begins its flight at high altitude can accelerate faster. Ground-launched missiles must accelerate slowly because if they attained high speed within the atmosphere they could be damaged by dynamic pressures and aerodynamic heating. Slow flight means that the missile uses much of its propellant just holding itself up against the pull of gravity in the early part of its flight. An air-launched missile can accelerate quickly because by the time it attains high speed the air is too thin to damage it.

The higher thrust-to-weight ratio of the air-launched missile means that the MX first stage could be truncated to a point where the missile weighed only 150,000 lb. (A brand new missile could probably be designed to attain MX capabilities at even lower weight. Cylindrical geometry would also not be necessary for a new missile. )

For the purposes of this chapter, then, the MX missile with a smaller first stage and 150,000 lb weight will be assumed.

### Continuously Airborne

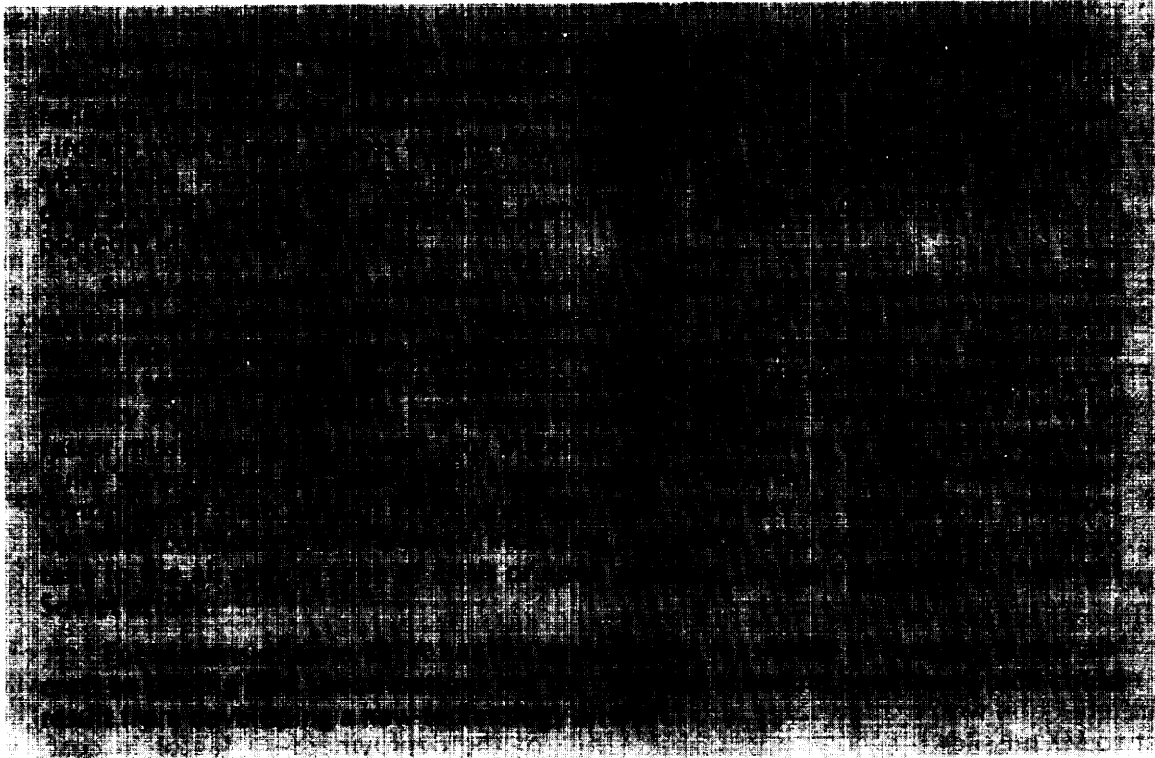
This concept might consist of a fleet of large turboprop aircraft, each carrying two MX missiles, maintaining continuous air alert. The size of the deployment — a factor in cost — would

depend on whether it was desired to have 200 alert missiles (100 airborne aircraft), 100 surviving missiles (50 aircraft, assuming perfect survivability), or some other number. The aircraft would maintain relays of 8-hour patrols, with 2-hour turnaround for each aircraft at the end of a patrol. Ocean patrol areas would remove the aircraft from congested overland air corridors and minimize the consequences of accidents involving the explosive propellants and nuclear warheads carried aboard.

Turboprop propulsion would reduce fuel consumption and prolong patrol cycles relative to conventional jet aircraft of the same size. No large turboprop aircraft are presently manufactured in the United States, but it would be technically feasible to develop a new aircraft, with consequent cost and schedule penalties. A four-engine turboprop aircraft of about 900,000-lb gross weight carrying two 150,000-lb MX missiles might be capable of 14 hours of unrefueled endurance and 2,500-mile range.

Continuously airborne operations would be, exceedingly expensive even for a turboprop aircraft. Such an aircraft might consume about 4,000 gal (27,000 lb) of jet fuel per hour. At the present price of \$1.17/gal, the fuel costs to maintain 75 aircraft (150 MX missiles) in the air 24 hours per day, 365 days per year, would be \$3 billion annually. Thirteen years of deployment (the average of 5 years of start-up and 10 years of full deployment) would mean a contribution of \$39 billion to lifecycle cost from fuel alone. Maintenance and crew costs would also be high.

The total lifecycle cost of a continuously alert air mobile system is estimated in the Costs section to be in the neighborhood of \$90 billion (fiscal year 1980 dollars) even without provision for postattack endurance. This cost exceeds that of other basing modes by about a factor of 2.



### Dash-on-Warning With “Endurance”

This concept calls for aircraft maintaining continuous ground alert at airstrips in the Central United States. A large number of additional airstrips is provided throughout the country for the aircraft to land and refuel in the postattack period.

A force of 150 aircraft, each carrying a single MX missile, would require 50 or more airfields, since the escape timeline would not permit them to line up and wait their turn to take off. Single airstrips wide enough to allow two aircraft to take off simultaneously in opposite directions would be ideal. Basing at least 700 nautical miles (nmi) from U.S. coasts would seek to keep the aircraft as far as possible from Soviet submarines. If the air mobile force were not to displace other Strategic Air Command alert aircraft nor be collocated with urban areas, some new airfield construction would be required. The airfields need not all be major airbases: most could be relatively austere runways with modest support equipment, with major maintenance performed at a few main operating bases.

Assured survival of a large fraction of the force against a large Soviet SLBM force deployed near U.S. shores would require high alert procedures. Since the difference between survival and destruction would be measured in minutes, the crews would have to be prepared to start engines immediately on receipt of a warning message. This preparation might mean stationing the crews in the cockpits at all times, a duty that some could find unattractive. Procedures calling for takeoff in response to a first warning message (not waiting for confirmation) would also imply a willingness to assume the consequences of an occasional false alarm dispersal of the aircraft, carrying their propellants and nuclear warheads. If the aircraft were capable of launching their missiles only while airborne, dispersal in time of crisis could be interpreted by the Soviets as preparation for a first strike.

Most studies of air mobile MX have considered providing a large number of austere airstrips dispersed about the country for the

aircraft to land, refuel, and await further orders in the postattack period. The number of airstrips of sufficient length, width, and hardness to accommodate aircraft of air mobile MX size is in the hundreds, whereas the number of Soviet ICBM RVS that could destroy them in the first half hour of the war is in the thousands. It is therefore plain that the air mobile force could not expect to find airfields for postattack endurance unless their number approximated or exceeded the number of Soviet RVS. The “austere” postattack airfields would have to be widely spaced in order that fallout from an attack on one field did not prevent the aircrews from remaining at adjacent fields for the hours or days of postattack endurance sought by building them. Providing 4,600 “austere” fields – equal to the number of aimpoints in the baseline MPS system — could result in a cost of about \$30 billion to \$40 billion to the air mobile deployment (see Costs section). If the airstrips were spaced 25 miles apart, 4,600 of them would entirely cover the 3 million mi<sup>2</sup> of the continental United States. The question of postattack endurance is discussed further in the Endurance section.

If construction of a large number of austere fields were contemplated, it would be desirable to minimize costs by deploying aircraft capable of using short runways. Several studies have discussed advanced medium short take-off (AMST) aircraft capable of carrying one MX missile. “Stretched” versions of the YC-14/15 have been considered as AMST candidates, but these aircraft were not originally intended to carry loads as heavy as the MX missile. The resulting designs called for rather extensive modifications and for runway lengths somewhat in excess of those normally considered for the AMST.

### Dash-on-Warning Without “Endurance” (Base Case Air Mobile System)

Considerable cost savings could be achieved by abandoning the requirement for a large number of austere airfields for use in the post-attack period. Since runway length would no longer be critical, conventional wide-bodied jets could be used, meaning that each aircraft



could carry two MX missiles. Such a force could use civilian or military airports for post-attack operations or, if these airfields were destroyed, adopt a policy of "use it or lose it" for the few hours of unrefueled flight time. The implications of such a policy are discussed further in the Endurance section.

Where it is necessary to be explicit in the following, a Boeing 747 will be assumed as the air mobile carrier. A Lockheed C5 could also be used. A suitably modified 747 capable of carrying two 150,000-lb MX missiles and their support equipment would have a takeoff gross weight of about 900,000 lb and carry 200,000 lb

of fuel at takeoff. The aircraft would have an unrefueled flight time of 5 to 6 hours and a range of 2,000 to 2,500 miles. The missiles would be carried one behind the other along the length of the fuselage, and a "bomb bay" would have to be provided in the aft fuselage for dropping the missiles out at launch. Since many commercial airlines are presently phasing some 747s out of their fleets, it is conceivable that used aircraft could be procured and modified for the air mobile mission. Since the aircraft would rarely fly, there might not be any need to have new ones.

## SURVIVABILITY

In comparison to other basing modes, air mobile has the attractive feature that its pre-launch survivability would be relatively insensitive to the size and nature of the Soviet ICBM force. During the half hour it would take Soviet ICBMS to arrive on the United States, the air mobile aircraft could have dispersed to an area so large that a barrage attack consisting of thousands of equivalent megatons would not destroy a majority of the aircraft. The outcome of such an attack would furthermore be insensitive to the number of warheads deployed on each Soviet booster and independent also of missile accuracy. Thus, air mobile deployment would remove all advantage to Soviet fractionation and accuracy improvements even if the Soviets were to contemplate a massive barrage attack on the Central United States.

The true threat to a dash-on-warning air mobile force would come not from the Soviet ICBM force, but from SLBMS, that have a flight time about half that of ICBMS when fired from near U.S. coasts. The area into which the aircraft could disperse in this time would be much smaller than the area they would cover at the end of a half hour, since the first few minutes would be consumed by receipt of the warning signal, engine start-up, taxiing, and initially low-speed flight. Still, SLBM attack would require a relatively large number of

Soviet submarines deployed near to U.S. shores. The present Soviet SLBM force is incapable of such an attack. Thus, air mobile basing would stress Soviet strategic forces where they would be least able to respond in the near term.

An air mobile force could therefore be highly survivable. However, the difference between survival and destruction of the force would be measured in minutes and would depend on receipt of reliable, timely tactical warning and high alert procedures. An air mobile ICBM force would share this sensitivity with the bomber force. Moreover, if the aircraft were unable to find airfields to land and refuel in the postattack period, their "survival" would be limited to the first few hours of the war.

There are many uncertainties regarding survival of aircraft to nuclear effects, and the results of calculations are in certain respects sensitive to the assumptions, but the overall trends support the generalizations made above.

### Aircraft Vulnerability to Nuclear Effects

Little of a definite nature is known about the effects on aircraft of nearby nuclear detonations. At low altitudes the dominant kill mechanism is probably the blast wave from

the detonation and especially the gusting winds that follow the shock front. These gusts could damage extended surfaces such as the wings and vertical stabilizer or cause engine stalling. Such effects would clearly depend on the orientation of the aircraft relative to the position of the detonation. At low altitudes (when escaping from their airfields) the aircraft would be below the "Mach stem" or point on the blast front below which the initial blast wave and the blast wave reflected from the Earth coalesce. For the low overpressures of relevance to aircraft, there is some uncertainty in modeling the front below the Mach stem. These uncertainties could result in rather large variations in the kill radius for aircraft of a given nominal hardness. It is also necessary to take into account the time elapsed between the detonation and the arrival of the shock front at the in-flight aircraft. All considered, a range in hardness from 1 to 3 pounds per square inch (psi) is probably appropriate.

At higher altitudes, the thermal radiation emitted by the detonation is probably lethal to the aircraft at a greater range than the blast wave. As the altitude increases, a smaller fraction of the weapon yield appears as thermal radiation, but since the air is thinner the radiation is attenuated less rapidly. The radiation is also deposited in a shorter time at high altitude. Melting or buckling of aerodynamic surfaces could result. The effects could again depend on the orientation of the aircraft with respect to the detonation. Thermal fluences of 20 to 40 calories per square centimeter ( $\text{cal}/\text{cm}^2$ ) or so are probably the limit for conventional aircraft with aluminum surfaces, but thermal hardening (at some weight penalty) could conceivably increase the thermal hardness as high as  $100 \text{ cal}/\text{cm}^2$ . An optimum cruise altitude, considering both blast damage at low altitudes and thermal flash at high altitudes, is probably 10,000 to 15,000 ft.

In addition to the immediate damage done by blast and thermal radiation, an air mobile force could also be affected by electromagnetic pulse (EMP), dust lofted by ground bursts, and crew radiation dose.

EMP would not affect crews or airframes, but could disrupt electronic equipment. There is a considerable amount of effort to harden other military aircraft to EMP, and it appears that with sufficient testing and attention to design details, the risk of disruption can be minimized.

Impairment of several aircraft flying through the dust cloud caused by the Mount St. Helens' eruptions has raised concerns for similar effects on aircraft operating after a nuclear attack involving a large number of groundburst weapons. Up to one-third of a million tons of dust per megaton of weapon yield could be lofted into the altitude range between 40,000 and 60,000 ft. Though aircraft would operate below this altitude, considerable dust densities could exist at lower altitudes for long periods of time as the dust at higher altitudes settled. Turboprop aircraft might fare better than conventional jet aircraft in these circumstances. However, this area is one of considerable uncertainty.

At the ranges from detonation where the aircraft itself would survive, the prompt radiation dose delivered to the aircrews would probably not result in mission-impairing sickness. If the aircraft were required to remain at austere fields subject to local fallout in the postattack period, however, there could be some danger of mission-impairing doses unless care was taken in the choice of airstrips.

In the illustrative calculations that follow, it will be assumed that, for a reference yield of 1.5 MT, the lethal radius for an aircraft at low altitude (during escape) is about 8 miles and at cruise altitude (10,000 to 15,000 ft) about 6 miles. These ranges correspond roughly to aircraft hardened to 1 to 3 psi overpressure and  $40 \text{ cal}/\text{cm}^2$  thermal fluence. *It should be remembered that there are considerable uncertainties in such calculations.*

### ICBM Barrage of In-Flight Aircraft

If the Soviets contemplated ICBM barrage attack on in-flight aircraft, either a continuously airborne force or a dash-on-warning force,

expenditure of considerable megatonnage would be required to destroy an appreciable number of aircraft. optimum burst height would be at the aircraft cruise altitude (10,000 to 15,000 ft, as discussed above). The outcome of such an attack would be insensitive to both weapon accuracy and fractionation of missile payload, as discussed further in chapter 8. Because of the burst height, there would be little prompt fallout and less damage to ground structures than for near-surface bursts.

#### Attack On Continuously Airborne MX Fleet

Five thousand I-MT weapons could destroy all aircraft within an area of about 600,000 mi<sup>2</sup>. Since a continuously airborne air mobile fleet could be dispersed over an ocean area totaling millions of square miles, even a very large attack could not significantly reduce the force. If the aircraft could be tracked continuously (methods for tracking are discussed below), and the Soviets could retarget their ICBMS continuously on the basis of up-to-the-minute aircraft locations, the aircraft could travel far enough in the half-hour ICBM flight time to escape direct attack. For instance, if an aircraft cruised at 400 mph, at the end of a half hour it could conceivably be anywhere within a circle of area 130,000 mi<sup>2</sup> about the point where it was located when the ICBMS were launched. A full 1,000 MT would therefore be required to destroy it with certainty.

#### Attack On Dash-on-Warning Fleet

Within a half hour of takeoff, a fleet of air mobile aircraft located at bases within the north-central region of the United States at least 700 nmi from the coasts could be dispersed over an area totaling about 1 million mi<sup>2</sup>. The Soviets could therefore destroy about one-eighth of the force (perhaps 20 or so MX missiles) for each 1,000 MT expended. Destruction of a sizable fraction of the force would therefore require an enormous expenditure of megatonnage. It is not clear that such an attack would in any case be appealing to the Soviets in all circumstances, implying as it would (for the low cruise altitude assumed)

widespread destruction in the entire Central United States.

#### Advanced Threats to Airborne Aircraft

It is possible to imagine several means by which in-flight aircraft over the United States could be tracked continuously by Soviet sensors. All of these means would be subject to U.S. countermeasures. Since, as described above, even continuous retargeting of ICBMS on the basis of up-to-the-minute knowledge of aircraft locations could be unprofitable if the aircraft speed were high, exploitation of a continuous tracking capability would require that the ICBMS be able to be retargeted in flight. This brief section describes some of the means to track aircraft and the possibilities for in-flight correction of ICBM trajectories. However, even if in-flight correction were feasible, Soviet dependence on any such strategy for attacking air mobile MX would entail risk and be subject to U.S. countermeasures.

Probably the easiest means to identify and track aircraft would be to direction-find on their radio emissions. To counter this threat, an air mobile force could observe radio silence whenever possible and stagger broadcasts so that all planes could not be located simultaneously. Above all, it could use communications not susceptible to intercept.

Large over-the-horizon radars based in Cuba could probably maintain coverage of the entire United States but would not be able to localize aircraft well enough to support effective retargeting. They would also be susceptible to jamming. Space-based radars would have to be relatively large in number, would have difficulty with ground-clutter background, and could be jammed. It might be possible to locate the aircraft by intercepting reflected signals from the Federal Aviation Administration radar network. Receivers used for this purpose might be jammable.

Space-based short-wave infrared sensors could attempt to observe the hot exhaust gases from aircraft engines, but the power levels would be exceedingly low, especially if the air-

craft cruised at low altitudes. Means to cool and diffuse aircraft exhaust are also possible. Long-wave infrared sensors would seek to observe the cool body of the aircraft against the warm earth. Again, this technique would be difficult in the best of circumstances and could be defeated by emissive body paints and heaters in the skins of the aircraft. All infrared devices could be defeated by cloud cover. If the aircraft cruise altitudes were in the 10,000- to 15,000-ft range, average U.S. cloud cover might obscure about a third of the force at any given time.

Since jet aircraft could travel about 200 miles in a half hour, substantial trajectory corrections would be required if an RV were to be retargeted *during flight* to an impact point near the aircraft. A maneuverable reentry vehicle could not make this large a correction using aerodynamic maneuvers. Midcourse velocity corrections of a few thousand feet-per-second would be needed for ballistic RVS. The link from the sensor tracking the aircraft to the in-flight RV could be jammed. Significant payload penalties (at least 50 percent) would also result from the need for receiving equipment and active propulsion.

### SLBM Attack On Dash-on-Warning Air Mobile

Attack on the alert airstrips from Soviet submarines deployed near U.S. coasts would be the principal threat to a dash-on-warning air mobile fleet. Calculations indicate—given the usual uncertainties in such estimates—that the force would be highly survivable even against a rather advanced future Soviet SLBM deployment consisting of large numbers (20 or more) of Soviet submarines stationed very near to U.S. coasts, provided high alert procedures were adopted for the force.

The most important factors influencing the survivability of an air mobile force would be the procedures adopted by the United States to ensure rapid takeoff in the event of attack and the size and deployment of a future Soviet SLBM force. These factors establish the impor-

tant trends. The precise numerical results also depend on aircraft hardness to nuclear effects, the way the Soviet attack was structured (lay-down pattern, height of burst), the flyout pattern of the aircraft (range, altitude, and direction from airstrip as a function of time), and the distribution of escape airstrips with respect to distance from the coasts. The outcome of *any calculation should be viewed with these sensitivities and uncertainties in mind.*

### Alert Procedures

It would be crucial to the survivability of air mobile that the time between Soviet SLBM launch and aircraft brake release be as short as possible. This time would be the sum of the times to receive warning of Soviet attack, man the aircraft, and bring engines up to speed. As discussed more fully in the *Support Systems* section and chapter 4, it should be technically feasible to provide reliable warning sensors that would indicate SLBM launch within at least 1 minute. It would be possible to station crews in the cockpits of alert aircraft at all times, though this type of duty might well be unattractive to the crews. A jet engine can be started and brought up to speed in somewhat more than 1 minute.

Thus, a “breakwater to brake release” time delay of between 2 and 3 minutes is feasible, though perhaps optimistic.

Such an extreme alert posture could result in an occasional false alarm dispersal of aircraft, carrying their potentially explosive (at least in the nonnuclear sense) payloads. Public acceptance of this possibility would be important in maintaining this posture in the long term. If time-consuming procedures were instituted to double-check the accuracy of the warning message before the aircraft took off, survivability against surprise attack could be significantly reduced.

If the aircraft were able to launch their missiles only while airborne, such a false alarm dispersal could appear to the Soviets to be preparation for a U.S. first strike.

## Soviet SLBM Forces

Attack on air mobile would require large numbers of SLBMs deployed near to U.S. coasts. The effectiveness of an attack would depend on the number of SLBM missiles launched but would be quite insensitive to how the payloads were fractionated into RVS and to RV accuracy. Effectiveness would also depend on how close the submarines were able to approach to U.S. shores and the types of trajectories they flew.

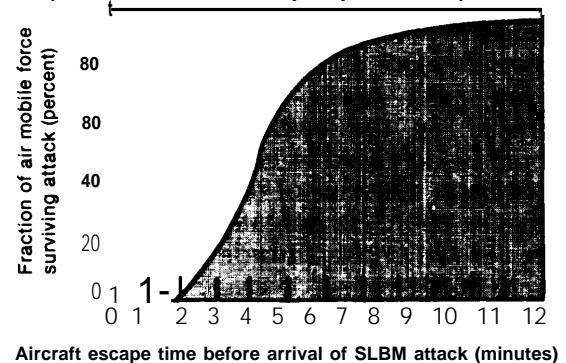
In order to destroy an appreciable fraction of the air mobile force, the Soviets would have to deploy a large number of submarines near to U.S. coasts and launch their missiles on special fast trajectories. The present Soviet SLBM force is incapable of such an attack. Soviet dedication of a future SLBM force to attacking a U.S. air mobile force could compete with other time-urgent missions involving both U.S. and European targets. It is also unlikely that the approach of large numbers of Soviet submarines to U.S. coastlines would go undetected. Short-term U.S. responses to such a "surge" could include diplomatic remonstrance, increased antisubmarine warfare efforts, and very high (perhaps even continuously airborne) alert procedures.

### Illustrative Calculations

Figure 89 shows the result of a typical calculation of air mobile survivability. The graph shows the fraction of the air mobile force surviving an attack plotted against "escape time"—the number of minutes the aircraft had to fly away from their bases (measured from brake release) before incoming SLBM RVS arrived to destroy them. The earlier the aircraft responded to a warning signal, the longer the escape time would be; the shorter the SLBM flight time (depending on the range and the type of trajectory), the shorter the escape time.

(The precise assumptions made in constructing figure 89 are: 747 flyout; simultaneous takeoff of two aircraft per base in opposite directions; about 8 equivalent megatonnage (EMT) targeted at each base; nominal aircraft hardness of 2 psi; inland basing.)

**Figure 89.—Survivability v. Escape Time (8 EMT on each airstrip, 2 psi aircraft)**



SOURCE: Office of Technology Assessment.

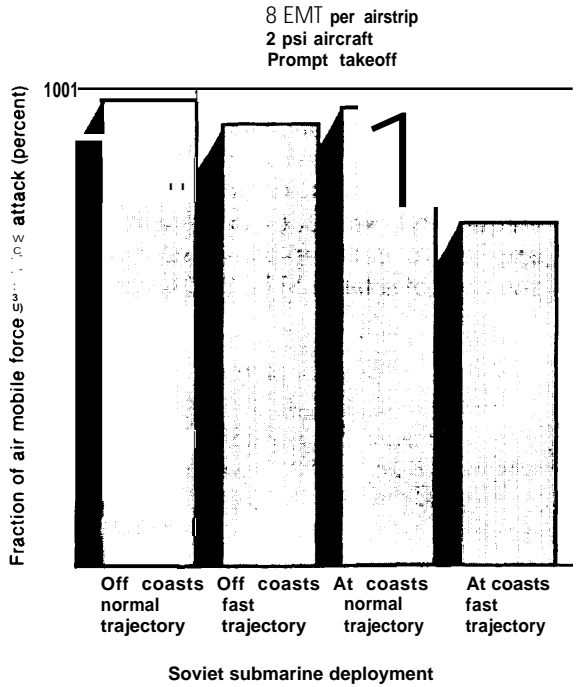
The curve in figure 89 begins at very low values (most aircraft destroyed) and climbs rapidly to rather high values (most aircraft survive). Whether the aircraft survived an attack or not would clearly be a matter of a very few minutes.

Where the outcome of a given attack fell on the curve of figure 89 would depend on the Soviet SLBM deployment. The various possibilities—launch from offshore patrol areas (hundreds of miles from U.S. coasts) or from positions at the coasts, on normal or special fast trajectories—would result in the approximate values shown in figure 90 for the survivability of the air mobile force. Figure 91 shows the result of delaying takeoff by 2½ minutes, either because crews were not stationed in the cockpits or because confirmation of warning was required before takeoff. Figure 92 shows the effect of increasing the size of the attack (measured in EMT) on each alert airstrip. Figure 93 shows the combined effects of both delayed takeoff and increased attack size. Finally, in figure 94, takeoff is delayed and the attack size increased, but the aircraft hardness is also increased from a nominal value of 2 to 5 psi.

These figures support the following conclusions:

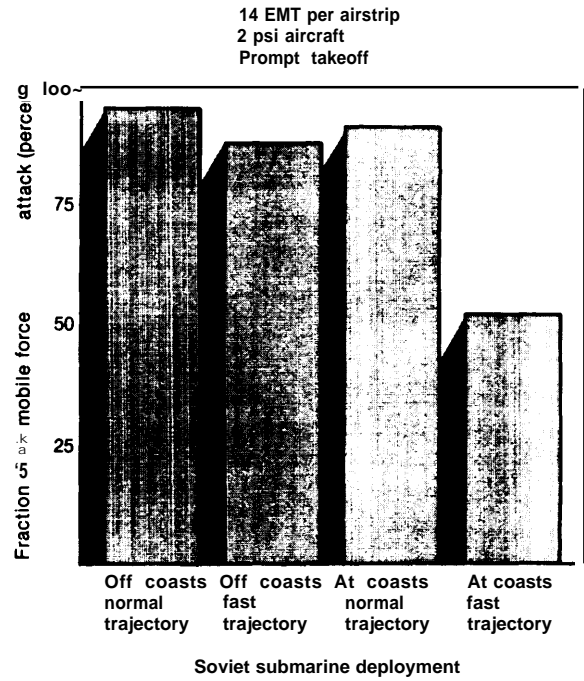
- The dash-on-warning force would be highly survivable against all attacks except those involving fairly large numbers of SLBMs launched on fast trajectories from positions actually at the U.S. coastline.

**Figure 90.—Aircraft Survivability y During Base Escape**



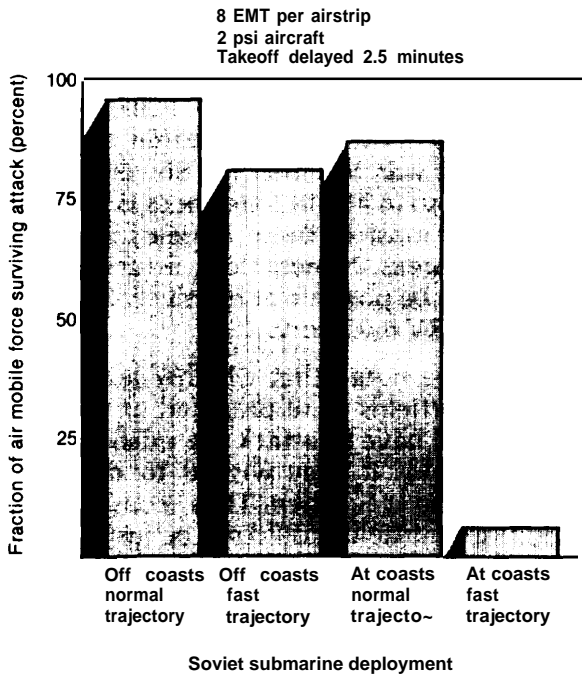
SOURCE: Office of Technology Assessment.

**Figure 92.—Aircraft Survivability y During Base Escape**



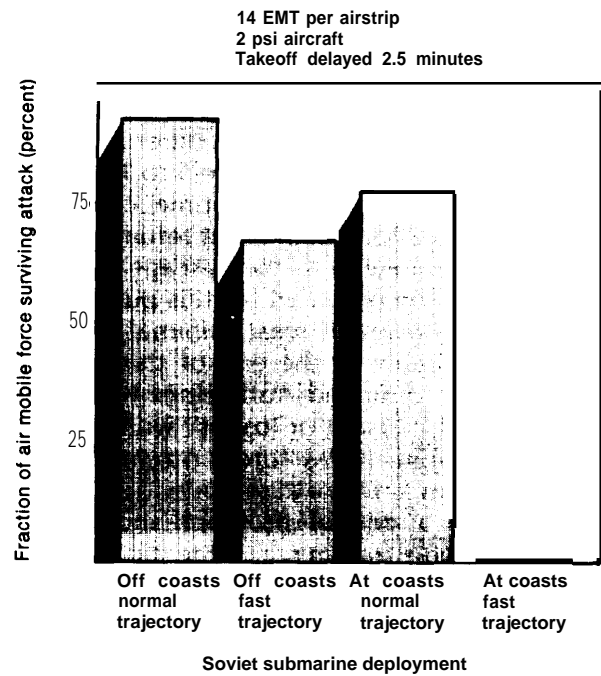
SOURCE: Office of Technology Assessment.

**Figure 91.—Aircraft Survivability During Base Escape**



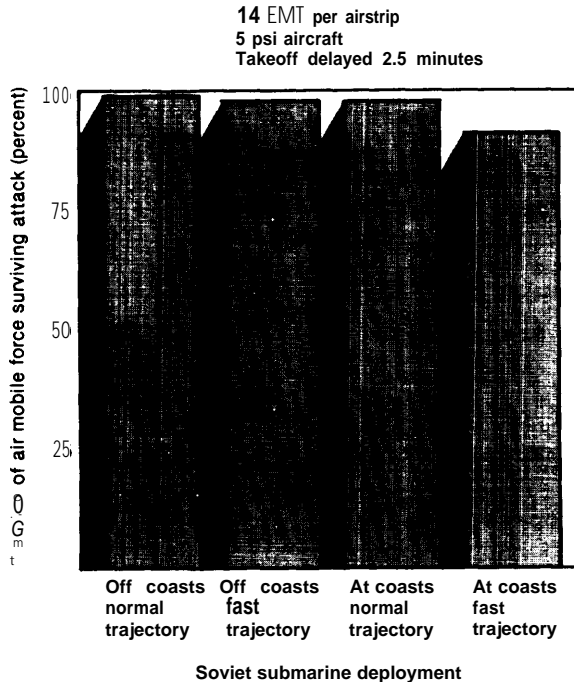
SOURCE: Office of Technology Assessment.

**Figure 93.—Aircraft Survivability y During Base Escape**



SOURCE: Office of Technology Assessment.

**Figure 94.—Aircraft Survivability During Base Escape**



SOURCE: Off Ice of Technology Assessment.

- The effect even of this rather advanced threat could be offset somewhat by high alert procedures.
- Significant aircraft hardening, if feasible, would restore high survivability even in the face of an advanced threat.
- Further airfield construction, so that there was one airstrip per aircraft (or even several, with the aircraft moving among them frequently), would, by decreasing the EMT applied to each, improve survivability in the face of a large SLBM deployment.

## ENDURANCE

If the air mobile force survived the initial attack, it would only be effective for the first few hours of the war unless provision were made to land and refuel the aircraft. The unrefueled endurance of the aircraft would be 5 to 10 hours, depending on the type. This time could be more than doubled with in-flight refueling, but a fleet of tankers with its own escape airstrips would have to be provided for this purpose. If airfields capable of at least minimal support were not available at the end of this period, the National Command Authorities would be in a position of "use it or lose it" with respect to the air mobile ICBM force. Attempting to ensure endurance for an air mobile force could therefore be a critical problem and, if addressed by constructing a large number of recovery airstrips, a major cost driver.

A first possibility for postattack reconstitution would be use of the several hundred exist-

ing military and commercial airfields throughout the U.S. with runways long enough for the large MX missile carriers. Soviet ICBMS could easily destroy these airfields within the first half hour of a war. Whether the Soviets would choose to do so in all circumstances is another matter, since most of these airfields are near large urban areas. Nonetheless, attack on all would clearly be possible at relatively low cost to the Soviet RV inventory.

It should be noted that whether additional postattack airfields were provided or not, the Soviets would have to attack the existing commercial airfields if they wished to deny endurance to the U.S. force. Thus, construction of additional airfields could not be justified on the grounds that failing to do so would invite attack on all the Nation's airports: the very existence of these airfields, sufficient by themselves to support air mobile in the postattack

period, would make them targets no matter what else the United States built. Independent of whether extra recovery airstrips were built, air mobile deployment would face the Soviets with the choice of attacking a large number of urban/industrial targets (and forcing the United States to a "lose it or use it" posture) or granting endurance to the U.S. force.

A second approach to endurance would be to construct a large number of "austere" or minimally equipped recovery airstrips throughout the United States. These airstrips would have to have at least an adequate runway and fuel supply. They would have to be spaced far enough apart so that fallout from attack on one would not make it impossible for aircraft crews to remain at neighboring airstrips for the hours or days of postattack endurance sought by building them. It would also be desirable, if not necessary, to equip each field with landing aids (beacons or radar reflectors) and perhaps also crew shacks, floodlights, fences, snowplows, and the like. Equipping each of thousands of airfields with such provisions would be exceedingly expensive. Alternatives could include providing road-mobile recovery teams to meet the aircraft at the recovery sites or providing a fleet of aircraft loaded with supplies, on alert like the missile fleet, to accompany the aircraft.

A serious effort to build more austere recovery sites than the Soviets possessed RVS to destroy them would be enormously expensive and completely impractical if the Soviet threat grew large. There are about 2,300 airfields in the United States with runways 2,500-ft long and 40-ft wide, that are of medium hardness. Most of these fields are wholly inadequate to support aircraft the size of MX carriers and would need substantial improvement. Construction of an additional 2,300 recovery fields, to make a total of 4,600 (the number of aimpoints in the baseline MPS system), would be much more expensive still. If these recovery fields were located 25 miles from one another, they would cover the entire 3 million mi<sup>2</sup> of the continental United States. If the numbers were made larger still, the packing could be so close

that attack on one could make neighboring fields unusable.

It would thus be impossible to *guarantee* postattack endurance for an air mobile MX force against a large Soviet threat. As a practical matter, it would only be possible to force on the Soviets the choice of granting endurance to the U.S. force or attacking a large number of targets spread throughout the country. How many airfields, if any, the United States constructed would thus seem to depend on what number, if any, would induce the Soviets to give up targeting them. Alternatively, the United States could take the position that if the Soviets were willing to attack sites throughout the United States, the United States would be willing to adopt a "use it or lose it" posture. In this case the number of recovery airfields built would be decided according to the amount of damage the United States would tolerate before such a posture became acceptable to U.S. policy makers.

There could conceivably be some value in having more airfields suitable for air mobile operation than the Soviets had SLBM RVS. These airfields could be useful if the U.S. doubted the reliability of its SLBM warning sensors, wished to relax the force's alert posture, or were somehow "spoofed" into dispersing the air mobile fleet. If the number of dispersal fields were larger than the Soviet SLBM inventory, a force that in a crisis moved randomly and frequently among them would have a measure of survivability even in the absence of warning of SLBM attack. ICBM RVS arriving in larger numbers a short time later than the SLBMS could still destroy the force, so the dependence on warning would still not be wholly removed. Transit to a "hop and sit" posture would also allow some relaxation of alert procedures, alleviating the fear that takeoff in response to a false warning message (there being no time for confirmation) could be mistaken by the Soviets for preparation for a U.S. first strike (since the missiles *could only* be launched while airborne). Last, the aircraft would be vulnerable when they had to land following a "spoof" or small attack designed to



cause them to take off. A large number of landing sites would make attacking the portion of the fleet grounded at any one time as costly as possible to the Soviets.

Another possibility for recovery sites would be along stretches of the Nation's highways. Since M-X-sized missile carriers would need long and wide stretches of highway to land and take off, it might not be practical to depend on this method. The traffic density on most U.S. highways is prohibitively high, at least in nor-

mal circumstances. It is possible that some stretches of Midwestern highway could be used, but fuel caches and support equipment would have to be prepositioned or brought to the landing sites by road mobile vehicles (themselves subject to attack).

Endurance could clearly be a major problem for air mobile MX. The next section estimates the cost of providing large numbers of recovery airstrips.

## COSTS

OTA has not performed detailed cost analyses for the three air mobile MX configurations discussed in this chapter. What follows are *rough estimates* that seek to indicate overall orders of magnitude and to highlight the cost drivers. These estimates are based on air mobile MX analyses done by other Government agencies. However, since the outcomes are very sensitive to assumptions concerning the number and cost of aircraft and airfields, etc., these analyses could only provide a guide to the costs of the systems described here. The final results provided here probably reflect the true costs of the systems described to about 10 to 20 percent. Costs quoted are nominally in fiscal year 1980 dollars. These costs do not include the systems described in the *Support Systems* section nor the possible additional costs of hardening aircraft. Larger or smaller deployments than those considered here could lead to substantial changes in system costs.

### Continuously Airborne

This system would consist of 75 new large turboprop aircraft (150 MX missiles) continuously airborne and operating out of four new coastal main operating bases. Costs might be:

*Aircraft:* 75 patrol aircraft plus 50 for training and attrition, each costing \$80 million (including development costs): \$10 billion.

*Missiles:* missiles modified for air launch, including spares and test missiles: \$12 billion, including development.

*Bases:* Four main operating bases: \$4 billion.

*Operations, excluding fuel:* \$2 billion per year for 13 years (average of 5 years of startup and 10 years of full deployment): \$26 billion.

*Fuel:* Round-the-clock flight of 75 aircraft at \$1.17 per fuel gallon for 13 years: \$39 billion.

*Total:* \$91 billion.

### Dash-on-Warning With "Endurance"

This concept consists of 150 AMST aircraft (carrying 150 MX) on continuous ground alert at 75 inland airfields. Also provided are 2,300 to 4,600 recovery airfields. Three cases are considered:

- Case A: Minimal upgrades to 2,300 existing airfields, including hard gravel lengthening and fuel caches.
- Case B: Same fields as case A with addition of landing aids, floodlights, security fence, snowplow, crew shack, 2-man permanent crew, and other supplies.
- Case C: Additional 2,300 airfields built from scratch and equipped as in case B.

*Aircraft:* 85-percent reliability implies 180 alert aircraft plus another 50 for training and attrition at \$50 million each: \$12 billion.

*Missiles:* As above, \$12 billion.

*Alert bases:* 75 Central U.S. airfields, including some existing joint civilian/military airports, with 6 main operating bases: \$4 billion.

Operations (1 3-year average):

Case A: \$18 *billion*.

Case B: \$24 *billion*.

Case C: \$28 *billion*.

Recovery airfields:

Case A: \$4 *billion*.

Case B: \$10 *billion*.

Case C: \$25 *billion*.

Total:

Case A: \$50 *billion*.

Case B: \$62 *billion*.

Case C: \$87 *billion*.

fields. No provision is made for postattack endurance.

*Aircraft*: 85-percent reliability implies 90 alert aircraft plus another 40 for training and attrition, at \$60 million each: \$8 *billion*.

*Missiles*: As above, \$12 *billion*.

*Alert bases*: 38 Central U.S. airfields, 4 main operating bases: \$3 *billion*.

*Operations*: 13 years: \$77 *billion*.

*Total*: \$40 *billion*.

## Dash-on-Warning Without “Endurance”

This concept consists of 75 wide-bodied aircraft (150 MX) on ground alert at 38 inland air-

## SUPPORT SYSTEMS

### Warning Sensors

The survival of a dash-on-warning air mobile MX force would be critically dependent on receipt of prompt, reliable warning of Soviet SLBM launch. As discussed more fully in the context of launch under attack (ch. 4), it would be technically feasible with *cost and continued effort* to provide a variety of tactical warning systems which, taken together, would be exceedingly difficult for the Soviets to disrupt. These warning sensors could include high-orbit short-wave infrared satellites, ship-based and coastal radars (the latter defended with a “threshold ABM” if desired), and airborne infrared sensors and radars. It would also be technically feasible, again with cost and effort, to secure the communications links from the sensors to command posts and from command posts to the alert airfields.

Clearly, if the required money and effort were not dedicated to providing such warning sensors, a force that depended for its survival on a very few minutes of escape time would be endangered. No matter how much money and ingenuity were devoted to designing safeguards for the air mobile warning sensors, and even if these safeguards were very robust indeed, it would probably never be possible to

eradicate a lingering fear that the Soviets might find some way to sidestep them.

Public acceptance of the possibility of false alarm dispersal of the fleet would be essential to preserving a high alert rate in the long term. If the aircraft could only launch their MX missiles when airborne, false alarm disposal could be mistaken by the Soviets for preparation for a first strike.

### Command, Control, and Communications (C<sup>3</sup>)

A C<sup>3</sup> system capable of supporting the complex force management needs of an air mobile force would entail relatively low risk but could be quite costly. After dispersal, the aircraft would need to report their status [fuel remaining, missile readiness, etc.] to a central airborne command post and exchange information concerning the location and status of surviving recovery airfields. If a fraction of the force had been destroyed, there could be a need to exchange targeting information to ensure adequate target coverage.

While airborne, line-of-sight communications among aircraft via UHF would be possible at ranges up to about 300 miles. A UHF

"relay" from all aircraft to the command post could be established. Adaptive high frequency and very low frequency/low frequency could also be used. If the aircraft were dispersed at many recovery fields throughout the United States in the postattack period, some form of satellite communications would be highly desirable. High-orbit extremely high frequency satellites such as described in other chapters would provide survivable, high data-rate satellite communications to small, trainable dish antennas.

### Missile Guidance

Since the MX missile would be on a mobile platform for up to several hours before launch, accuracy would degrade relative to stationary deployment unless additional measures were taken. These measures might take several forms.

The most accurate would be external update, such as by the GPS or CBS that would provide position and velocity update to the missile's guidance system during cruise or during boost. Accuracies could be made comparable to land-based accuracies for update

during cruise and better for update during boost. The main disadvantage of these methods would be reliance on the survivability of the external aids. Secondly, in a nuclear environment the update information might not be transmitted through the ionosphere. This problem could degrade accuracy by 25 to 50 percent; however, the precise amount is uncertain.

A second method, that would be self-contained to the missile and aircraft, would be to use a detailed map of gravity disturbances and a high-class inertial measurement unit (IMU), such as the Advanced Inertial Reference Sphere in the missile. Such gravity mapping would be compatible with mapping programs utilizing SEASAT and GPS. Gradiometers might be more applicable to this method in their present state of development than to real-time navigation. Resulting accuracies might be some 70 percent degraded relative to land-based MX.

Finally, doppler radar and a high-class IMU, without external aids or gravity map compensation, might give the missile a circular error probable in the range 2,000 to 2,500 ft.

Chapter 7

# SURFACE SHIP BASING OF MX

# Chapter 7.— SURFACE SHIP BASING OF MX

	<i>Page</i>
overview .....	235
Factors Common to All Designs	235
System Description . . . . .	236
Operational Considerations . . . . .	238
Soviet Data Collecting Activities Relevant to the Vulnerability of MX-Carrying Ships . . . . .	239
Threats to MX Surface Ships. . . . .	240
Continuous Trailing . . . . .	240
“Delousing” of Trailers at Port Egress. . . . .	244
At Sea “Delousing” of Trailers . . . . .	244
Reacquisition of Trailed MX Ships	<b>245</b>
<b>Regions of Poor Visibility weather.</b>	<b>246</b>
<b>Final Comments on Trailing</b>	<b>247</b>
<b>Other Surveillance Technologies . . . . .</b>	<b>247</b>
<b>Over-the-Horizon Kaclars</b>	<b>247</b>
<b>Satellite-f Borne Sensors . . . . .</b>	<b>248</b>
MX Requirements and Surface Ship Fleet, . . . . .	250
Accuracy of Surface-Ship-Based MX . . . . .	251
Responsiveness of a Surface Ship <b>Force</b>	252
<b>F l e x i b i l i t y . . . . .</b>	<b>253</b>
<b>E n d u r a n c e . . . . .</b>	<b>253</b>
<b>Cost and Schedule . . . . .</b>	<b>253</b>

## TABLES

<i>Table No.</i>	<i>Page</i>
30 Number and Displacement of Ships in the World . . . . .	239

31 Operational Factors Affecting Fleet of Soviet Trailing Vessels . . . . .	241
32 SL-7 Specifications . . . . .	254
33 10-Year Lifecycle Cost. . . . .	254

## FIGURES

<i>Figure No.</i>	<i>Page</i>
95 Topside Arrangements . . . . .	236
96 Surface Ship Deployment Area. . . . .	238
97 Speeds of World’s Merchant Ships .. . . .	239
98 Displacements of World’s Merchant Ships . . . . .	239
99 Trailing Cycle Against MX-Carrying Surface Ships. . . . .	242
100 Geometry of Barrier Outside a Port With Unobstructed Access to the Sea . . . . .	243
101 Geometry of Barrier Outside a Port With Obstructed Access to the Sea. . . . .	243
102 Loss of Trail Probability Event Tree. . . . .	246
103 Regions Where Visibility is Often Poor . . . . .	246
104 Geometry of Over-the-Horizon Radar . . . . .	247
105 Radar Cross Sections of Two Similar Looking Ships at Different Over-the-Horizon Radar Frequencies. . . . .	248
106 Ground Track of Surveillance Satellite in a 24-Hour Period . . . . .	248
107 Observation Swath of Surveillance Satellite. . . . .	249
108 Single Satellite Repeat Coverage of Mid-North Atlantic in a 24-Hour Period . . . . .	249
109 Precession of Observation Swath on Two Successive Orbits of a Surveillance Satellite . . . . .	249
110 Search Schedule of Surveillance Satellites at Mid-Northern Latitudes .. . . .	250

# SURFACE SHIP BASING OF MX

---

## OVERVIEW

The object of basing the MX missile on surface ships would be to attain survivability by using both deception and large areas of ocean to exhaust or overwhelm Soviet ability to trail or maintain surveillance over the force. The fleet of MX-carrying ships would attempt to deceive Soviet trailers and sensors by looking like typical merchant ships. By operating within the 6,000- nautical-mile (nmi) range of Soviet targets, they could hide in between 50 million and 60 million square miles (mi<sup>2</sup>) of ocean. Since the ships would have to look like merchant ships, they would not be fitted with a launch pad. Instead, the ships would unload missiles directly into the water, and fire them from a floating position.

Surface ships appear attractive as a means for deploying the MX because they are easy to build. Therefore, if a policy decision were

made to deploy MX off land, it would be easier to build a fleet of surface ships than a fleet of submarines.

The choice of whether MX should or should not be deployed at sea is a matter of policy. Some of the views that argue for or against sea basing are presented in the discussion of small submarines (ch. 5).

In the discussion that follows, the features of surface-ship basing that are common to the concept are discussed first. Then a point design is presented and its survivability discussed. This section will be followed by a discussion of the accuracy, responsiveness, flexibility, and endurance that could be possible with a system of MX-carrying surface ships. In the final section, the cost and deployment schedule will be presented,

## FACTORS COMMON TO ALL DESIGNS

Surface ships are large floating objects. Consequently they can be observed at very great distances, under a wide variety of conditions, by a wide variety of sensors. The long distances at which ships can be observed and the ease of identification of ships create opportunities for very effective trailing operations as well as for very effective wide area search. This circumstance is fundamentally different from that of submarines.

In order to compensate for the fact that ships can be observed at great distances with modern sensors, the ships would be disguised to look like merchant ships and would patrol in very large areas of the ocean. They would sometimes mingle with other merchant ships in busy shipping lanes and at other times they would patrol in areas where Soviet surveillance is believed to be poor. The ships would have a speed sufficient to outrun trailing trawlers and commercial ships, light defensive ar-

maments, and electronic jamming and spoofing equipment.

A large fleet of MX-carrying surface ships would pose a considerable threat to the Soviet homeland and to Soviet strategic weapons systems. It could therefore be expected that the Soviets would be unlikely to ignore such a threat, and in response, might commit substantial resources to trailing and surveillance. Since Soviet ships would have to make long transits to and from home ports before attempting to trail MX-carrying surface ships, this deployment would result in a considerable expenditure of Soviet resources. This tactic could create resource problems for the Soviets and force them to divert resources from other military commitments.

The counter problem, from the American point of view, is that confidence in the survivability of the surface ships would be low.

There would be periods of time when the weather in the Northern Hemisphere would favor surveillance, tracking, and trailing. During these periods there would always be the possibility that large fractions of the fleet would be under surveillance or trail.

Under certain operational conditions, survivability of the force could depend on maneuvering duels between the trailers and the trailed ships. As adversaries developed familiarity with each other's operational procedures and capabilities, the initiative could constantly shift from one force to the other. The constantly shifting tactical momentum

between the different forces would have much of the unpredictability of a classical "war at sea" as forces maneuvered about, attempting to maintain an advantage. This situation could result in serious doubts in the minds of the public and decisionmakers about the survivability of the force in times of crisis.

The result of this constantly shifting circumstance would be that the vulnerability and the survivability of the fleet would constantly fluctuate. If the fleet were vulnerable during a time of crisis, a substantial incentive would exist to preempt before the opportunity was lost.

## SYSTEM DESCRIPTION

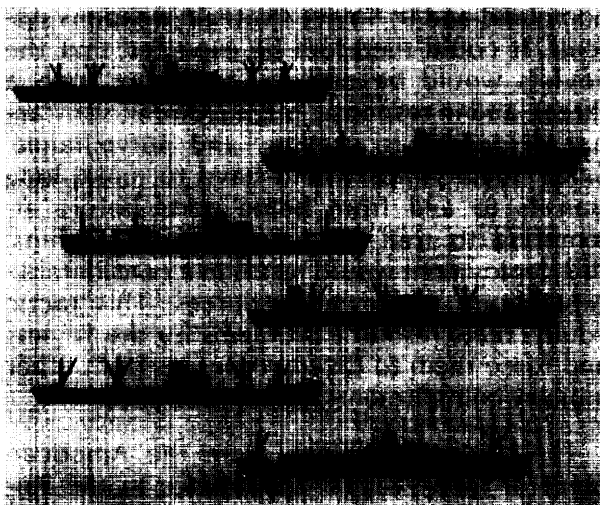
The fleet of MX-carrying surface ships would be made up of 30 fast merchant-like ships with movable superstructures, false hatches, and movable cranes and booms (see fig. 95). This equipment would allow them to change their appearance and complicate the process of radar satellite tagging of the ships. The ships would, in addition, be rigged with multiple sets of navigation lights so they could be made to change appearance to night observers. The ships would be constructed of lengths varying

between 550 and 650 ft and would have a displacement of between 15,000 and 20,000 tons. They would have an unrefueled-at-sea endurance of about 20,000 nmi assuming a patrol speed of about 20 knots. The ships would also have high-speed gas turbines in order to reach the 30 + knot speeds needed to break trail.

The ships are assumed to have an at-sea rate of about 80 percent (60 days at sea and 15 days in port). Missile reliability, extended refits and overhauls will result in a ship availability of less than 80 percent. (See ch. 5 for an explanation of the effects of overhaul, extended refit, and missile reliability on the availability of ships. ) If survivability fell below 50 percent, it would require an increase in the number of ships if the fleet is to be able to maintain the requisite number of survivable missiles on station. As will be demonstrated in the section on survivability, an assessment aimed at optimizing the at-sea rate and overhaul rate is not justified in light of the very large uncertainties associated with survivability.

Each ship would carry 8 to 10 MX missiles so that 200 MX missiles would be at sea at all times. This total would be an adequate number of MX missiles if the ships had a survivability rate of 50 percent. The conditions under which such a survivability rate might be achieved are discussed below in the section on survivability).

**Figure 95.—Topside Arrangements**



SOURCE: Office of Technology Assessment.

The ship would be equipped with Trident-like navigation and communications suites. Antenna masts would be disguised to look like normal merchant equipment or would be recessed so they could not be observed by aircraft, other ships or satellites. Jamming and electronic countermeasure equipment would also be available on the ship to aid in defense and to help confuse potential trailers. In addition to the Trident inertial navigation system, the ship's navigation suite would be equipped with a gravity gradiometer (assuming such gradiometers are successfully deployable on surface ships) and a system for interrogating acoustic transponders.

The ships would also be equipped with a sonar system that could be extended or withdrawn from recesses under the hull. This would give the ship a modest active and passive sonar capability against trailing submarines. It would also be possible to mount a far more capable sonar array on the bottom of the hull but this would be observable to submarines or divers and could be used as a means of "sorting" ships while at sea or in port.

Since the ships would have to be indistinguishable from merchant ships, their acoustic outputs would have to be comparable with those of merchant ships. Since merchant ships are considerably noisier than combat ships, it would be considerably easier for a distant trailing submarine or surface ship to maintain contact with the aid of a passive sonar system once the MX ship has been taken in trail.

The ships would have an onboard security force to protect the missiles and nuclear weapons in the event of an incident at sea. This force would be armed with conventional small arms and would also man the ships' defenses. Defenses might include heavy machine guns, rockets, cruise missiles, and light cannon. Perceived needs for heavier armaments would have to be balanced against the need to maintain deception. Provision would also be made for the destruction of the nuclear

weapons as a measure against the possibility of a successful boarding.

A system of 150 acoustic transponder fields would be secretly emplaced in the 50 million to 60 million mi<sup>2</sup> of the surface-ship deployment area. The transponder fields would make it possible for the ships to obtain extremely accurate velocity and position information for the missile guidance system prior to a launch. In the event of a need to use these transponder fields, the ships could proceed at 30+ knots to the nearest field. Fleet deployment to the fields could be affected within 11 to 12 hours.

The MX missile guidance system could be modified in a number of ways in order to achieve high accuracy at sea. A minimal modification would involve the development of software optimized for a purely inertial guided sea-based MX. A more involved modification of the guidance system would involve the use of a star tracker in conjunction with the MX inertial measurement unit. Still another modification of the guidance system would involve the use of radio beacons in conjunction with the MX inertial measurement unit. These methods of guidance, and their capabilities, are discussed in detail in the section on submarine basing of MX.

An additional activity aimed at achieving improved accuracy with the surface-ship-based MX would involve the measurement and use of gravimetric data for the deployment areas in which the ships operate. These data would then be used to correct for gravitationally induced missile guidance errors along flight trajectories.

The ships would deploy from two bases on the east and west coasts of the continental United States. These bases would have special shore facilities for assemblage, storage, and handling of MX missiles. In addition, explosive handling loading docks would be constructed so that damage from an accidental ignition or explosion of rocket propellant would be limited to the loading facility.



## OPERATIONAL CONSIDERATIONS

The fleet of surface ships would operate in an area as large as 50 million to 60 million mi<sup>2</sup> (see fig. 96). There would be a goal of operating in as large an area as possible to decrease the likelihood of surveillance. This goal would be constrained by the need to stay within missile range of Soviet targets.

The ships would attempt to remain covert using a variety of techniques. They would fly the flag of the country of registration and display the hull identification markers of a merchant ship.

The pattern of deployment would take advantage of shipping lanes, bad weather, day/night cycles, and intelligence on Soviet patrol activities. The ships would be in constant receipt of shore-to-ship very low frequency (VLF) signals. Since the ships would be on the ocean surface, they could also monitor shore-to-ship high frequency (H F) transmissions and satellite transmissions on a continuous basis.

There would be an operational need to report back to National Command Authorities (NCA) on a regular schedule to prevent the Soviets from attriting a large part of the fleet without U.S. knowledge. In addition, there

could be concern about the potential piracy of the nuclear weapons loads.

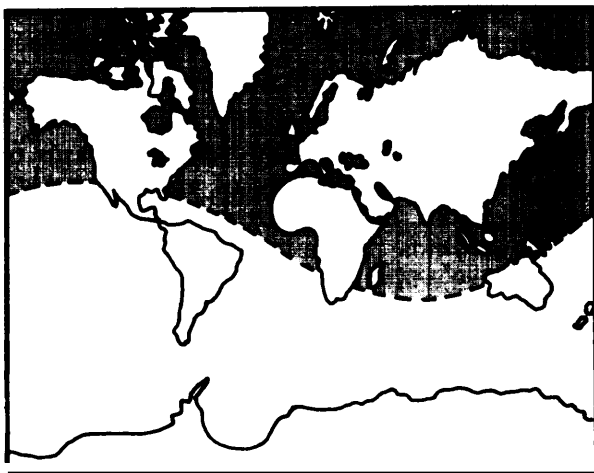
Report-back could be accomplished through high-orbit millimeter wave satellites. A 5-inch dish antenna could be used to report back to NCA on a regular basis. Since the beam from the ship-borne antenna would be very narrow, there would be a very low probability of transmissions being intercepted. The antenna would normally be recessed within a section of the ship so it could not be observed from other ships, aircraft or high-resolution satellite photography.

The ships could constantly monitor their position using the Global Positioning System (GPS) anywhere in the deployment area. On a command to launch, the missiles could be slid into the water from ramps deployed to the rear of the ship and fired from a floating capsule container.

Since sliding missiles into the water would be visible to a trailing observer, such a procedure would invite preemptive sinking of the ship. An alternative method of launch would be to carry the encapsulated missiles inside the hull and launch them through the bottom of the hull as the ship moves forward. The encapsulated missile would then rise to the surface behind the advancing ship. Upon breaching the surface of the water, its engines would be ignited and it would fly out of the capsule. In this manner, it would be possible to launch the missiles without providing a trailer with tactical warning of a launch.

Another possible means of obtaining navigational fixes would be to use the acoustic transponder fields that had been placed throughout the deployment area. If the GPS were attacked, these fields could be used when the the Ship's Inertial Navigation System (SINS) has to be reset. Deployment to acoustic transponder fields would take 11 to 12 hours, well within the period of time needed between updates (see ch. 5 for a more complete description of the SINS capabilities).

**Figure 96.—Surface Ship Deployment Area**



SOURCE: Office of Technology Assessment

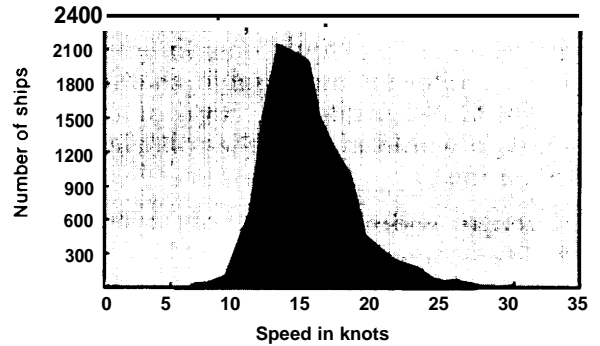
## SOVIET DATA COLLECTING ACTIVITIES RELEVANT TO THE VULNERABILITY OF MX-CARRYING SHIPS

The MX-carrying surface ship would carry 8 to 10 cannisterized MX missiles and would displace about 15,000 tons. The need to carry a heavy load of cannisterized missiles, to maintain at-sea endurance, and to have a high-speed capability dictates the size class of the ships.

Table 30 presents Department of Commerce statistics on the number and displacement of ships in the world. There are 5,094 ships with displacements greater than 10,000 tons and 1,561 ships with displacements over 15,000 tons. There are 130 ships with displacements over 15,000 tons that fly American flags.

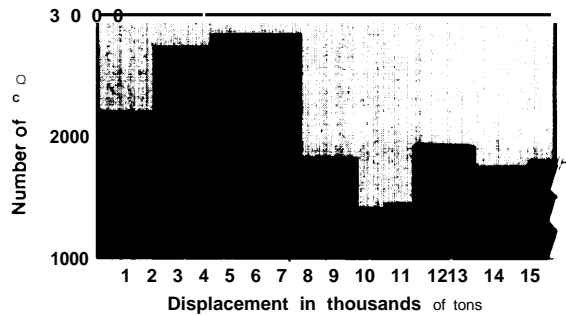
Figure 97 is a plot of the number of merchant freighters in the world versus speed. As can be seen from the plot, there are very few merchant ships in the world capable of being used to trail an MX ship with a 30 + knot burst speed. The bar graph in figure 98 shows the number of merchant freighters as a function of displacement. The graph shows that there are 1,400 to 1,500 merchant freighters in the world with displacement greater than 15,000 tons and about 1,400 merchant freighters with displacements between 13,000 and 15,000 tons. Between 1,500 and 3,000 of the world's 24,000 ships would be in a class that could potentially be mistaken for MX-carrying ships.

Figure 97.—Speeds of World's Merchant Ships



SOURCE: Department of Commerce

Figure 98.—Displacements of World's Merchant Ships



SOURCE: Department of Commerce

Table 30.—Number and Displacement of Ships in the World

World ships over 1,000 gross tons				
Total number of ships	Passenger and cargo	Freighters	Bulk carriers	Tankers
24,511	487	14,410	4,651	5,233
Merchant-type freighters over 1,000 gross tons				
World total	Foreign flag	U.S. flag total	Private	Government owned
5,094	4,657	437	260	177
Merchant-type freighters over 15,000 gross tons				
World total	Foreign flag	U.S. flag total	Private	Government owned
1,561	1,431	130	125	5

SOURCE: Department of Commerce.

Any sensible Soviet reaction to the deployment of MX-carrying surface ships would involve the cataloging of surface ships of the world. Such a catalog would include all free world surface ships of length, width, and displacement similar to that of the MX surface ships. The catalog would contain information about all relevant measurable characteristics that could aid in identification of the ships. Such data would include the following list of information:

- length, width, and draft of the ship;
- displacement;
- propulsion (steam, gas-turbine, diesel);
- side-view profiles;
- radar signatures at different frequencies;
- infrared signatures; and
- acoustic signatures.

Other ship features useful in "tagging" ships would be such identifiable characteristics as

hull length-to-width ratios; hull shapes; wake characteristics; and the positions of hatches, booms, and lifeboats. Much of this data could be obtained from standard sources on commercial shipping and the rest could be obtained by making measurements while ships leave and enter commercial ports. Data could also be collected by trawlers, surface combatants, satellites, submarines, and airplanes. These data could be correlated with data collected by shore observers on the characteristics, numbers, departure times, and destinations of merchant ships in deepwater ports around the world.

In the discussion that follows, it should be kept in mind that this background of data collecting would be an ongoing process, constantly being refined and updated, so that radar, infrared, optical, and acoustic data would be available for purposes of "sorting" ships.

## THREATS TO MX SURFACE SHIPS

The threats to a surface ship fleet fall into two broad categories:

1. continuous trailing of the MX ships so that a coordinated attack could be executed at will, and
2. wide area tracking of the surface fleet so that MX ships could be localized well enough to attack at will.

Continuous trailing would most likely be attempted by picking up the ships as they egress from known operating ports. Ports from which ballistic missile ships operate would have special facilities for loading MX missiles onto the ships. Since the missiles are very large and there are strict explosive handling safety requirements, these facilities would be easily identified by onshore agents or satellite reconnaissance. Ships that are pulled up to these docks could either be photographed by satellite or observed by onshore agents. These data would be added to the Soviet computer catalog of ship characteristics.

Wide area, open ocean search could be attempted with aircraft, satellites, or over-the-horizon radar systems. Since the area in which the ships would operate would be enormous, search by aircraft would be very difficult and expensive. Optimistically, a fleet of 600 to 800 long-range surveillance aircraft and 100 to 200 airborne refueling tankers would be required to localize enough ships in a short enough time to be able to destroy a large fraction of the force. Other wide area search techniques that would be more promising include infrared, optical, and radar search using satellite-borne sensors and over-the-horizon radar search using frequency scanning radars.

### Continuous Trailing

A potential Soviet response to the deployment of a fleet of MX-carrying surface ships could be to deploy a fleet of surface ships to maintain and establish trail on MX ships operating at sea. If a high percentage of MX

ships could be brought under trail, a preemptive strike could result in the loss of a large part of the MX fleet.

Establishing and maintaining trail at sea is not likely to be a simple matter. The success or failure of such operations will depend on the capabilities of the trailing ships, availability of support forces to aid the MX ships, tactics, and environmental conditions. There are also political and legal factors that could affect the activities and tactical options of both the trailing and trailed ships. Such factors are difficult to analyze in technical terms, since they basically involve violations or reinterpretations of international law of the sea. Operations or tactics that would require routine violations of international law are therefore not considered in detail in the technical assessment to follow.

In order to trail a fleet of MX-carrying surface ships, the Soviets might build a new type of surface ship with the necessary speed and endurance to transit from home ports, trail the MX ship for 60 days, and transit back home for resupply and refit. The surface ships would be equipped with surface search radars, infrared and optical search systems, and facilities for handling remotely piloted vehicles and/or helicopters. They would also be equipped with surface-to-surface cruise missiles, torpedoes, and possibly cannon. Possible ports from which the ships would operate might be Cuba, or Murmansk, Petropavlosk, and Vladivostok. Table 31 shows transit distances to ports that might potentially handle the surface ships.

In order for Soviet ships to continuously trail MX ships, one or more of these ships would have to be available to trail ships as they egressed from port. Figure 99 shows a possible schedule for keeping track of MX-carrying surface ships. The middle horizontal time line shows the total cycle for a Soviet ship-trailing mission against MX-carrying surface ships. The ship first transits to the port from which the MX ship operates, waits outside the port until the MX ship leaves on a sea patrol, trails the MX ship for the sea-patrol period, transits back home, and undergoes refit and resupply in its home port. The top and bottom horizontal time lines in figure 99 show the activities of

**Table 31.—Operational Factors Affecting Fleet of Soviet Trailing Vessels**

	Transit <sup>a</sup> distance (nmi)	Transit <sup>b</sup> time (days)	Base <sup>c</sup> loss factor	Required <sup>d</sup> number of ships
Murmansk to Norfolk .....	4,300	17.9	1.51	1.78
Murmansk to Cuba .....	4,600	19.2	1.53	1.80
Cuba to Norfolk ... , .....	870	3.6	1.23	1.45
Cuba to Charleston .....	610	2.5	1.20	1.41
Petropavlosk to Seattle .....	3,600	15.0	1.46	1.72
Petropavlosk to San Diego .....	2,800	11.7	1.40	1.65

a  $O_{10}^{\text{max}}$  transit distance,  
 b  $T_{10}^{\text{max}}$  transit time assuming 20-knot average transit speed.  
 c Assumes **ships spend 5** days in refit and an average of 7 days on Port watch waiting to pick up MX ships leaving port.  
 d Assumes that **15 percent** of the trailing ships are in overhaul at all times.

SOURCE: Office of Technology Assessment

other trailing ships that are either transiting from home base to take up position outside of port or transiting to home bases after having completed an at-sea trailing mission. The number of ships needed in order to keep one ship constantly available for trailing at sea would then be given by the expression:

$$B_{\text{tr}} = \frac{3 (\text{total cycle time}) - 2 (\text{TOW} + T_{\text{tr}})}{(\text{total cycle time})}$$

where:

$B_{\text{tr}}$  = base loss factor

total cycle time =  $2 T_{\text{tr}} + T_{\text{pw}} + T_{\text{refit}} + T_{\text{transit}}$

$T_{\text{pw}}$  = time spent in port watch

$T_{\text{trail}}$  = time spent trailing surface ship

$T_{\text{transit}}$  = time spent in transit to or from home port

$T_{\text{refit}}$  = time spent in port for refit

The base loss factor  $B_{\text{tr}}$  is simply the number of ships needed to keep a single ship on station at all times. Additionally, this factor must be adjusted for the percentage of ships that would be unavailable due to major overhaul activities in shipyards. The required number of ships would therefore be given by the expression:

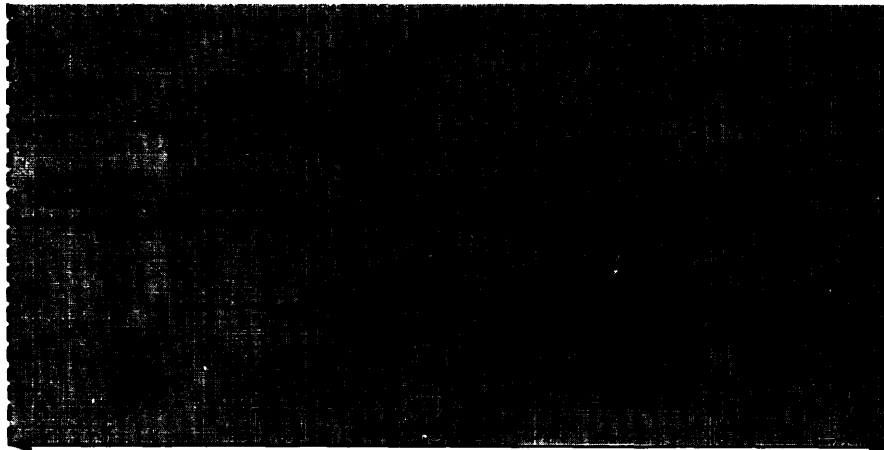
**Total number of ships required for trailing =  $\frac{(\text{number of MX ships}) (B_{\text{tr}})}{(1 - F_o)}$**

where:

$F_o$  = fraction of time ships in overhaul

Table 31 shows typical transit times to and from different Soviet ports to ports from which

**Figure 99** Trailing Cycle Against MX Carrying Surface Ships



SOURCE: Office of Technology Assessment

MX missile ships might operate. The base loss factors and number of ships necessary to continuously cover different ports are also presented. These factors were calculated assuming Soviet ships spend an average of 5 days in port changing crews and being resupplied and an average of 7 days on port watch waiting to pick up a trailing ship. It would therefore be necessary for the Soviets to build a fleet of 45 to 50 ships in order to have a ship continuously available at sea to pick up and trail surface ships as they leave port.

Initiating trail as the ship leaves port could be a potentially complex operation. A line of reconnaissance ships could be set up outside the port using relatively slow and inexpensive trawlers to patrol sectors of line. Onshore observers could also be used to inform ships on the line of departure of a surface ship. Surface search radars could be used to detect the egressing surface ship and imaging radars could be used as an aid to identification in fog. At night, infrared sensors and TV cameras could also be used. The ships on the reconnaissance line could also be equipped with remotely piloted helicopter vehicles and fixed-wing remotely piloted vehicles. These aircraft could be launched in good or bad weather to help cover large areas of the ocean. They would also be of use if multiple ships egressed

from port and it was necessary to obtain a high-resolution look at several ships in order to identify the MX-carrying ship. The number of fast-trailing ships kept on station outside the port would always be greater than or equal to the number of MX ships in port at any one time. Multiple egresses and surging of MX ships would be possible to complicate port-watch operations but this would have to be balanced against a requirement to keep missiles on station. If the missile ships were surged too often, it would result in periods where the United States would have more than the desired number of missiles on station and other times when the United States would have less than the desired number of missiles on station.

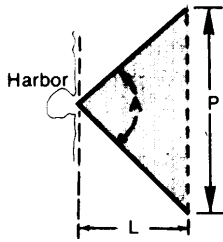
The number of ships required for the reconnaissance barrier can be estimated by considering the geometry of a port egress, number of MX-carrying ships in port, the range at which an MX ship can be detected, the barrier ship's ability to identify a ship as an MX carrier, and the rate at which multiple ships could exit the port. Figure 100 shows the geometry of a port egress for a range of exit tracks. The length of the barrier is:

$$\text{barrier length} = 2 L \frac{\sin A}{1 + \cos A}$$

where:

**L** is the territorial limit

**Figure 100.—Geometry of Barrier Outside a Port With Unobstructed Access to the Sea**



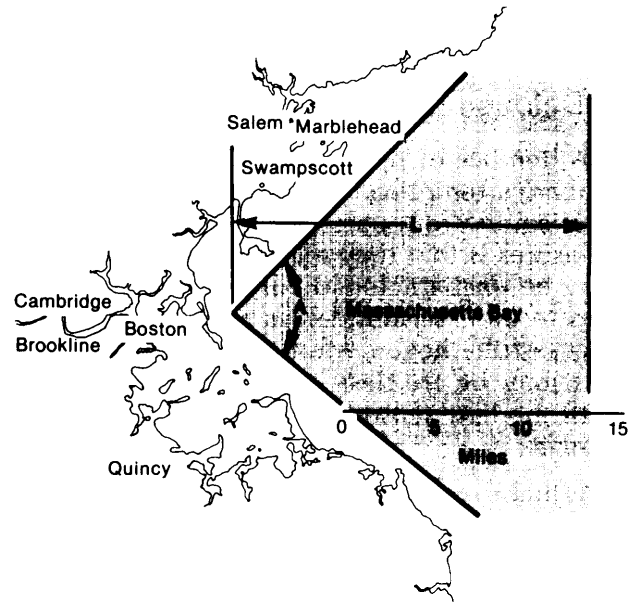
SOURCE: Office of Technology Assessment

Assuming that the territorial limit is 12 miles and the ships can exit within a cone of 150 the barrier length would have to be about 45 miles long. This geometry could apply to ports like San Diego, Charleston, Seattle, and San Francisco. Ports like New York and Boston have considerably more constricted access to the sea and would therefore require shorter barriers (see fig. 101). The average number of merchant ships leaving three major American ports are listed below:

Port	Average number of exits per day
Boston	10 to 20
New York	60 to 80
San Francisco	30 to 50

Two extreme cases are of interest: Ships exiting port at a uniform rate over a 24-hour period and ships exiting port at a maximum rate at one time. A maximum rate might be estimated by assuming that the ships would maintain 1,000 yd between them and exit at 10 knots. The maximum rate would therefore be one ship every 3 minutes. If the exits occurred during conditions of poor visibility, the ships might instead maintain a 2,000- to 3,000-yd distance and exit at 5 knots. This exit process would make the maximum rate one ship every 12 to 18 minutes. If the displacements of the exiting ships reflected that of the world's ocean going ships, 15 to 25 percent of the ships would be 15,000 tons or over. Thus, assuming a very busy commercial port could be used for deployment of nuclear armed MX ships, an exit rate as high as three to five ships an hour in the 15,000-ton class could be leaving port during

**Figure 101.—Geometry of Barrier Outside a Port With Obstructed Access to the Sea**



SOURCE: Office of Technology Assessment

peak periods of shipping. These ships could possibly be MX carriers and might have to be inspected at close range by the barrier patrol ships.

In actuality, it would probably not be necessary to inspect all these ships closely, since onshore observers could collect information on sailing schedules and send confirmation to the offshore ships on the sailing of the ship. It would therefore be necessary only for the barrier ships to leave their stations if it appeared that more ships of the right size were crossing the barrier than expected.

Assuming that the barrier ships used surface radars with a range of 5 miles, five ships would be required to maintain a constant barrier patrol. This total might be an adequate number for average peak sailing periods. Since the barrier ships would more closely approximate trawlers rather than the more expensive trailing ships, a prudent and determined adversary might commit two or three times as many ships.

If the port was not a major commercial port, then peak exit rates could only occur if several

ballistic missile ships exited at the same time. Since scheduling of trailing ships would be responsive to such fluctuations, additional long-range trailing vessels could be on station.

### “Delousing” of Trailers at Port Egress

A number of options are available to ships that are attempting to “delouse” themselves as they egress from port. The problem with such measures is that they may involve tactics that may be uncharacteristic of merchant ships or may result in serious delays before the patrol is successfully begun. More serious yet, the tactics may be fruitless against ships equipped with modern sensors. These tactics might include:

1. make repeated exit attempts until free,
2. use alternate port exits when available,
3. coast run to avoid the port watch barrier,
4. take advantage of dark and bad weather,
5. utilize military escorts to harass barrier ships, and/or
6. jam barrier ship sensors.

Tactics 1 through 4 would be very difficult to use successfully against ships equipped with modern sensors. Tactic 5 could create a large number of incidents that could have international repercussions. Tactic 6 would be very difficult to do if the ships were equipped with high-quality radars with good beam-forming and anti jam signal processing.

The success or failure of trailing operations would depend in a sensitive way on many details of ship operations, on the resolve of the trailing and trailed ships, the quality of the equipment available to each side, and on the resourcefulness of the different ship commanders. If the adversary is determined to commit the resources to establish trail, there appears to be little hope that the MX ship would “delouse” itself during egress from port. Once at sea, there also appears to be little opportunity for delousing. However, it could be argued that bad weather or tactical maneuvering could be used repetitively until trail is broken. This possibility is explored in the next section.

### At Sea “Delousing” of Trailers

It is of interest to determine how large a fraction of the force might be free of trail if it is assumed that bad weather or some other opportunity to break trail presents itself to the ships.

Low-visibility conditions at sea could be of use in “delousing” the surface ships. The percentage of maritime reports in which visibility is below 1 mile is about 5 percent.

If a low-visibility condition is assumed to exist for 1 day, then on the average, the probability of encountering such a weather condition during a patrol of length  $n$  days would be:

$$P = 1 - (\text{probability of clear weather}) \\ = 1 - (1 - 0.05)^n$$

or

$$P = 0.95 \text{ for a 60-day patrol (i. e., } n = 60)$$

**The probability of encountering low visibility weather on the  $i$ th day of the patrol would simply be:**

$$P_i = (\text{probability of } i-1 \text{ days of good weather}) \\ \times (\text{probability of bad weather on the } i\text{th day}) \\ = (\text{probability of one day's good weather})^{i-1} \\ \times (\text{probability of one day's bad weather}) \\ = (1 - 0.05)^{i-1} \times (0.05)$$

If the probability of breaking trail during low visibility is  $p_b$ , the expected number of days free of trail for a patrol of  $n$  days will be:

$$Q = (\text{probability trail will be broken}) \\ \times (\text{average number of days before bad weather is encountered}) \\ = P_b \times (\text{average number of days before bad weather is encountered}) \\ = P_b \times \sum_{i=1}^n (n - i) P_i$$

The fraction of the fleet under trail at any given time would be:

$$F = \frac{\left[ \begin{array}{l} \text{number of days} \\ \text{on patrol} \end{array} - \begin{array}{l} \text{number of days} \\ \text{free of trail} \end{array} \right]}{[\text{number of days on patrol}]} \\ = \frac{n - Q}{N}$$

For 60 days at sea ( $n = 60$  in the above summation), the average number of days free of trail would be about 12 days if the probability of

breaking trail during a day of bad weather is o.s. if the probability of breaking trail during a bad day of weather is 0.25, then the average number of days free of trail would be about 6. Thus, for the case where there is a 0.5 probability of losing the trailer when the weather is bad, the fraction of the fleet under trail will be:

$$F = \frac{60 - 12 \times (0.5)}{60}$$

or 80 percent of the fleet would be under trail.

For the case in which the chance of losing the ship during a bad day of weather was 0.25, the fraction of the fleet under trail would be:

$$F = \frac{60 - 6 \times (0.25)}{60}$$

or 90 percent of the fleet would be under trail.

If the ships could somehow choose weather conditions so that it was five times more likely that they would encounter weather with visibility of less than 1 mile, then the probability of encountering such weather on any given day would go from 0.05 to 0.25. If again it is assumed that the ships would lose their trailer with a probability of 0.5 on any day that such weather is encountered, the mean number of days free of trailers would rise to 28 and the fraction of the force under constant trail would be 50 percent. If the ships lost the trailer every time bad weather was encountered, the fraction of the force under constant trail would be only 7 percent.

### Reacquisition of Trailed MX Ships

The discussion above assumes that once the MX ship has been lost to the trailing vessel it is not reacquired during the remainder of its patrol period. If a search is immediately initiated once the trailer has lost the MX ship, and remotely piloted helicopters or remotely piloted winged vehicles are used, it is possible that the MX ship could be reacquired. If the remotely piloted vehicle could fly at 100 knots and had a modest radar with a range of 5 nmi, then the vehicle could search about 1,000 m<sup>2</sup>/hr. If the MX ship were to make a 30 + dash upon determining the trailer had lost contact (a questionable action if the visibility were

less than 1 mile and other ships were nearby), then it is conceivable that the ship could generate a large enough area of uncertainty to evade the drone vehicles. If the drone vehicle was not launched for half an hour after the trail was lost, the ship could be anywhere in a circle of radius 15 nmi. The trailing ship would be at the center of this circle of area 700 mi<sup>2</sup> when the drone is launched. If the drone flies in widening circles around the trailing ship it will have searched the 700-m<sup>2</sup> area within about 45 minutes. By that time the surface ship could be within an area of radius of 36 to 37 miles (an area of 4,300 mi<sup>2</sup>). The drone might therefore not acquire the surface ship in time if it is not launched quickly from the deck of the ship. If, instead, the drone is launched within 15 minutes after trail is lost, it could be expected to reacquire the ship with a probability of 1.

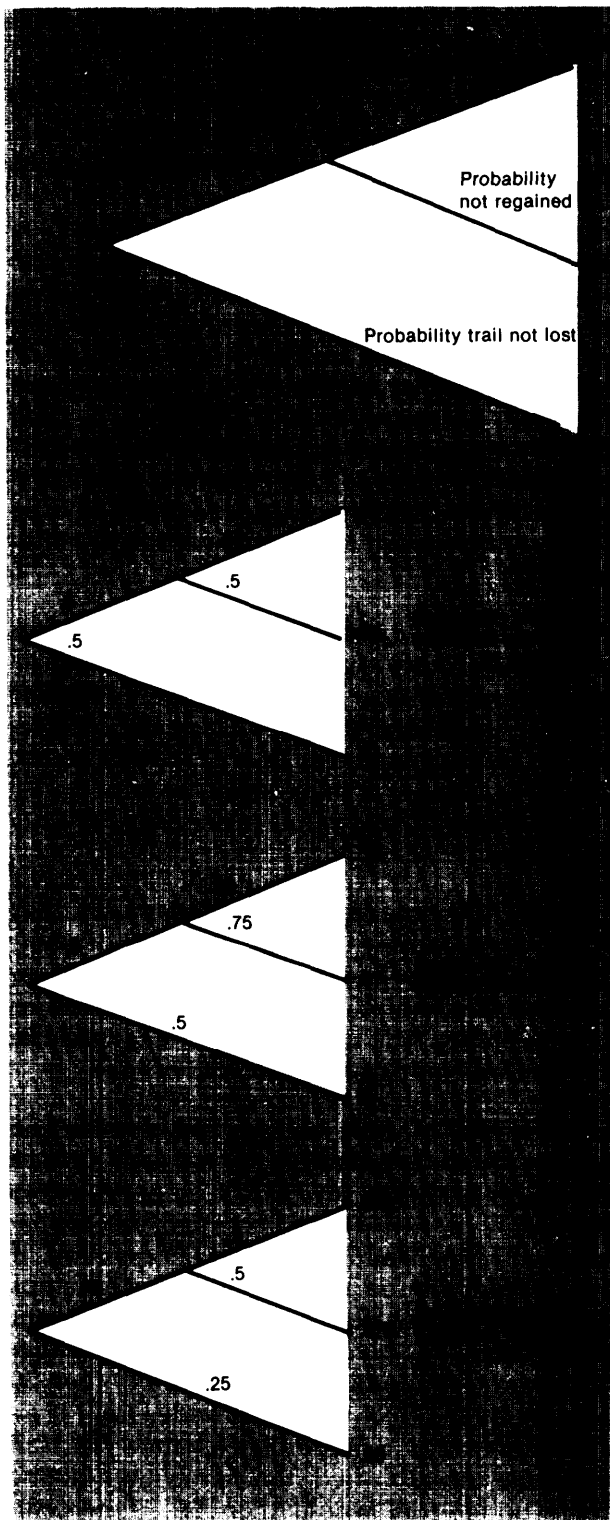
Since the ability to reacquire the target ship is sensitive to the capability of the drone (i. e., its radar might have a 10-mile range instead of a 5-mile range) and to how quickly the crew responds to the loss of trail, it is of interest to ask what percentage of ships would be kept under trail if the ships had some success reacquiring lost trails.

Figure 102 diagrams the possible events that might occur during a period of bad weather. The lower branch diagrams the situation in which trail is maintained during the period of poor visibility. The upper branch diagrams the events that could occur after loss of trail.

After loss of trail one of two events can follow: the ship reacquires the trail or it fails to reacquire trail. The lowermost diagram shows the result of a situation in which the probability of losing trail is very high (75 percent). If trail could not be reacquired and the ships were able to seek out poor weather 25 percent of the time (i. e., five times more bad weather than would randomly be encountered) then 30 percent of the fleet would be under trail. If instead there was a 50-percent chance the trail could be reestablished, the percentage of the force under trail would then be 37 percent. Therefore, the fraction of ships under trail



Figure 102.—Loss of Trail Probability Event Tree



SOURCE: Office of Technology Assessment

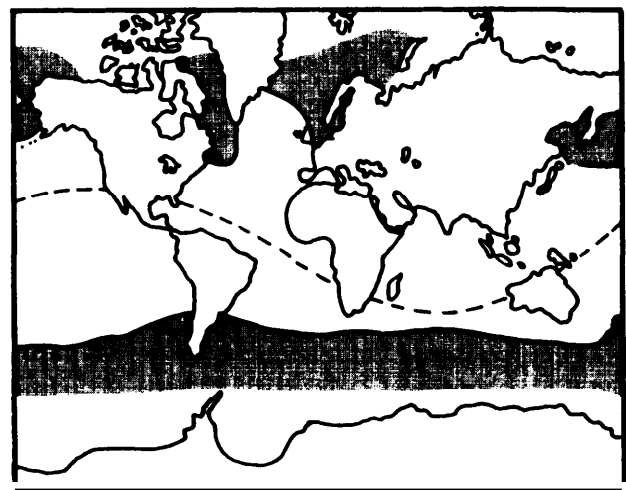
could change significantly if the trailing ships had a modest ability to reacquire trail.

It should also be noted that if a ship is taking advantage of bad weather to intermingle with other ships (so as to make it difficult for a radar operator to keep track of the MX-carrying ship) it is relatively easy to sort ships with the aid of fixed wing or helicopter-like drones. If the MX-carrying ship makes a dash at 30+ knots, its acoustic output would be enormous and it could be heard for many miles by the trailing ship. The ship could then send a drone in the direction of the acoustic signal to determine whether this was in fact the MX ship running for freedom, or just a decoy ship acoustically enhanced to sound like a fast running surface ship. In any case, the use of advanced pilotless drones with advanced sensors would make the reestablishment of a temporarily broken trail quite likely.

### Regions of Poor Visibility Weather

The shaded region in figure 103 shows areas of the world that have poor visibility a high percentage of the time. Due to proximity to the Soviet Union, Soviet air and ocean surveillance could be expected to be quite good in the northern regions near the Bering and Norwegian seas. Therefore, the regions of poor

Figure 103.—Regions Where Visibility is Often Poor



SOURCE: Office of Technology Assessment

visibility weather that could be used for attempting to break trail would be only the several hundred thousand square miles of ocean west of Greenland and north of Antarctica. These regions will have weather that varies significantly with changes in season. It could therefore be expected that if these regions were used extensively, the fleet could be seriously unmasked during periods of clear weather. Another problem encountered in these regions is ice. While it would normally not be considered prudent to operate in poor visibility weather without radar, it would be suicidal to do so in waters populated by icebergs. The radar emissions of the trailed ship could therefore be used as an aid for the trailing vessel during periods of poor visibility. The emissions would not exclude the trailer from also observing the trailed ship with its own advanced radars as well.

## Final Comments on Trailing

It should be clear from the above discussion that the survivability of a fleet of MX-carrying ships could be sensitive to operational details, capabilities of search radars and possibly weather. Advanced sensors and remotely piloted vehicles would substantially enhance the ability of a fleet of trailing ships to maintain trail. If there is a 5-percent chance per day that trail will be lost (either due to weather, at-sea tactics or equipment failures) as much as 45 to 50 percent of the fleet could be free of trailers. This circumstance, however, would be very unlikely with the variety, diversity and reliability of advanced sensing technologies that can be expected to exist in the late 1980's and early 1990's.

## OTHER SURVEILLANCE TECHNOLOGIES

Although trailing would be the most technologically conservative means of keeping track of the MX-carrying surface ships, there are a number of other important technologies that could either supersede the trailing threat or be used to aid the trailing vessels. These technologies are over-the-horizon radars and satellite-borne sensors.

### Over-the-Horizon Radars

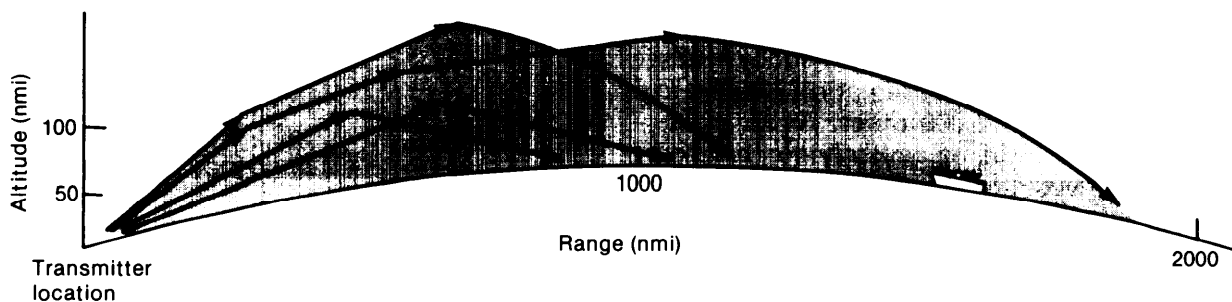
An over-the-horizon radar illuminates targets over the horizon by bouncing a radar

signal off the ionosphere (see fig. 104). The reflected signal from the target also bounces off the ionosphere before it arrives back at the radar receiver.

Over-the-horizon radars are restricted to frequencies no higher than that in the HF band since higher frequencies are not substantially reflected from the ionosphere. A consequence of such a low radar frequency is that the radar has low resolution.

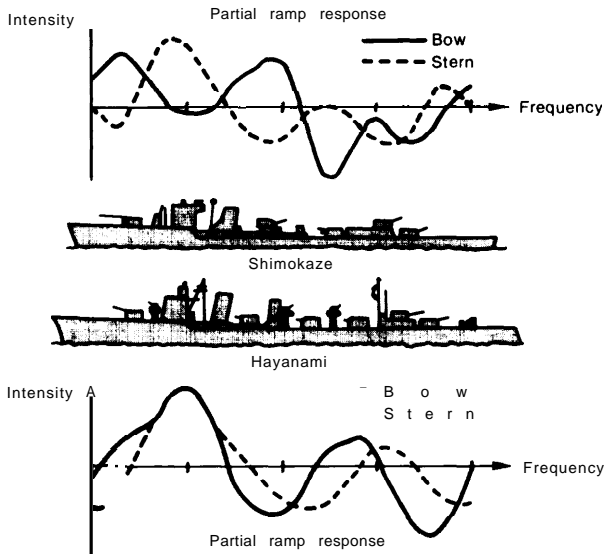
Figure 105 shows the scattered intensity at different frequencies for two similar looking

Figure 104.—Geometry of Over-the-Horizon Radar



SOURCE: Office of Technology Assessment.

**Figure 105.—Radar Cross Sections of Two Similar Looking Ships at Different Over-the-Horizon Radar Frequencies**



SOURCE: E. K. Young and J. D. Walton, Surface Ship Target Classification Using H. F. Radar, Office of Naval Research, Final Report 712352, May 1980.

ships as they might appear to an over-the-horizon radar reflecting off a perfectly smooth undisturbed ionosphere. Although the ships are not resolved in a visual sense, the frequency dependent radar signal differs for each ship. An actual over-the-horizon radar would have to track ships in the presence of traveling ionospheric disturbances and sea clutter.

It is possible that over-the-horizon radars would be able to track and identify ships on the surface of the ocean almost continuously. This identification could be possible if the intensity of reflected radiation at different frequencies, can be measured accurately in the presence of ionospheric disturbances and sea clutter.

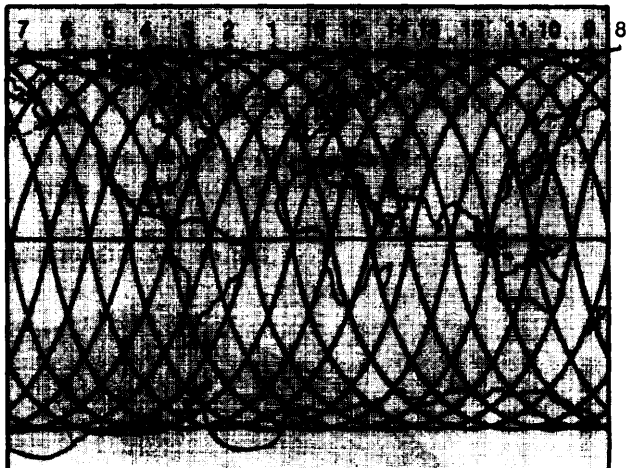
If this promising technology is successfully developed, the *range* of observation is likely to be on the order of 2,000 miles. An over-the-horizon radar would be unlikely to threaten the fleet of MX-carrying ships but could be used to open large areas of ocean to observation from shore-based radars.

## Satellite-Borne Sensors

Satellite-borne sensors could include microwave radiometers (to pick up electromagnetic emissions from ships), infrared sensors, optical sensors, and various types of radars. Figure 106 shows the ground tracks of the Cosmos 749 satellite that has an orbital period of about 95 minutes and an orbit inclined at 74° from the Equator. As the Earth rotates to the east, the ground track of the satellite precesses to the west. Because of the chosen orbital period, the satellite ground tracks repeat themselves every 24 hours (or every 16 orbits).

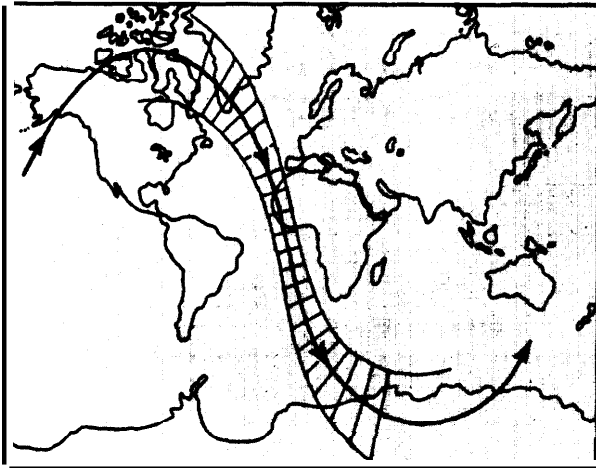
Figure 107 shows the ground swath of the satellite assuming that it has a sensor range of 500 to 600 miles from its ground track. The changing shape of the ground swath is due to the ground swath being drawn on a Mercator projection, with a changing distance scale. Figure 108 shows the orbits for which it overflies the Atlantic. This overflight occurs twice during a 24-hour period of 16 orbits. Figure 109 shows ground swaths of two successive satellite orbits. If the satellite sensors have a range of 800 to 900 miles the satellite swaths would overlap even at the Equator and all the over-

**Figure 106.—Ground Track of Surveillance Satellite in a 24-Hour Period**



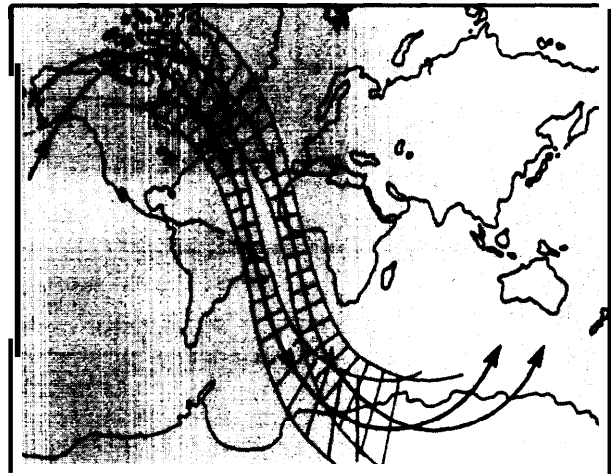
SOURCE: Stockholm International Peace Research Institute Yearbook

Figure 107.—Obse[m]ation Swath of Surveillance Satellite



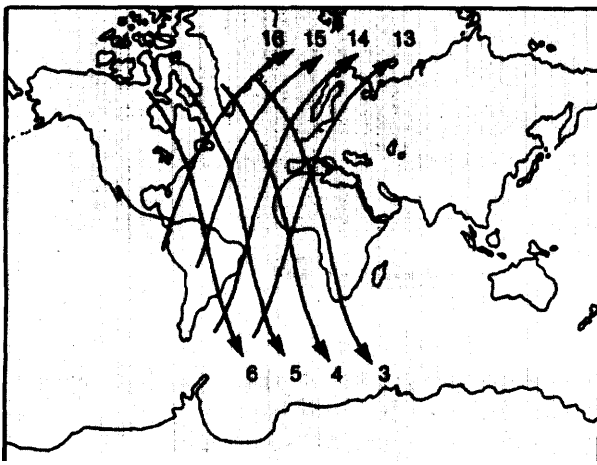
SOURCE: Off Ice of Technology Assessment

Figure 109.—Precession of Observation Swath on Two Successive Orbits of a Surveillance Satellite



SOURCE: Office of Technology Assessment

Figure 108.—Single Satellite Repeat Coverage of Mid-North Atlantic in a 24-Hour Period



SOURCE Off Ice of Technology Assessment

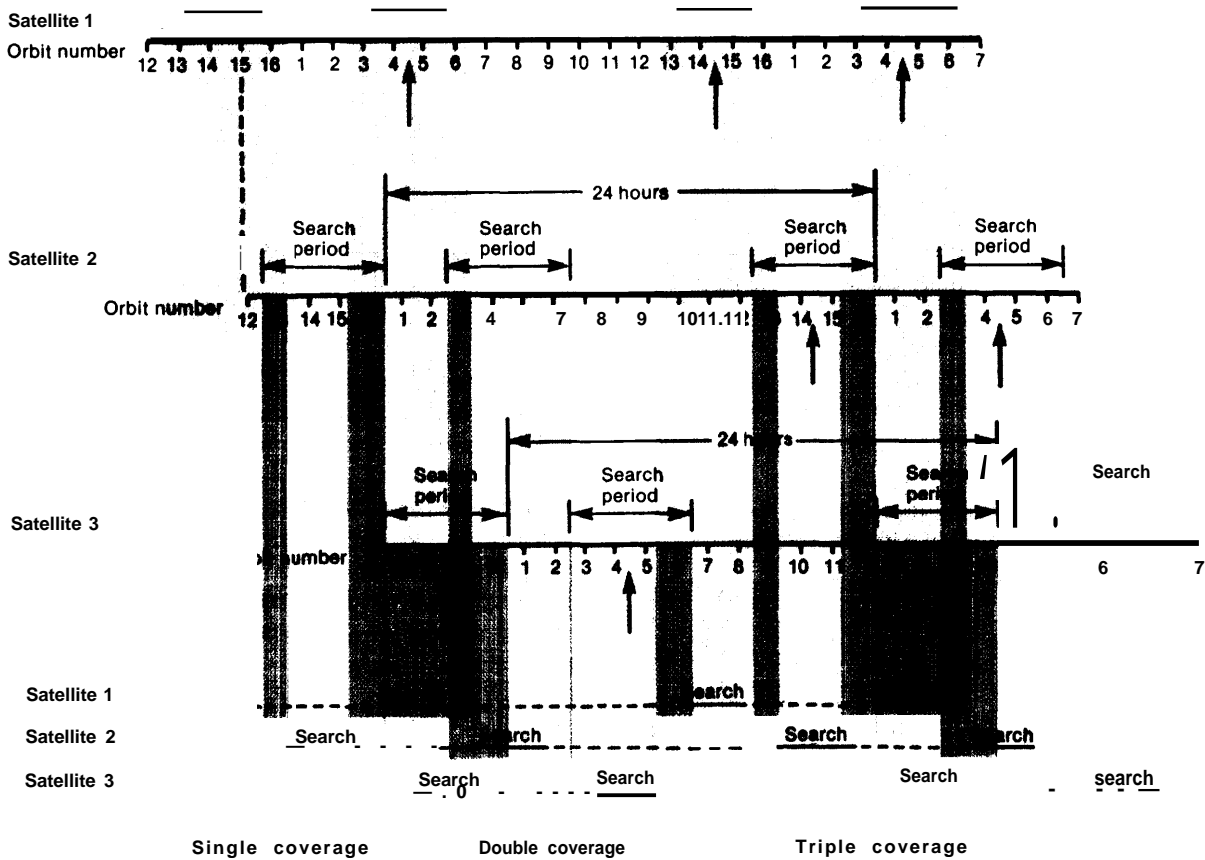
flow[n] regions of the Earth's surface could be covered by a single satellite. If three such satellites were launched in orbits separated by an order of 700 to 800, the surface of the Atlantic would be observed on an average of every 3 to 4 hours (see fig. 110 for details of the satellite overflight schedule). If the range of the sensors did not allow for overlapping observations on successive orbits, more satellites would be needed. A sensor range of 450 nmi

would require 6 satellites and a sensor range of 225 miles would require 12 satellites. This range would allow the Soviets to observe all areas of the world's oceans (with the exception of the region near the North and South Pole) every 3 to 4 hours.

If an extensive system of satellites was used to observe (but not identify) large surface ships while at sea, an operational need might arise for the MX ships to make false reports to shore using standard merchant HF channels. Since owners of merchant ships usually want to remain informed about whether or not their ship is on schedule, merchant ships will usually report their positions to shore based H F stations once a day. If Soviet ships on regular patrol routinely recorded HF messages and reported them back to a central facility, there would be a very high probability that HF messages would be intercepted. These data could then be combined with data collected from published merchant ship sailing schedules and satellite reconnaissance data to help identify ships that might be MX carriers.

Satellites could not only be of use in observing ships on the surface of the ocean but signature data could be accumulated and correlated with observations from surface ships and aircraft. If some form of "fingerprinting" could be accomplished using either radar, infrared,

Figure 110.-Search Schedule of Surveillance Satellites at Mid- Northern Latitudes



SOURCE: Office of Technology Assessment

or passive microwave sensors the ships could be continuously tracked from space. "fingerprinting" was not technically possible, the satellites could be used by trailing ships to help reestablish contact with recently lost sur-

face ships. This use of the satellites would greatly reduce the need to trail at very close distances and would also be an aid to picking up ships after port egress.

## MX REQUIREMENTS AND SURFACE SHIP FLEET

As has been demonstrated in the sections above, major uncertainties would exist with regard to the survivability of a fleet of MX-carrying surface ships. These uncertainties derive from the fact that surface ships are observable at very great distances. As sensing technologies advance, new and novel capabil-

ities for detecting and "fingerprinting" surface ships at great distances can be expected to contribute to surveillance capabilities. Once "fin gerprinted," a surface ship would not have to be resolved in the sense that is usually associated with "seeing" an object, if it is to be successfully tracked. While it can be expected

that tracking capabilities would change with the weather, time of day, and ship operations, it cannot be expected that cover of night or bad weather will dramatically enhance the survivability of such a fleet.

Another aspect affecting the survivability of a fleet of MX-carrying surface ships is the operational circumstances of individual ships. These circumstances would be constantly changing with time. The survivability of some ships may be due to circumstances independent of those of other ships (i. e., some ships may have to transit between bad weather while other ships do not) or may be due to circumstances dependent on those of other ships (a

trailer confronted with two ships, might, for instance, have to choose which ship to trail). The survivability of such a fleet of surface ships is therefore an unpredictably changing variable.

Since the surface ship fleet would have to be sized to allow for ships destroyed in pre-emptive action, and the survivability is a constantly changing unpredictable variable, there is no way to size the fleet for such a contingency. It is therefore important to note that it is *unlikely that the requirement for 100 surviving missiles on station after any enemy action can be met on a continuous basis if MX were deployed on surface ships.*

## ACCURACY OF SURFACE-SHIP-BASED MX

The guidance technology used by surface-ship-based MX would be largely the same as that used for submarines. The accuracy figures discussed below assume the same sets of guidance technologies as those discussed in the chapter on submarines.

Since surface ship survivability requires that the ships operate in as large an area of ocean as possible, many of the ships could be expected to be at a full 6,000-mile range from Soviet targets.

Figure 85 in chapter 5 shows the CEP multiplier v. range for an inertially guided missile and a star-tracker-aided inertially guided missile. The CEP multiplier is a number defined as the CEP of the sea-based missile divided by the CEP design requirements of the land-based MX. Thus, an accuracy multiplier of 1.5 means that the CEP of the missile in question is 1.5 times that of the CEP design requirements of the land-based MX.

As noted in chapter 5, it is expected that the land-based MX will exceed its CEP design requirements, so a CEP multiplier of 1.0 does not necessarily mean accuracy equal to a land-based MX.

Figure 85 is a plot of CEP multiplier at a full 6,000-nmi range for a sea-based MX guided

with purely inertial technology and with inertial technology aided by a star tracker. For pure inertial guidance, at a range of 6,000 nmi the accuracy of the missile would be degraded relative to the accuracy design requirements of the land-based MX. If the advanced inertial measuring unit were aided with a star tracker, the CEP multiplier at 6,000 nmi could be expected to be comparable to the design requirements set for the land-based missile.

If the surface ship fleet were forced to deploy at 6,000-nmi ranges from Soviet targets and the sea-based MX has purely inertial guidance the single-shot kill probability against hard targets would be degraded. However, if the hard targets were to be attacked with two warheads, the double-shot kill probability would still be high.

If a star tracker were added to the inertial guidance system of a sea-based MX, the accuracy would degrade much more slowly with range. In this case, ships deployed at a 6,000-nmi range from targets could have CEPs comparable to the design requirements set for the land-based MX. For this set of circumstances the single-shot kill probabilities would be very large and, correspondingly, the double-shot kill probability would also be very large.

A third system of guidance technologies that might be used would be to enhance the accuracy of the missile by updating the inertial guidance system of the missile with the aid of a system of radio ground beacons or with the GPS. Using this system of guidance, MX accuracy would be achieved against Soviet targets from any point in the deployment area if the GPS were used.

If the GPS was unavailable due to attacks on the satellites, the ground beacons deployed on the coast of the continental United States and the coast of Alaska could be used instead. In order to use the ground beacons, it would be necessary for the ships to deploy to areas within which the missiles could "see" the beacons after launch. These regions are shown in figures 86 and 87 in chapter 5.

## RESPONSIVENESS OF A SURFACE SHIP FORCE

The operational complexity of a surface ship force could make it very difficult for a fleet of MX-carrying surface ships to be responsive to NCA.

A major operational problem that could affect the responsiveness of the force is the low survivability of the ships to preemptive action. It would be necessary for a roll call to be taken in order to be sure that high-priority targets were covered. If ships were still threatened with attack during the process of taking the roll call, high-priority targets would have to be reassigned to still other surviving ships. This reassignment could make the timing of a large coordinated strike extremely difficult to execute.

It is also possible that hostile forces would be unable to attack the remaining ships. This inability could occur if the United States successfully destroyed Soviet surveillance sensors and a significant portion of Soviet Naval forces. Under these conditions, retargeting the ships could be done with a multisynchronous satellite system, that would have the ability to survive Soviet antisatellite attacks. Since the satellites would use extremely high frequency (EHF) channels, the ships could direct transmissions into such a narrow beam that the probability that the ships' transmissions would be intercepted would be very low. The ships could then communicate two ways with NCA at very high data rates and retarget the surviving MX missiles.

A surface ship would have the ability to maintain high accuracy for an indefinite

period of time after antisatellite attacks on GPS if the missile guidance system were based on star tracker enhanced inertial guidance and the ships inertial navigation system utilized advanced guidance technologies. Under these conditions the ship could carry out launch orders against very hard targets without serious delays.

If the missile guidance were purely inertial, missile accuracy would rapidly be degraded as a function of time (in a period of time of tens of hours rather than tens of days). This degradation occurs because the star tracker can be used to help correct for navigational errors which accumulate over time in the ships' navigational system. If the missile does not have a star tracker, errors in the ships' navigational system cannot be compensated for during the early portion of the missile's flight.

Without a star tracker update, the damage expectancies against very hard targets would be significantly degraded over time unless the ships positioned themselves near acoustic transponder fields so they could update their guidance systems. The ships would then have to operate in a manner that could diminish their survivability.

If the missile guidance were based on radio beacon updates of the missile's guidance system, the ships would have to redeploy to the areas shown in figures 86 and 87 in chapter 5. In this case, redeployment activities could delay execution of the force for days and the responsiveness of the system would be poor.

## FLEXIBILITY

If attrition of the force was occurring on a time scale on the order of that required for attacks on targets, flexibility of targeting would be nonexistent.

If the force was not being attritted and there was confidence that ships ordered to carry out attacks would survive long enough to carry out orders, targeting flexibility of the MX-carrying surface ships would be possible. This flexibility would be accomplished using communications channels through the multi synchronous EHF

satellites or simply with VLF transmissions from land-based VLF stations or survivable airborne VLF radio relays. Emergency Action Messages could be transmitted over VLF if pre-planned options or sub-options within pre-planned options are to be executed. Large amounts of data required for ad hoc attacks on targets designated by latitude, longitude, and height of burst would be transmitted over the EHF channels through the multisynchronous satellites.

## ENDURANCE

The endurance of a fleet of surface ships could be very great provided the ships were not under constant attack from sea-based Soviet assets. The ships could have an at-sea endurance in excess of 120 days. Assuming that the ships were at sea for an average of 30 days at the beginning of hostilities, no ships

would have to return to port for at least 90 days. At the end of 90 days, half of the surviving ships would have to return to port and by the end of 120 days surviving ships would either have to be replenished at sea or return to port.

## COST AND SCHEDULE

The surface ship considered for the cost analysis is the SL-7 type fast containership. The specifications of the SL-7 are shown in table 32. It should be noted that this ship was chosen for purposes of costing because it is an existing design of a merchant ship with a very high speed (33 knots). It is unlikely that SL-7S would be a good choice of surface ship because the ratio of its hull length to width would be easily distinguishable from space. It should be noted that the SL-7 has insufficient fuel capacity to stay at sea for more than 26 to 27 days at a 20-knot patrol speed. The ship could be operated at a lower average patrol speed but this would make the endurance requirements on Soviet trailers less severe and would therefore diminish the stress on Soviet forces committed to tracking the ships. Therefore, at a minimum, the ships would have to be modified to carry an additional 5,000 to 6,000 tons of fuel or would have to be refueled at sea.

The lifecycle cost estimate for a fleet of SL-7-type surface ships is presented in table 33.

Initial operational capability would be sometime in 1987, assuming the success-oriented missile development effort is not seriously delayed by the need for guidance system modifications or redesign. This date is determined by the long leadtime needed for the MX missile, not by long leadtime required for the construction of ships. The time estimated for construction of the leadship is on the order of 3 years. The time required for follow-on ships would be on the order of 2 years.

If it turned out to be feasible to home base the ships near the Atlantic strategic weapons facility (SWFLANT) and the Pacific strategic weapons facility (SW FPAC), some costs and construction could be avoided,



Table 32.—SL-7 Specifications

Length overall	946' 1-1/2"
Beam	105' 6"
Draft - design	30'
operating	34'
Propulsion	Geared steam turbines
Shafts	2
Boilers	2
Shaft horsepower (total)	120,000
Depth at main deck (fwd of aft deck house)	64'
Depth at main deck (aft deck house to fantail)	68' 6"
Speed (light draft)	33 + kts
Displacement - 30' draft	43,000 tons
34' draft	50,300 tons
Fuel capacity	4,434 tons
Fuel consumption -33 kts	614 tons/day
25 kts	240 tons/day
19 kts	159 tons/day
12 kts	34 tons/day
Electrical capacity	2 installed, 3,000 kW Ships service turbo generator
	1 installed 1,500 kW Ships service diesel generator
	1 installed, 60 kW Emergency diesel generator

SOURCE J W Noah

It is also possible that ships could operate from other existing naval bases. The feasibility of this approach would be determined by the availability of waterfront area and land near these bases. There would be a need to construct additional waterfront facilities for the ships. These facilities would have to be constructed to satisfy "minimum" safe handling distances for explosive materials. Large amounts of additional real estate would also be required for a missile assembly area and a weapon storage area.

It should be noted that early deployment (i.e., 1987) of a few MX-carrying surface ships would not necessarily result in surviving missiles at sea, as would be the case with submarines. Because surface ships achieve survivability by dispersing in large areas of the

Table 33.—1 O-Year Lifecycle Cost  
(billions, fiscal year 1980 constant \$)

Cost element	Number	cost
<b>RDT&amp;E</b>		
Surface ship	—	\$0.100
Missile	—	6.056
SWS	—	0.400
Capsule	—	0.282
Nav. aids	—	0.190
<b>Total RDT&amp;E</b>		<b>\$7.028</b>
<b>Procurement</b>		
Surface ship	30	\$9.983
Basing	2	4.830
Missile	485	5.578
SWS		2.190
Capsule	5%	1.705
Nav. aids	1 500/3000	1.400
<b>Total procurement</b>		<b>\$25.686</b>
<b>Total acquisition</b>		<b>\$32.714</b>
<b>Operating &amp; support</b>		
IOC to FOC		\$ 1.165'
FOC + 10		8.879
<b>Total operating &amp; support</b>		<b>\$10.044</b>
<b>Total 10-year LCC</b>		<b>\$42.758</b>

\*Note: Ship availability and basing availability are not compatible, therefore interim support ship basing used.

SOURCE Office of Technology Assessment

ocean in an attempt to exhaust Soviet trailing and monitoring capabilities, the first surface ship that goes to sea may face substantial Soviet trailing assets. The survivability of a fleet of surface ships will depend on the ability to spread trailing forces thin enough that it is difficult for a trailer to reacquire the ship if it is lost. A Soviet decision to commit substantial assets to trailing a fleet of surface ships could result in a substantial Soviet trailing capability by the time the first lead ship is deployed. The survivability of the surface ships would only improve as more ships came on line, taxing the capacity of the Soviet trailing fleet and driving the size of the Soviet trailing commitment to substantial levels.

Chapter 8

# LAND MOBILE MX BASING

## Chapter 8.— LAND MOBILE MX BASING

	Page
Barrage Attack on Mobile Systems . . . . .	258
The "Area Kill" Mechanism . . . . .	258
Attack On Mobile Basing Systems . . . . .	260
Land Mobile MX Mx Basing Concepts . . . . .	261
Road Mobile MX: Continuously Dispersed . . . . .	261
Road Mobile MX: Disperse-on-Warning . . . . .	263
Off-Road Mobile MX . . . . .	264
Dash-to-Shelters . . . . .	264
Rail Mobile MX . . . . .	264

### FIGURES

	Page
111, Lethal Radius of One-Megaton Weapon as Function of Vehicle Hardness . . . . .	258
112. Lethal Radius as a Function of Weapon Yield for Various Values of Vehicle Hardness . . . . .	259
113, Barrage Patterns of One 8-Mt Weapon and Seven 430-kT Weapons	259
114. Area Barraged by an ICBM Force of 3,000 EMT as a Function of Vehicle Hardness . . . . .	260
115 Length Barraged by an ICBM Force of 3,000 e-Megaton Reentry Vehicles as a Function of Vehicle Hardness.	260

## LAND MOBILE MX BASING

---

Land mobile MX-basing systems would seek to create uncertainty for the Soviet targeter by constantly changing missile location in an unpredictable way. If the locations of the missile-carrying vehicles were completely unknown to the Soviets, then the only way to attack them would be to barrage or pattern bomb the deployment area, spreading destructive effects over as wide an area as possible. To guarantee survival of a fraction of a land mobile force, the deployment area would have to be larger than the area that the Soviets could “sweep clean” with a barrage. If the Soviets were able to observe the vehicles by remote means and target their attack at individual vehicles on the basis of recent sightings, then the vehicles would have to be fast enough to generate a large uncertainty in their locations in the time elapsed between the last preattack sighting and the arrival of RVS targeted on the basis of that last sighting.

In either case, the Soviets would have to blanket as much area as possible with nuclear effects lethal to the MX-carrying vehicles. The “area kill” mechanism — as opposed to the aimpoint or hard-target kill relevant for missile silos or multiple protective shelters (MPS)— has the important feature of being insensitive to Soviet fractionation. Roughly speaking, the area (or length of road or rail) the Soviets could barrage with nuclear destruction of a given severity would depend on the number and size of Soviet missiles but not on whether the missiles carried a small number of high-yield reentry vehicles (RVS) or a larger number of smaller yield RVS. The small warheads would be more numerous, but each would barrage a smaller area, and the total area covered by all the warheads from a given missile would be roughly the same no matter what the fractionation. Said another way, the vulnerability of a land mobile MX basing system would be sensitive to the total throwweight in the Soviet arsenal but not to how that throwweight was apportioned among RVS.

Because it would be more difficult for the Soviets to increase their throwweight than their number of RVS, the “area kill” vulnerability of Land Mobile systems is attractive in principle. However, it is difficult to realize in practice.

Road mobile MX could either have missile-carrying trucks continuously in motion on the highways (Continuously Dispersed Road Mobile) or stationed at central bases and dispersed onto the highways on warning of Soviet attack (Disperse-on-Warning Road Mobile). Off-Road Mobile could either have hardened vehicles moving randomly throughout a large area or dashing from central bases to dispersed hardened shelters. Rail Mobile MX would travel the Nation’s railways.

None of the land mobile concepts turns out to be a particularly attractive option for MX-missile basing, but Continuously Dispersed Road Mobile could be highly survivable, and its survivability would be independent of warning. Disperse-on-Warning systems would require hours of warning time if they were to survive attack, so they would always be vulnerable to surprise. Off-Road Mobile would require a very large deployment area. Dash-to-Shelters would use a smaller amount of land than Off-Road Mobile but would still depend on warning. In fact, MPS basing with preservation of location uncertainty (PLU) could be viewed as an evolution of Dash-to-Shelters with dash reemphasized to achieve independence from warning. Rail Mobile would suffer from the need for right-of-way on intercity lines.

In addition to problems with the fundamental concepts, land vehicles capable of carrying the 190,000-lb MX missile would be very large. A road vehicle would probably be much too large to fit under highway underpasses and too heavy to cross highway bridges. Thus, Road Mobile MX is probably a practical impossibility. Off-road vehicles of MX size could be very destructive of their deployment areas.

## BARRAGE ATTACK ON MOBILE SYSTEMS

This section discusses some basic features of nuclear barrage attacks, the type of attacks relevant to basing systems consisting of mobile missile-carrying vehicles. In contrast to the survivability of systems of fixed hard aimpoints like silos and MPS, which depends on the number, yield, and accuracy of Soviet RVS, the survivability of mobile systems depends on the total equivalent megatonnage (EMT) in the Soviet missile force. EMT in turn depends on the size and number of Soviet offensive missiles but is insensitive to whether a given missile carries a small number of high-yield warheads or a larger number of smaller yield warheads. That is, the Soviets would obtain little advantage by fractionating their ICBM missiles with large numbers of multiple independently targeted RVS if the United States were to deploy a mobile basing system. RV accuracy would also be irrelevant, since for soft targets it would be sufficient for an RV to detonate a few miles away (rather than a fraction of a mile, as with silos and MPS) in order to destroy the missile-carrying vehicle. Since mobile basing would deprive the Soviets of any substantial advantage from modernizing their ICBM force, the concept is very appealing. Unfortunately, it is difficult to translate this hypothetical concept into a survivable basing system, principally because the Soviets already possess sufficient EMT in their ICBM arsenal to destroy mobile vehicles dispersed over even very large areas of the United States.

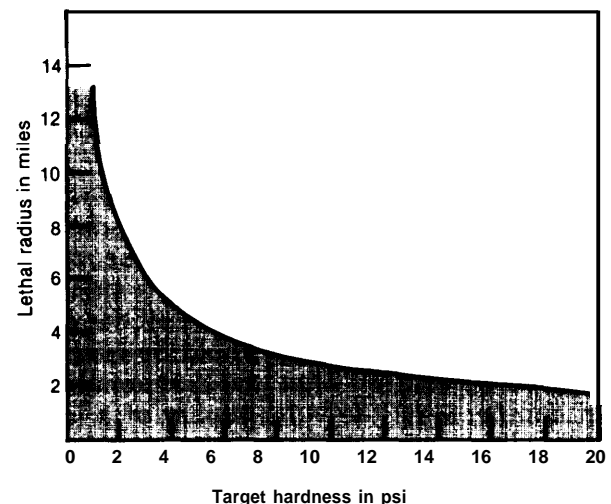
### The "Area Kill" Mechanism

The distance from a nuclear detonation at which a mobile vehicle could survive depends on the vehicle's "hardness," or resilience to nuclear effects, and on the weapon yield. Hardness is typically quoted in pounds per square inch (psi) of static overpressure. This convention does not necessarily imply that static overpressure is actually the effect that destroys the vehicle or renders it inoperable: gusting winds that follow the shock front ("dynamic overpressures"), thermal radiation, or other effects might be responsible for vehicle

impairment. Rather, stating that a vehicle has a hardness of so many pounds per square inch means that it can survive the effects of a weapon at distances from the detonation at which the shock front applies that many psi overpressure. Within the range at which the given overpressure occurs, the vehicle is assumed destroyed; beyond that range, it is assumed to survive. (In practice there is no distance beyond which all vehicles would survive with 100-percent certainty. Instead, there is a "sure-safe" distance, a "sure-kill" distance, and a certain probability of kill at distances between. Also, if overpressure is not the kill mechanism, the "hardness" will actually be a function of yield.)

Figure 111 shows the range to which a given overpressure extends as a function of overpressure for a 1-MT weapon (ground ranges from ground zero for optimum burst height). This is the same as a plot of the "lethal radius" for a vehicle v. the vehicle's hardness. For instance, a 5-psi hard vehicle would be destroyed at a range of 4 miles or closer, an 8-psi vehicle at a range of 3 miles or closer, and so on.

**Figure 11 I.—Lethal Radius of One-Megaton Weapon as a Function of Vehicle Hardness**



SOURCE: Office of Technology Assessment.

For intermediate overpressures, the laws of hydrodynamics prescribe a rough scaling law saying that, for a given hardness, the lethal radius increases as the one-third power of the yield. Figure 112 shows lethal radius as a function of yield for various values of hardness.

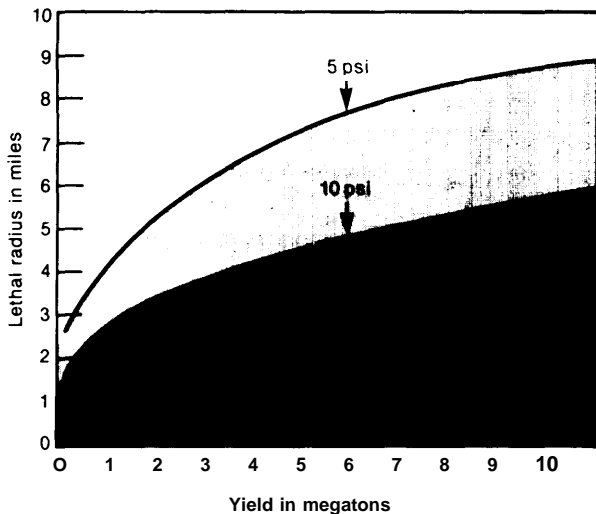
if a vehicle is within a circle of radius equal to its lethal radius, it will be destroyed. The area of this circle is "pi" (3.14) times the square of the lethal radius. Since the lethal radius varies as the one-third power of the yield, the lethal area varies as the two-thirds power of the yield. Since the area that can be "barraged" with a given overpressure is proportional to (yield)<sup>2/3</sup>, the area that can be barraged by a given force of nuclear weapons is proportional to the number of weapons times the two-thirds power of their yield. This quantity is called the EMT of the force:

$$\text{Barrage area proportional to EMT} = (\text{number of weapons}) \times (\text{yield})^{2/3}$$

where the yield is measured in megatons. Thus, a force of 4,000 1-MT RVS has 4,000 EMT, and a force of 1,000 8-MT RVS also has 4,000 EMT.

Since mobile basing systems seek survivability by dispersing over wide areas, their sur-

**Figure 112.—Lethal Radius as a Function of Weapon Yield for Various Values of Vehicle Hardness**



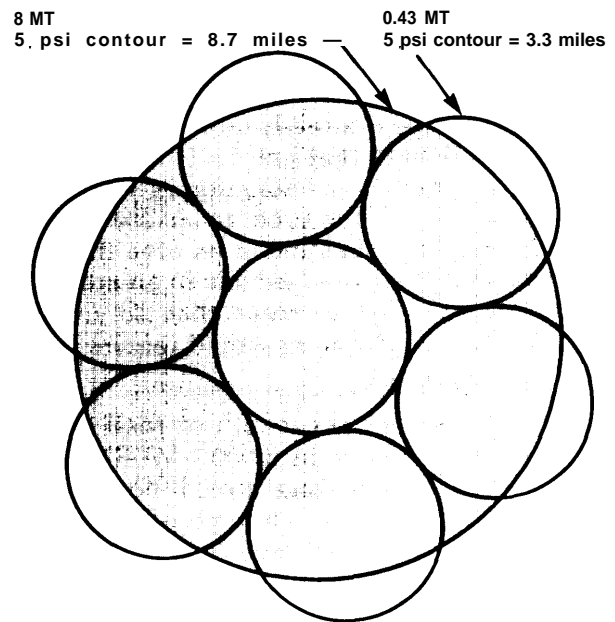
SOURCE Office of Technology Assessment

vivability depends on how much of the deployment area can be barraged by the Soviets, which in turn depends on the total EMT in the Soviet ICBM force.

It so happens that the EMT that can be delivered by a given ICBM depends (speaking roughly) only on its throwweight and not on how this throwweight is apportioned among RVS. The effectiveness of a given missile in barraging an area is relatively insensitive to payload fractionation. The missile can carry a small number of high-yield RVS or a larger number of smaller yield RVS. The smaller RVS would be more numerous, but each would barrage a smaller area. The total barrage area would be about the same no matter what the fractionation.

Figure 113 shows the barrage patterns of a single 8-MT RV (4 EMT) and of seven 430-kil -

**Figure 113.—Barrage Patterns of One 8-MT Weapon (4 EMT) and Seven 430.kT Weapons (also 4 EMT)**



One 8-MT weapon = 4 EMT  
Seven 0.43-MT weapons = 4 EMT

The area covered is about the same no matter how the EMT is apportioned among reentry vehicles

SOURCE. Office of Technology Assessment

oton RVS (also 4 EMT). The circles show the areas within which a 5-psi vehicle would be destroyed. The barrage area is about the same no matter what the "fractionation."

In summary: In contrast to a system of hard point targets (silos or MPS), the survivability of a mobile system which the Soviets had to barrage would depend on the EMT of the Soviet missile force but would be relatively insensitive to the fractionation of each missile. Therefore, to substantially increase the threat to a U.S. basing system subject to area barrage, the Soviets would have to build more missiles. To increase the threat to silos or MPS, they would need only to increase the number of RVS carried by existing missiles. Furthermore, since the lethal radius is a few miles for the overpressures relevant to mobile basing, differences in RV accuracy of a fraction of a mile are irrelevant to the area kill mechanism. Thus, for purposes of attack on a mobile basing system, Soviet accuracy improvements would gain them little.

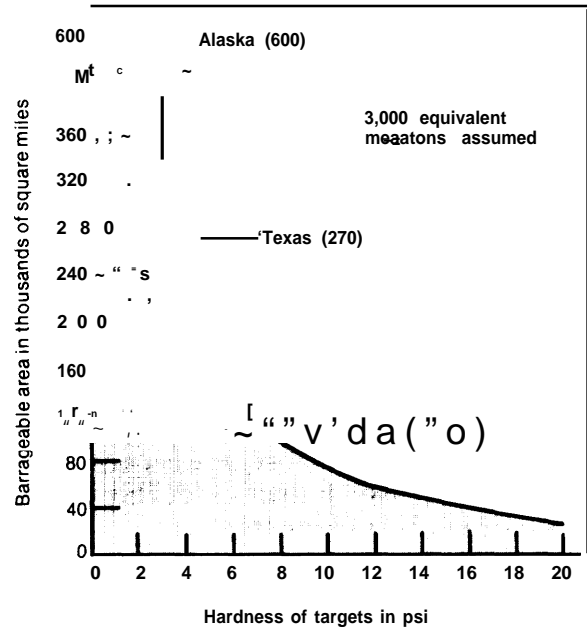
Because their survivability would be insensitive to fractionation and accuracy, mobile basing systems are attractive in principle. However, the area the present Soviet ICBM force can barrage is already quite large. Figure 114 shows the area that can be barraged by a force of 3,000 EMT as a function of hardness. The figure shows that such an arsenal could destroy every 4-psi vehicle in an area the size of Texas and every 7-psi vehicle in an area the size of Nevada. It is clear that survivable mobile MX-basing systems would require large deployment areas.

Figure 115 shows the length of road or rail that could be barraged by 3,000 1-MT RVS. Barrage length, unlike barrage area, is not proportional to EMT, but the outcome of a barrage attack on a road or rail mobile basing system would also be relatively insensitive to fractionation. Such an arsenal could also destroy all vehicles on long stretches of road or rail.

### Attack On Mobile Basing Systems

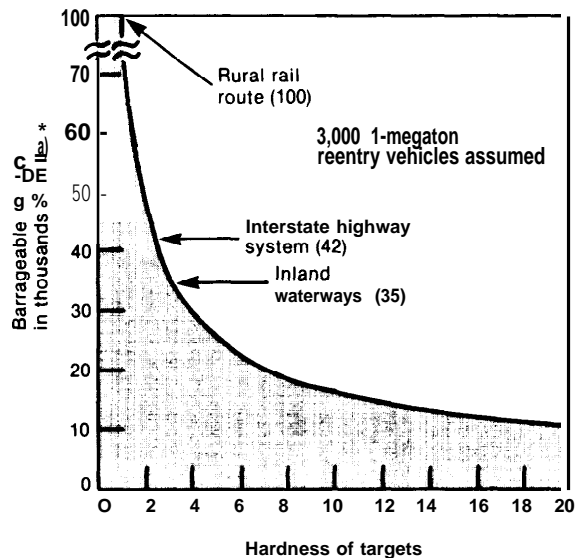
The outcome of an attack on a mobile basing system would depend on whether the Sovi-

**Figure 114.—Area Barraged by an ICBM Force of 3,000 EMT as a Function of Vehicle Hardness**



SOURCE Office of Technology Assessment.

**Figure 115.—Length Barraged by an ICBM Force of 3,000 One-Megaton Reentry Vehicles as a Function of Vehicle Hardness**



SOURCE: Office of Technology Assessment.

ets knew where the individual vehicles were at the time of attack in addition to depending on the total EMT in the Soviet arsenal.

If the Soviets did not or could not track individual vehicles as they moved about the deployment area, they would have to barrage as large a fraction of the deployment area as possible. If the deployment area were twice as large as the area the Soviets could barrage, half of the MX force would survive; if the deployment area were three times as large as the barrage area, two-thirds of the force would survive; and so on.

If the vehicles were stationed at fixed bases and dispersed only when attack was imminent, the Soviets would only have to barrage the vicinity of the bases. For instance, if the vehicles dispersed in all directions when warned of Soviet ICBM launch, and if the vehicles were capable of speeds of 50 mph, then in the half-hour flight time of Soviet ICBMs they would be dispersed within a circle of radius 25 miles from the base. Since this circle would have an area of only 2,000 mi<sup>2</sup>, it would be easily barraged. Therefore, because of the slow speeds of land vehicles, Disperse-on-Warning Road Mobile systems would be vulnerable to surprise attack.

Even a continuously dispersed system could be vulnerable if the Soviets were able to track the vehicles continuously and retarget their missiles on the basis of up-to-the-minute in-

formation. Then they would only have to barrage the vicinity of each vehicle, not the whole deployment area. The time it took the Soviets to determine the location of each vehicle, transmit the locations to their missile fields, program their missiles, and launch them, plus the half-hour ICBM flight time, is called the "intelligence cycle time" (ICT). ICT is thus the time from last sighting to attack arrival. The important quantity in this case is the distance the vehicles could move during the ICT. For instance, if a hypothetical Soviet surveillance system and ICBM force were capable of a 2-hour ICT (and this example by no means intends to suggest that such an ICT is feasible for the present Soviet force), then the vehicles would have two hours to move away from the point where they were at the time they were last sighted (this time would be chosen by the attacker and would be unknown to the U.S. force). If the vehicles patrolled in such a way that they constantly changed direction, moving away from their starting point with *average* speed of 40 mph, then when the Soviet attack arrived they could be anywhere within a circle of radius 80 miles. This circle would have an area of 20,000 mi<sup>2</sup>.

If the Soviet surveillance system were such that it could not locate the vehicles precisely, but only localize them within a circle of radius 20 miles, then a 2-hour ICT and 40 mph average speed would result in a "circle of uncertainty" of radius 100 miles and area 31,000 mi<sup>2</sup>.

## LAND MOBILE MX BASING CONCEPTS

### Road Mobile MX: Continuously Dispersed

A system of missile-carrying road vehicles in continuous motion on the Nation's highways would be survivable if the Soviets were unable to keep track of the location of each vehicle. This section first analyzes Road Mobile as a concept and then describes the special problems which arise when the concept is applied to a very large missile like the MX.

### Road Mobile Concept

Each missile-carrying vehicle would travel in a convoy of perhaps five vehicles with a total crew of 10 to 12 people. The other vehicles would carry security equipment to defend the nuclear weapons against terrorism, sabotage, etc., and communications equipment to keep them in continuous contact with commanders. One hundred convoys, each consisting of two missile-carrying vehicles, two security vans,



and one communications van, might be required for a deployment of 200 MX missiles.

The U.S. Interstate Highway System consists of 42,500 miles of 4-lane highway, not all of which is open to traffic. In addition, there are 81,000 miles of other 4-lane highway, of which 28,000 miles are located near heavily populated urban areas. About 80,000 miles of 4-lane highway located away from populated areas might be available for Road Mobile MX operations.

#### Survivability

Little of a definite nature is known about the effects of nuclear weapons on road vehicles, but there is agreement that a hardness rating of 15 psi is probably an absolute upper limit, with a more reasonable hardness range being 5 to 10 psi. The principal mechanism of destruction might be overturning of the vehicle by the high winds that follow the shock wave from a nuclear detonation. To alleviate this problem, one could put stakes in the ground and lash the vehicle down shortly before attacking RVS arrived. Other problems for road vehicles might be thermal flash and radiation doses suffered by the crews.

A I-MT weapon would destroy a 10-psi vehicle if it exploded closer than about 3 miles from the vehicle. One thousand I-MT weapons could therefore destroy every 10-psi vehicle on a stretch of road 6,000 miles long. To "sweep clean" the entire 80,000 miles of available U.S. highway would therefore require 13,000 I-MT RVS, which is much more than the present arsenal of Soviet ICBMS is capable of delivering. If the vehicles were 5 psi hard, only 9,000 I-MT would be required; if 15 psi hard, then 18,000 I-MT would be required.

It is important to recall that what matters in these barrage attacks is, roughly speaking, the number of attacking missiles, not the number of RVS they carry. (Barrage length, not barrage area, is relevant here; barrage length does not correlate with EMT, but the results are still relatively insensitive to fractionation.) Thus,

for example, a Soviet SS-18 can "sweep clean" about the same length of road whether it carries a few high-yield RVS or a larger number of lower yield RVS. Thus, the survivability of Road Mobile would be insensitive to Soviet fractionation.

A barrage attack on the entire U.S. highway system could cause significant damage to population and industry even if the attack excluded highways in the immediate vicinity of large cities. Road Mobile deployment could therefore conceivably deter the Soviets from attacking U.S. missiles for fear of U.S. retaliation on Soviet population and industry. On the other hand, if a "counterforce" war did begin, the damage to the United States could be considerable.

A theoretical possibility for Soviet attack planners would be to keep track continuously off the locations of the Road Mobile convoys and retarget their missiles on an up-to-the-minute basis. Since the average speed of a convoy might be 40 mph, each convoy could travel no more than 20 miles in the minimum possible ICT of a half hour. If the Soviets were capable of this ideal ICT, they would only have to barrage 2,000 miles of highway to destroy all 100 convoys. For this attack, 330 I-MT RVS would suffice. If the ICT were 1 hour, 660 RVS would suffice, and so on.

Cloud cover over the United States and U.S. countermeasures would make reliance on space-based surveillance a risky course for the Soviets. Human agents capable of tracking the convoys or attacking them directly would also be a possibility.

#### Advantages and Disadvantages

In summary, the principal advantages of the Road Mobile concept are its high survivability in the absence of continuous tracking, the insensitivity of its survivability to Soviet fractionation, independence from warning, little environmental impact, and — at least from some points of view on deterrence — an unclear distinction between attack on U.S. strategic forces and attack on U.S. value.

<sup>1</sup> U S Federal Highway Administration, *Highway Statistics*,

A principal disadvantage of Road Mobile would be the exposure of nuclear weapons traveling the Nation's highways to accidents, public interference, sabotage, and terrorism. Though probably difficult to implement in practice, and subject to U.S. countermeasures, a system for continuous tracking and targeting of Road Mobile convoys would allow the Soviets to destroy a Road Mobile force. Finally, attack on Road Mobile could, depending on the highways used, cause substantial collateral damage to U.S. population and industry.

Minimizing accuracy degradation relative to that planned for fixed land-based deployment might require pre-surveying of thousands of launch points along the nation's highways or provision of external navigation aids.

#### The Problem of Missile Size

The discussion so far has been confined to the concept of Road Mobile missile basing. The problems of actually implementing this concept with the large MX missile would be severe. The vehicle needed to carry MX would exceed by large margins not only the legally permitted loads on the Nation's highways but quite probably the physical tolerances of bridges and underpasses.

According to a rough rule of thumb for design of heavy road vehicles, the gross weight of a loaded vehicle is about twice the weight of the load. The MX missile and its support and launch equipment might weigh 250,000 to 300,000 lb, meaning a 500,000- to 600,000-lb Road Mobile vehicle. To distribute this weight, even with modern independent suspension, could require some 20 axles with 8 wheels each, spaced 8ft apart for a total vehicle length of some 160 ft. By contrast, the maximum load permitted by any State, even with a special permit, is only 100,000 lb, and large tractor-trailers weigh half this amount. The largest load ever moved long distance over the Nation's highways weighed only 335,000 lb and traveled only in good weather. <sup>7</sup>Since the weight of an MX carrier would exceed by large margins the loads for which highway over-

passes and bridges are designed, it cannot be said with assurance that these structures could support them.

Size of the vehicle would also be a problem. A large beam under the bed of the vehicle would be needed to support the heavy load. Vertical clearance on Interstate Highway underpasses is nominally 16 ft, but many older segments of the system have only a 14-ft clearance. A Road Mobile MX vehicle would probably be too tall to fit under these underpasses.

Thus, the large size of the MX missile makes Road Mobile MX a practical impossibility.

### Road Mobile MX: Disperse-on-Warning

An alternative to keeping missile-carrying vehicles in continuous motion would be to base them at existing military installations and have them disperse onto the highways when given warning of Soviet attack.

For an average vehicle escape speed of 40 mph given tactical warning only, the vehicles could be at most 20 miles from their bases when Soviet RVS arrived. The Soviets would therefore only have to barrage the highways within a 20-mile radius of each base to destroy all the vehicles. If the vehicles were 10 psi hard, then a few tens of I-MT RVS would suffice for this barrage.

If the vehicles were given more warning time, then they could disperse over more road. With about 6 hours of warning time, the vehicles could be dispersed over so much road that a Soviet barrage could not destroy all of them. Disperse-on-Warning Road Mobile would therefore require hours of warning time to survive. If attack were to come with little or no advance warning, the force would be destroyed.

Even given ample advance or "strategic" warning of imminent Soviet attack, there could be concern for the reaction of the U.S. public and the Soviet Union to dispersal of the vehicles from their bases. Thus, there might be inhibitions on the part of U.S. authorities to disperse the force until the evidence of imminent Soviet attack was absolutely convincing.

<sup>7</sup> ~ *Transportation Engineer Magazine*, February 1980

By then it could be too late to guarantee survival of the force.

Traffic might also impede the escape of a Disperse-on-Warning force.

Last, the same problems of missile size would obtain as for Continuously Dispersed Road Mobile.

### Off-Road Mobile MX

Off-Road Mobile would be a system of wheeled, tracked, or ground-effect vehicles capable of travelling over relatively rugged terrain. By dispersing over a large area and following random paths, such a system would force the Soviets to barrage the entire deployment area to destroy the missiles. The success of such a barrage attack would be insensitive to Soviet fractionation.

Off-Road Mobile would require a large amount of land for deployment, and the random movement of the large, heavy vehicles would make off-road operation destructive of the deployment area. If the vehicles were 15 psi hard (a quite high value), then a single I-MT RV could destroy every vehicle in a 16-mi<sup>2</sup> area about the detonation point. Three thousand RVS could destroy every vehicle in a 48,000-mi<sup>2</sup> area. To guarantee 50-percent survival of an MX force against such an attack, a total deployment area of 96,000 mi<sup>2</sup> would therefore be required. **If the vehicles** were only 10 psi hard, then 150,000 mi<sup>2</sup> would be needed.

For comparison, the area of the State of Utah is 85,000 mi<sup>2</sup>, of Texas 267,000 mi<sup>2</sup>, and of Alaska 590,000 mi<sup>2</sup>. The total amount of land owned by the Departments of Defense and Energy in the Southwest (including Nellis Bombing and Gunnery Range, Yuma Proving Ground, White Sands Missile Range, and Fort Bliss Military Reservation) is about 17,000 mi<sup>2</sup>.

An Off-Road system that did not occupy the entire dispersal area at all times, but flushed from central operating bases on warning, would be vulnerable to surprise attack in the same manner as Disperse-on-Warning Road Mobile. The consequences of false alarm dispersal could be serious if the dispersal area

were normally used for peaceful purposes, since the vehicles would be quite destructive of the terrain.

As in the case of Road Mobile, design of vehicles to carry the large MX missile safely over rough terrain would be challenging.

### Dash-to-Shelters

A large dispersal area would be required for Off-Road Mobile because the vehicles would be relatively soft targets, of order 10 to 15 psi. The deployment area could be contracted by providing many harder garages or shelters throughout the deployment area. The vehicles would take refuge in the shelters shortly before attacking warheads arrived. Such a system would in fact be a multiple aimpoint system, since the Soviets would target each shelter individually rather than bombard the whole area.

The Dash-to-Shelters concept can be seen as a precursor of the MPS system with PLU such as presently under development by the Air Force. A Dash-to-Shelters system would force the Soviets to target all the shelters, since the missile transporter would not choose which shelter to dash to until it received warning that a Soviet attack was underway. Success of this system would therefore depend upon reliable warning. The same objective of forcing the Soviets to attack each shelter could be attained, and the dependence on warning removed, by emplacing the missiles in the shelters before the attack but concealing which shelter actually received the missile. This approach would of course be the MPS concept with PLU.

### Rail Mobile MX

Rail vehicles to carry the large MX missile could probably be built much more easily than large wheeled vehicles. Like road vehicles, the rail cars would be vulnerable to overturning by the strong winds that follow a nuclear blast wave. The hardness of a rail vehicle would therefore be in the region of 10 psi, though lashing down the vehicle might result in

greater hardness. A I-MT RV could therefore “sweep clean” some 6 miles of rail.

There are about 200,000 miles of rail *route* in the United States. The length of track is larger, since many routes consist of several parallel tracks. Many of these rail routes are in the **vicinity of large population concentrations, so a smaller length of route— perhaps 100,000 miles—would be available to a Rail Mobile MX force. This is** more track than could be bargaged by any foreseeable Soviet arsenal.

The rail vehicles would have to have right-of-way on the tracks, since their survival would

depend on their ability to choose their itineraries randomly. Since most intercity rail routes such as those that would be used for the missile force consist of only one track, they are already quite congested. Trains must be routed into sidings to allow others to pass, and so on. Military commanders would therefore be dependent on civilian rail operators and workers for the day-to-day operations of the force.

Rail Mobile missiles would also be subject to accidents, sabotage, and terrorism.

Chapter 9

# DEEP UNDERGROUND BASING

# Chapter 9.— DEEP UNDERGROUND BASING

## LIST of figures FIGURES

<b>figure No.</b>		<i>Page</i>
<b>116 Postattack Egress</b>	.....	269
<b>117, Mesa/Tunnel Concept Section View</b>	.....	270
<b>118 Tunnel Boring Machine</b>	.....	271
<b>119. Aerial View of Mesa-[ la Base force</b>	.....	272
<b>120 Mesa/Tunnel Concept Plan View Schematic</b>	.....	272
<b>121. Transporter Launcher...</b>	.....	273
<b>122 Missile Launch</b>	.....	273
<b>123 [and Area Requirements irRequirements</b>	.....	274

## DEEP UNDERGROUND BASING

the deployment of the missile force in deep mountain in tunnels, buried thousands of feet under the surface, thereby providing protection for the missiles from a nuclear attack. Such a facility would be manned and would have self-contained provisions for electrical power, life-support, and missile maintenance. Upon the command to launch, tunnels would need to be bored to the surface to give the missile outside access preparatory to being launched.

The limitations of such a missile deployment derive not from the technical feasibility of its construction, but from the time constraints of a reliable missile egress for launch. A schematic for two types of missile egress is illustrated in figure 116A and B shows a number of completed vertical exit passages that are preconstructed. Missile egress through these passages could be rapid, but the exit portals could be easily attacked with nuclear weap-

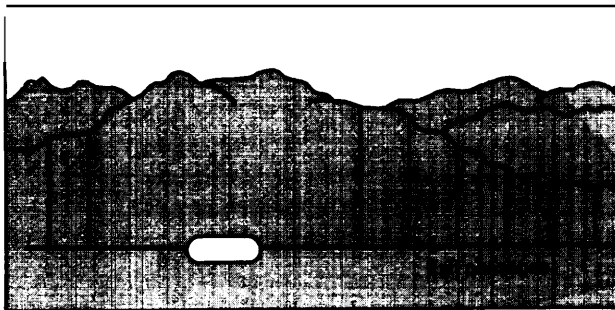
ens, which would deny them the ability to launch the missile. Even "hardened" exit portals would be vulnerable with today's missile accuracies. Moreover, attempts at constructing hidden exits would rely totally on keeping their locations secret for the entire course of deployment - a considerable risk.

These observations have led to designs for deep underground basing without **preconstructed** exits (see fig. 116B). After the order to launch, large underground tunnel boring machines would clear a path to the surface from the partially completed tunnels. This method of launch would not be rapid, due to the lengthy excavation process, and could take a period of days to perhaps weeks; **in the meantime** work continues on devising a faster method for missile egress.

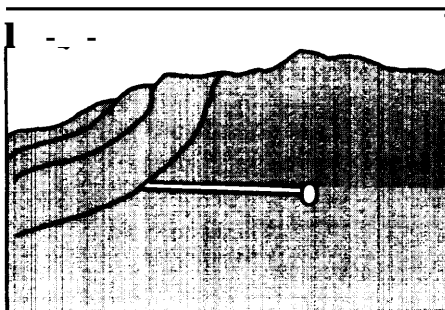
Clearly, this mode would not be suitable as a quick-response force for time-urgent missions after the initial attack - a major stated requirement for the MX missile. On the other hand, it could play a useful part in the overall strategic nuclear force as a secure reserve force. Post-attack endurance might be very good, perhaps a year or longer. Furthermore, it could have a stabilizing effect and serve as a deterrent to war due to its high survivability to nuclear attack. Unlike fixed missile silos or multiple protective shelters, deep underground basing would be relatively insensitive to the increased accuracy of enemy missiles, or the fractionation of their payload. Moreover, deceptive basing of the missiles would be unnecessary.

Although studies of deep missile basing date back many decades, it is still in a conceptual stage. Hardware specific to this type of missile basing has not been developed or tested, although many of its components, such as deep underground facilities and tunnel boring machines, have been constructed for other purposes. And, although a large data base on underground nuclear explosions has been collected over several decades, there is still a

Figure 116A. —Postattack Egress



116B



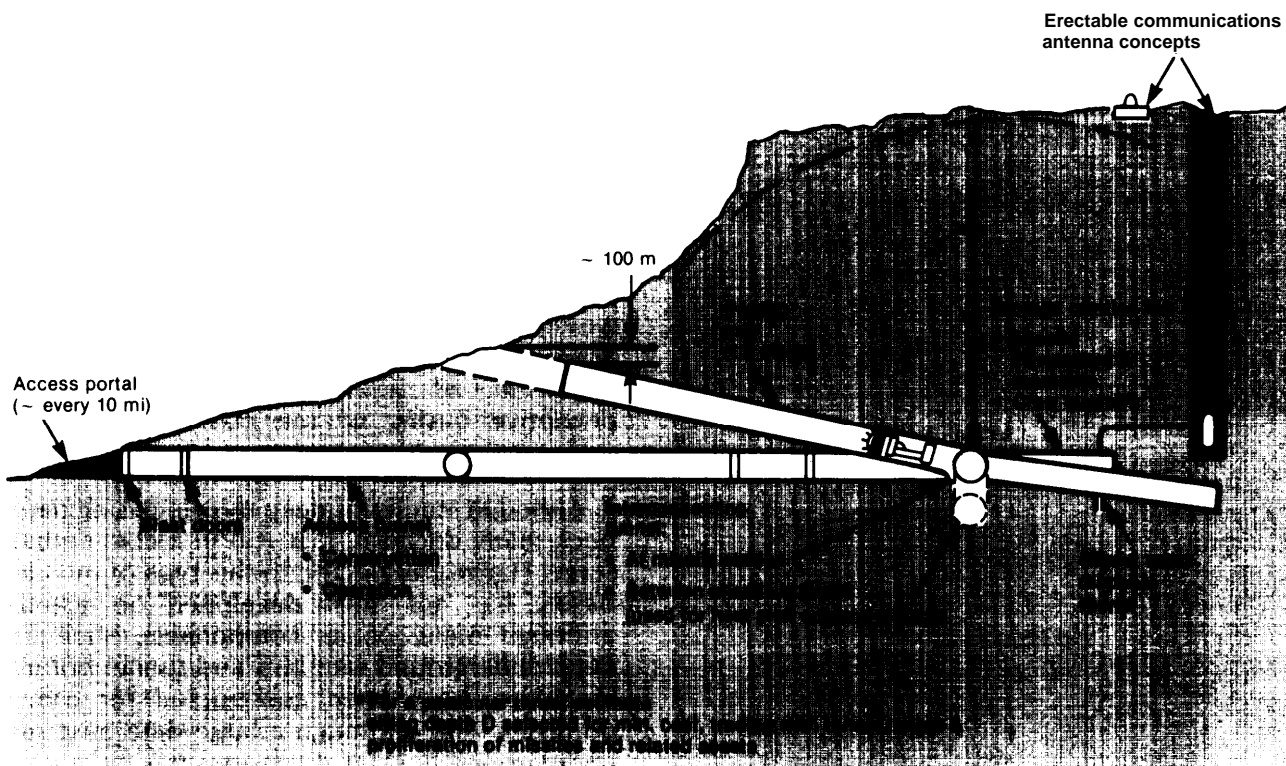
SOURCE: Office of Technology Assessment

degree of uncertainty on the coupling of explosive energy of a nuclear surface burst to the underground. This knowledge would be important in determining the minimum tunnel depth for sure survival of the missile against a large nuclear attack.

One concept for deep basing is illustrated in figure 117. This approach would utilize basing inside of a mesa, which, due to its relatively steep slope, has the advantage of providing a short tunneling length to the mesa face for missile egress. System burial would be typically several thousand feet. The exit route for the missile would be partially predug, with the remainder left to be dug by a tunnel boring machine, after receiving the command to launch. In addition, a number of horizontal access tunnels would lead to the underground complex from the outside. These access tunnels, which would be required during construction,

would also provide underground access during peacetime. Blast doors in these tunnels would be needed for protection of the underground complex during an attack. Storage cavities would be provided for crew quarters, a fuel cell powerplant and its reactants, waste disposal, and tunnel boring machines. (A typical tunnel boring machine is shown in fig, 118. It is constructed and sold for tunneling operations.) A reliable means of assuring a survivable communications link between the outside and the missile force has not yet been fully developed, although a number of possible candidate concepts do exist. One such concept involves the deployment of a large number of erectable communications antennas, as illustrated in the diagram. Assuring continuity of this link through the mesa during periods of attack is still a matter to be fully resolved, since resulting block movements inside the mesa may break underground cable links.

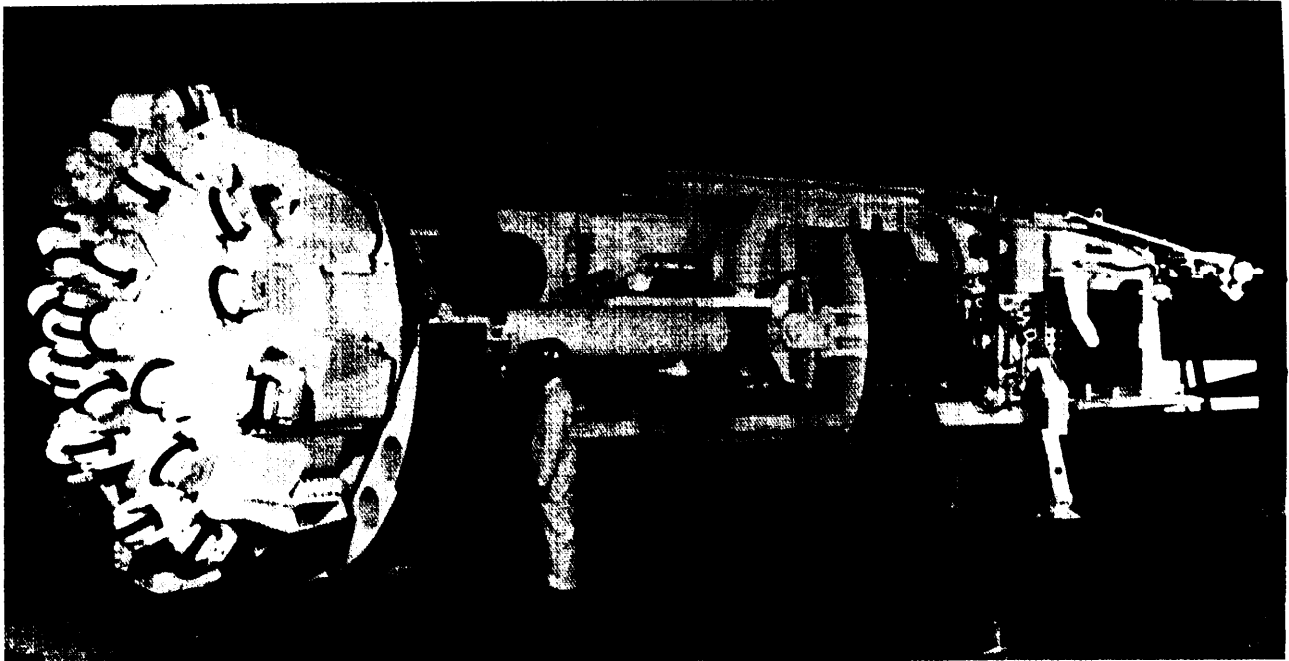
Figure 11 7.—Mesa/Tunnel Concept Section View (not to scale)



SOURCE: Office of Technology Assessment



Figure 118.—Tunnel Boring Machine



SOURCE: Robbins Co., Seattle, Wash.

An aerial view of the underground mesa-based force is shown in figure 119. The underground tunnels, shown as broken lines, form a closed complex around the mesa. An enlargement of a tunnel section is described in figure 120. The missile would be part of a launcher and transporter vehicle, as shown in figure 121, that resembles the vehicle used for buried trench basing, as discussed in chapter 2. For missile launch, after the tunnel boring machine cleared the way to the surface, the transporter-missile-launcher would move through the newly built tunnel to the surface, under its own power. This is illustrated in figure 122.

OTA has not analyzed either the environmental impacts or scheduling considerations for deep basing. A preliminary review does not indicate the likelihood of insurmountable problems, however. Estimates for system cost

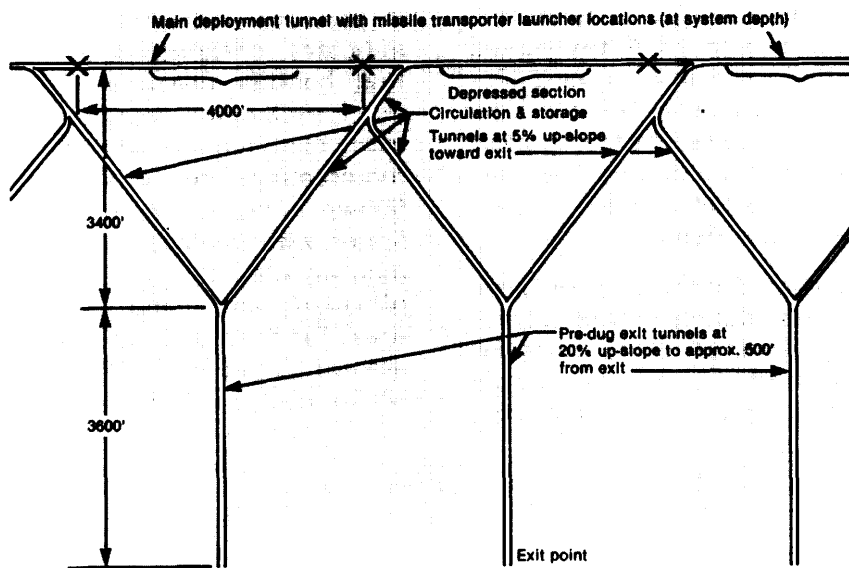
and construction time are highly tentative at this time. Much work on the detailed concept (particularly C<sup>3</sup>), research and development, and validation of design would be needed. Moreover, delays in construction for this basing mode could be expected, as experience in previous underground excavation projects indicates unexpected geological conditions that hamper progress. On the other hand, much excavation experience is available from many commercial and civil projects. Land area requirements are likely to be relatively small. Shown in figure 123 is a map of the United States with deployment areas of the Minuteman missile fields, the proposed MX/MPS deployment area, and two candidate basing areas for deep underground basing, one in the area of Grand Mesa, Colo., and an alternative site in southern Utah.

Figure 119.—Aerial View of Mesa-Based Force



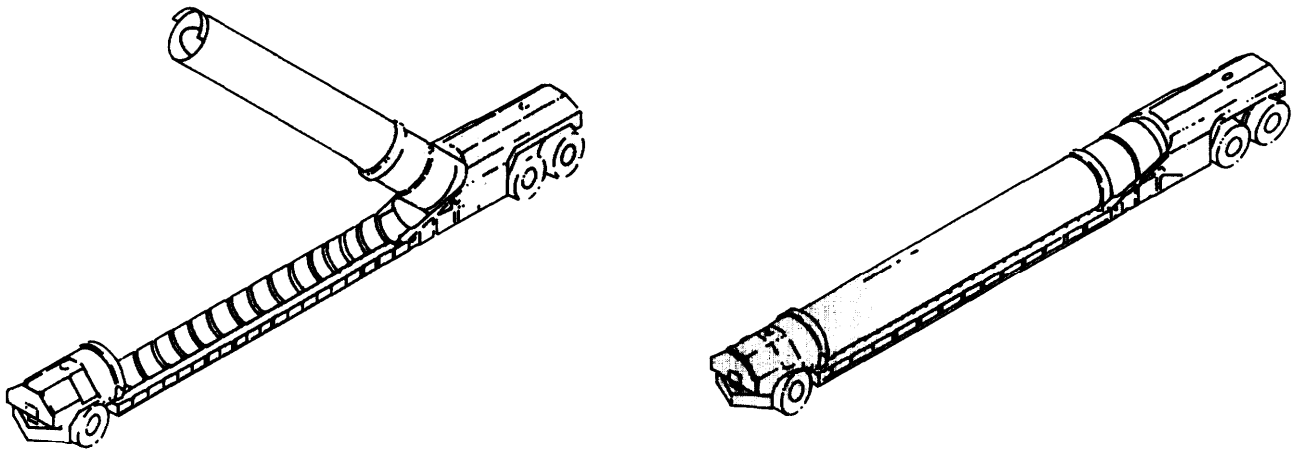
SOURCE: Office of Technology Assessment

Figure 120.—Mesa/Tunnel Concept Plan View Schematic



SOURCE: Office of Technology Assessment.

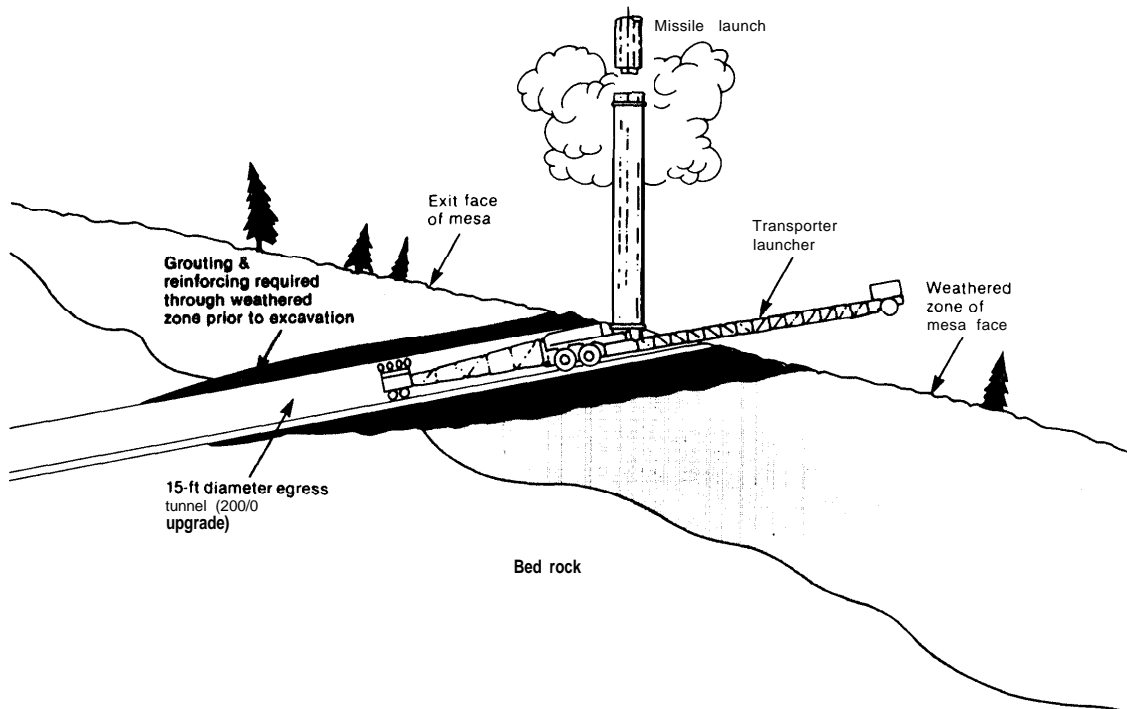
Figure 121.—Transporter Launcher



Length	-	35m	(115 ft)
Width	-		(11.5 ft)
Height			(17.5 ft)
Weight		135,000kg	(300,000lb)
Drive motors (3)		350hp each	

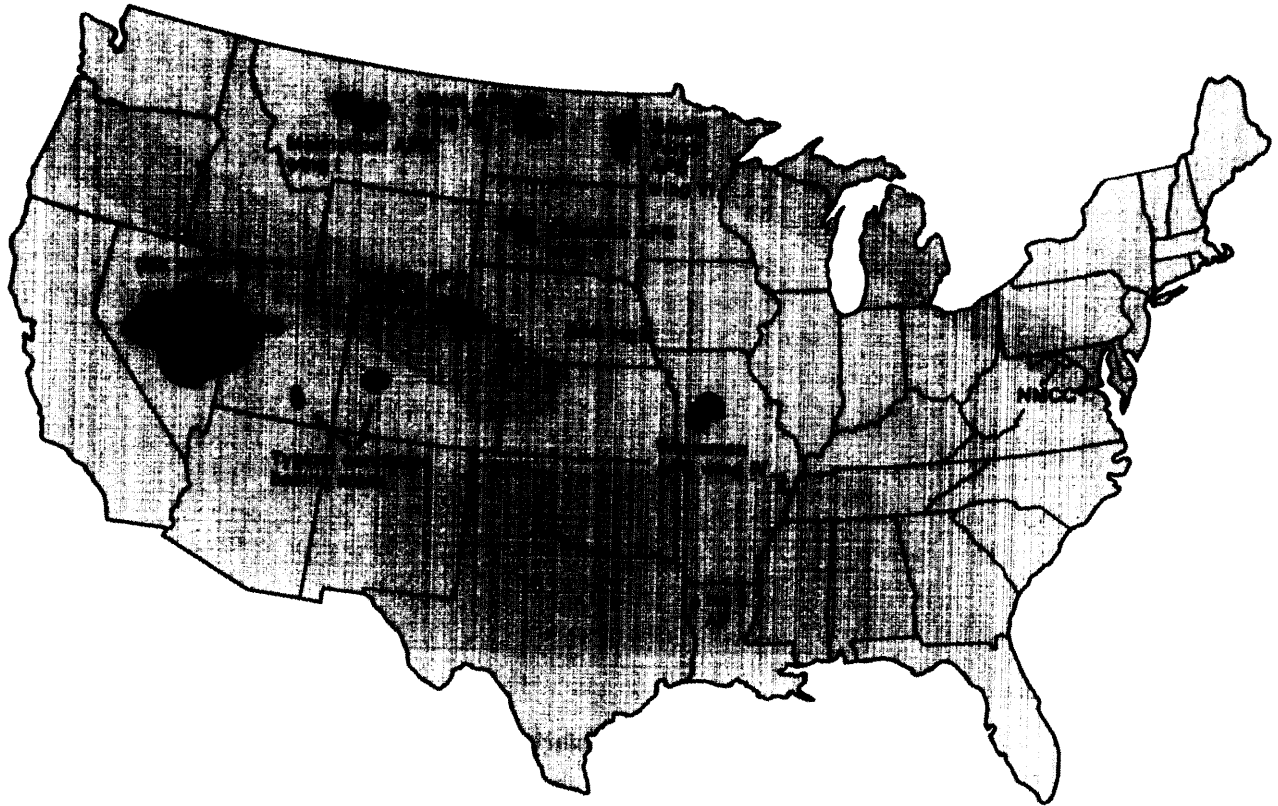
SOURCE Off Ice of Technology Assessment

Figure 122.— Missile Launch



SOURCE Off Ice of Technology Assessment

Figure 123.—Land Area Requirements



of Technology Assessment.

Chapter 10

**COMMAND, CONTROL, AND  
COMMUNICATIONS (C<sup>3</sup>)**

# Chapter 10.–COMMAND, CONTROL, AND COMMUNICATIONS

	<i>Page</i>
Overview. . . . .	277
Technical Aspects of Strategic C <sup>3</sup> . . . . .	278
Communications Links. . . . .	278
Vulnerabilities of Communications Systems, . . . . .	281
Command and Control. . . . .	283
C Functions for MX Basing. . . . .	284
Preattack Functions.. . . .	284
Transattack and Postattack Functions. . . . .	285
C <sup>3</sup> Systems for MX Basing Modes . . . . .	285
Baseline MPS System . . . . .	286
MPS 13 Using With LoADS ABM System. . . . .	289
Launch Under Attack. . . . .	290
Small Submarines . . . . .	290
Air Mobile MX . . . . .	293
Overview of Radio Communications. . . . .	294
Radio Wave Propagation . . . . .	294
Disruption of Radio Communications Due to Nuclear Detonations . . . . .	296

## TABLE

	<i>Table No.</i>
34. Radio Communications Bands. . . . .	279

## FIGURES

	<i>Figure No</i>
124 Communications System for Baseline MPS System (Transattack) . . . . .	286
125 Possible Additions to Baseline MPS Communications System (Transattack). . . . .	288
126 Communications System for Baseline MPSSystem (Postattack) . . . . .	288
127 Possible Additions to Baseline MPS Communications System (Post attack). . . . .	289
128 Preattack C <sup>3</sup> System for Small Submarines . . . . .	291
129 Transattack C <sup>3</sup> System for Small Submarines . . . . .	292
130, Postattack C <sup>3</sup> System for Small Submarines. . . . .	293
131 Transattack Air Mobile MX Communications System . . . . .	294
132. Physical Paths of Radio Waves . . . . .	295
133. Electromagnetic Transmission Ranges at Different Frequencies . . . . .	295
134, Over-the-Horizon Radio Transmission . . . . .	296
135. Geometry of Aircraft Direct Path Communications.. . . .	296
136 Geometry of Satellite Communications . . . . .	297
137 Electromagnetic Pulse Ground Coverage for High-Altitude Nuclear Explosion . . . . .	297
138 Origin of Electromagnetic Pulse From High-Altitude-Nuclear Explosion. . . . .	298
139 Atmospheric Radio Propagation at Different Frequencies. . . . .	299
140 Radio Propagation Paths Before and After High-Altitude-Nuclear Explosion . . . . .	299

# Chapter 10

## COMMAND, CONTROL, AND COMMUNICATIONS (C<sup>3</sup>)

---

### OVERVIEW

A missile force that physically survives an attack is of no use if the means to command the force do not survive as well. Reliable command, control, and communications (C<sup>3</sup>, pronounced "C-cubed"), impervious to Soviet attempts at disruption, are needed if commanders are to assess the status of an MX force, retarget the missiles if desired, and transmit launch commands. There is a wide variety of technical possibilities for wartime communications and just as wide a range of means to disrupt and impede them. The nature of the disruption suffered by the U.S. C<sup>3</sup> system in wartime would depend on the amount of damage done to communications installations themselves and on the extent of disturbance of the atmosphere due to nuclear explosions. Though some disruption would inevitably result regardless of the nature of the Soviet attack, the most stressing circumstance would result from a deliberate Soviet attempt to deny U.S. commanders the means to control and execute their forces.

It will be apparent that no single communications link can be made absolutely survivable, but disruption can be made difficult, time-consuming, provocative, and costly of Soviet resources. Multiple links can also be provided, subject to different failure modes, and provision can be made for reconstituting some links if the primary system is destroyed.

The actual functions that a C<sup>3</sup> system supporting an MX force must fulfill depend to some extent on doctrine for the force's use. At a minimum, the communications system must be consistent with the operations of the force (e.g., must not compromise missile location in multiple protective shelter (MPS) basing or submarine location in submarine basing) and must permit one-way communication of short launch commands (Emergency Action Messages— EAMs) from commanders to the mis-

siles to order execution of preplanned options of the Single Integrated Operational Plan (SIOP). In addition, it could be desirable for the C<sup>3</sup> system to support prompt response to launch commands ("responsiveness"), flexible or ad-hoc retargeting outside of the SIOP, and two-way communications so that the forces could report their status to commanders and confirm execution of orders. Last, if the force expected attrition in an attack, it could be desirable for the surviving missiles to be able to redistribute targets among themselves so that the highest priority targets were always covered by surviving missiles. For a given basing mode, the hardware to carry out these functions, and the functions themselves, can differ substantially from the preattack or peacetime period to the transattack and postattack periods.

OTA has sought to prescribe a technically feasible C<sup>3</sup> system that satisfies these criteria for each of the principal basing modes. In many cases the system described differs substantially from those that are available to U.S. forces today. Obviously, providing these systems would involve some cost, but with the exception of launch under attack, in no case is C<sup>3</sup> a cost driver for the basing mode as a whole. Some elements of these C<sup>3</sup> systems would furthermore support other strategic and conventional forces, so their costs should perhaps not be assigned entirely to the MX basing mission.

There are distinct and important differences from basing mode to basing mode regarding both the technical means to support effective C<sup>3</sup> and potential vulnerabilities. In each case it appears that with adequate funding and effort, acceptable technical solutions are available, though it would be extremely difficult to provide a C<sup>3</sup> system survivable against any and all contingencies. Direct comparisons are difficult, but on balance OTA can see no clear rea-

son for preference among the basing modes on the basis of C<sup>3</sup>.

The next section discusses the technical aspects of strategic C' in general terms, including available means of communication and their vulnerabilities. The following section lays out

in concrete terms the functions desired from a C<sup>3</sup> system supporting MX basing. The next section describes the C<sup>3</sup> systems for the basing modes and describes how they might function before and after attack. The last section contains a technical overview of radio communications.

## TECHNICAL ASPECTS OF STRATEGIC C<sup>3</sup>

### Communications Links

The communication of information between two points requires an intervening communications link. For instance, a telephone microphone converts acoustic signals (i.e., a human voice) into electrical signals, and the earphone converts the electrical signal back into sound. The lines over which the signal travels between the phones is referred to as the communications link. By bouncing radio waves off the ionosphere, it is possible to communicate over very great distances. In the case of this type of communications, the path over which the radio wave travels is the communications link. At very high radio frequencies, radio waves are not reflected by the ionosphere. In order to achieve long-range communications in this case, it is necessary to transmit the signal to a satellite that then retransmits it back to Earth. The channel established through the satellite is called the communications link. This seemingly expensive and complex method of radio communications is valuable for two reasons:

1. Satellite communications links can achieve high data rates relative to radio communications that require reflection from the upper atmosphere.
2. Satellite links, if they are not destroyed, are extremely reliable, since communications capabilities do not change with the fluctuating conditions in the upper atmosphere.

The time it takes to transmit a message of a given length over a communications link is determined by the data rate of the link. Any message, whether transmitted by voice, teletype, or picture, can be expressed as a se-

quence of "on or off" signals called bits. The data rate is the number of bits per second that can be transmitted over a particular link. Teletype rates are typically a few hundred bits per second. Since each sequence of five to seven bits would be enough to represent a letter of the alphabet, and since on the average there are five letters per word of the English language, a 300 bit-per-second teletype link could carry 8 to 12 words per second. Voice communications require data rates of several thousand bits per second. High-frequency satellite links can transmit data at hundreds of millions of bits per second. These data rates could support tens of thousands of separate voice channels. A particularly important type of message in the case of strategic C' is the EAM. These messages, ordering a strike by U.S. strategic forces, could be preformatted and might consist of a small number of bits, since even a format with a small number of bits would lead to a large number of possible messages that could have the same format. For instance, if EAMs consisted of 20 bits, then more than a million different messages with the same format could be created. EAMs can therefore be very short messages and can be transmitted in a short time even by links with relatively low data rates. Much more information would have to be transmitted to order a strike that was not among the preplanned options. A high data-rate link would be required to transmit such long messages in a short time.

### Land lines

Landlines consist either of wires that conduct electricity or of glass fibers (i.e., fiber-optic) through which light can be guided.



Both types of landlines can be used for extremely high data-rate communications and are therefore very useful for communicating with land-based strategic weapons systems. The communications links and nodes associated with landlines, however, are vulnerable to physical destruction in war and are subject to disruption or destruction by electromagnetic pulse (EMP) generated by high-altitude nuclear bursts. Landlines might therefore only be of use before an attack on a land-based strategic weapons system.

## Radio Links

Radio communication bands are, by convention, referred to by acronyms. Since these acronyms are commonly used in discussions of communications systems, they are summarized in table 34.

### VLF/LF

**Very low frequency (VLF) and low frequency (LF)** radio signals are useful for reliable communication over very large distances. A powerful VLF/LF station can be received over distances of many thousands of miles, even if there are nuclear detonations in the upper atmosphere. VLF/LF signals penetrate seawater well enough to make communications possible with submarines and, at a cost in data rate, can be made resistant to jamming. VLF/LF radio has two important drawbacks: the antennas required for transmission and reception must be very large and are therefore susceptible to physical destruction, and the data rates that

are possible with VLF/LF are low. However, airplanes are able to trail large antennas in flight and transmit sufficiently powerful VLF/LF radio waves to permit long-range communications. Airplanes can communicate with ground stations, other aircraft, and submerged submarines in this way.

### MF

**Medium frequency (MF) radio links are higher frequency than VLF/LF radio links and can be used to transmit information at higher rates than is possible with VLF/LF.** (The reason for this and other features of radio propagation is discussed in the Overview of Radio Communications section.) MF radio is in the same band of frequencies as AM radio broadcasting. Like AM radio, MF signals do not, under normal conditions, propagate much further than the length of a metropolitan area, though at night skywave propagation can lead to longer range. MF is a reliable means for moderate data-rate transmissions over short distances. Since the radio signals at these frequencies do not travel very far, they are generally (but not always) difficult to jam from great distances. Distances over which communications at these frequencies can generally be affected are 40 to 50 miles between ground stations and **100** to 150 miles between an airplane and a ground station.

### HF

**High frequency (HF) (“short wave”) radio signals are extremely useful for long-range**

Table 34.—Radio Communications Bands

Name of Range	Frequency	Range*	Wavelength Range
Extremely low frequency	ELF	.3-3 KHz	1,000-100 km
Very low frequency	VLF	3-30 KHz	100-10 km
Low frequency	LF	30-300 KHz	10-1 km
Medium frequency	MF	300-3,000 KHz	1,000-100 m
High frequency	HF	3-30 MHz	100-10 m
Very high frequency	VHF	30-300 MHz	10-1 m
Ultra high frequency	UHF	300-3,000 MHz	100-10 cm
Super high frequency	SHF	3-30 GHz	10- 1 cm
Extremely high frequency	EHF	30-300 GHz	1 -1 cm

\*Hertz = cycle per second, KHz= KiloHertz = 1,000 cycles per second, MHz= MegaHertz = 1,000 KHz, GHz = GigaHertz = 1,000 MHz.

tm = meter= 328 feet, km= kilometer= 1,000 meters= .6212 miles, cm = 01 meters= 394 inches.

moderately high data-rate communications. In contrast to VLF/LF radio systems, HF equipment and antenna systems are compact and do not require large amounts of power. A serious problem with HF band communications is that they are easily disrupted by nuclear detonations in the upper atmosphere, and can be "blacked out" over very large distances for periods of hours. Another problem with HF communications is the possibility of using direction finders to determine the location of the transmitter well enough to attack it. A possible further problem with HF is that the number of usable frequency bands is limited. Many users trying simultaneously to use HF could jam one another.

In spite of these drawbacks, the upper atmosphere would recover electrically several tens of hours after nuclear detonations occurred and would then be able to support the long-range transmission of HF. For this reason, HF would be useful for an indefinite period after a nuclear attack for high-data-rate communications even if other communications links were destroyed.

Today's fielded HF systems require manual tuning, introducing some unreliability even in day-to-day peacetime communications. Microprocessor-tuned HF systems resulting from technology improvements would make HF highly reliable except in periods of significant blackout.

#### VHF

Very high frequency (VHF) waves are not strongly reflected from the upper atmosphere and do not travel far over ground. VHF is the band at which FM radio broadcasts occur, and it is familiar to radio listeners that FM stations have shorter range than AM stations. Very high data rates are possible with VHF, and antennas and equipment can be made compact.

Long-range communications are possible using VHF by reflecting radio signals off the ionized trails of meteors. Since it is necessary to have a reflecting meteor trail in the right location of the upper atmosphere to permit communications between two points beyond

the radio horizon, delays of a few minutes could occur before it would be possible to transmit a message using VHF. One possible advantage of VHF is that it might be possible to communicate effectively by bouncing radio signals off the bottom of the ionized region formed by a high-altitude burst. Thus, VHF communications might actually be improved if the Soviets blacked out HF or UHF.

#### UHF

Ultrahigh frequency (UHF) is extremely useful for line-of-sight communications between aircraft. The data rates are high and the equipment is quite compact and low power. UHF can be used to communicate to ground installations from an aircraft at a distance of about 200 miles and can be used to communicate between aircraft at distances between 300 and 450 miles. For this reason, UHF could be used to communicate between airborne command posts and to transmit launch commands to land-based missiles.

It is possible to use direction-finding techniques to locate UHF transmitters and it is also possible to jam receivers. This problem is unlikely to be serious for line-of-sight aircraft communications but it could be a problem for UHF links through satellites.

### Satellite Communications (SATCOM)

#### UHF SATCOM

UHF satellite links are useful not only because data rates can be very high, but also because UHF antennas are not extremely directional, so users do not have to have means for pointing antennas at satellites. A drawback of UHF SATCOM links is that it is possible to jam the uplinks to the satellites from small mobile jammers (ship or ground mobile) located anywhere in the satellite's hemisphere of view. A problem associated with the multidirectional nature of UHF signals is that enough signal can be "seen" from other directions that it is in principle possible to locate ground-based UHF transmitters from space. Nuclear detonations in the upper atmosphere can also result in "blacking out" of UHF

signals for a few hours over regions of the Earth's surface. These regions of blackout would have radii of tens to hundreds of miles. The United States now uses UHF SATCOM regularly for worldwide military communications.

UHF satellites could be launched from silos into low orbit in wartime to reconstitute disrupted links.

#### SHF/EHF SATCOM

Super high frequency (SHF) and extremely high frequency (EHF) satellite links are extremely useful for very high data rate, reliable communications. Because of the large bandwidth, such links are, at least for EHF, unjammable. Because the wavelengths are so short (on the order of fractions of a centimeter), it is possible to have very highly collimated radio beams that can be trained on the satellite. In addition, SHF/EHF antennas are sufficiently small (about 5 inches in diameter) that they can be conveniently mounted on ground vehicles, aircraft, surface ships, and submarine masts.

Since the SHF/EHF beam is so tightly collimated, it is nearly impossible for a receiver that is not in the beam to "see" the signal. The only way that the presence and location of an SHF/EHF transmitter could be detected would be if the search receiver was itself in the beam. Thus, SHF/EHF satellite uplinks from forces in the field, surface ships, and submarines would not pose the risk of revealing the location of the transmitters.

A potential problem with SHF/EHF is an atmospheric phenomenon called scintillation. Electron density fluctuations in the ionosphere due to high-altitude nuclear bursts could cause the beam to be bent as it propagated through them. This bending would result in fluctuations in the quality of reception at the receiver. It is believed that with suitable signal modulation scintillation would not be a problem at all. For EHF, scintillation would not last, in any event, for more than a few minutes after a high-altitude burst. Another minor problem is that water absorbs EHF signals. However, a major rainstorm would be required to impede

communications. Mist and clouds would not be a problem.

#### LASER SATCOM

The high frequencies and directional nature of laser communication allow for extremely high-data-rate, low power consumption, unjammable links between satellites and between satellites and aircraft flying above the clouds. Communications between ground stations and satellites would not be feasible because of the possibility of cloud cover. Even in clear weather, such communications would create a visible pencil of light in the sky, revealing the location of the user. For this reason laser SATCOM might endanger the covertness of submarines, surface ships, and mobile ground units.

## Vulnerabilities of Communications Systems

### Physical Destruction

One obvious way to attempt to deny communications capability to U.S. strategic forces would be to physically destroy as many susceptible elements of the system as possible. This destruction would include landlines, landline switching stations, radio transmitter stations (i.e., VLF/LF/MF, etc.), satellite up-and-down-link stations, and fixed command centers.

After an initial attack, it could not be guaranteed that landline communications would exist with land-based forces or that fixed VLF stations would be broadcasting to the submarine forces. Only communications links made possible with aircraft and satellites would necessarily still be intact.

### Electromagnetic Pulse (EMP)

An effect of the detonation of nuclear weapons, both inside and outside the atmosphere, that is less appreciated but still very important is EMP. The case of a detonation outside of the atmosphere is, however, the most relevant as a general problem for communications systems.

As explained in the *Overview of Radio Communications* section, a high-altitude nuclear detonation could generate a sudden electric field over large regions of the United States of up to 50,000 volts/meter. This intense electric field could destroy or disrupt communications and electrical equipment of all types. High quality assurance and testing are required to ensure that components are properly sealed and protected if they are to survive the effects of the EMP from high-altitude detonations.

### Ionospheric Disruption

Another effect of high-altitude nuclear detonations is ionospheric disruption. The electron densities in the ionosphere would be changed suddenly by the ionizing effects of prompt gamma rays from the nuclear detonation and/or beta rays from fission decay products. These effects could cause significant degradations at those radio frequencies that are reflected from (HF) or pass through (UHF SATCOM) the ionosphere.

### Jamming

Jamming refers to the ability of a hostile transmitter to drown out the signal being received. The susceptibility of a radio link to jamming depends on power, bandwidth, modulation technique, and antenna directivity. In general, jamming becomes more difficult as the frequency of the transmission increases. If the nature of potential wartime jamming can be foreseen, it can be compensated by changes in modulation technique and increases in power.

### Anti satellite (ASAT) Threats

There is considerable concern that the heavy dependence of the U.S. military on SATCOM will make satellites the targets of attack. The means of attack could be direct-ascent interception, space mines, land-based lasers, or even space-based lasers.

Several of the basing modes discussed in this report could make effective use of SATCOM. A highly reliable SATCOM system based on deep-space millimeter-wave (E H F) communica-

tions has been proposed for military use and would be very useful to support MX basing. The following discussion explains why there is considerable interest in such satellites.

Though geosynchronous orbit would be most convenient for such satellites operating at EHF frequencies, it would perhaps be advisable to deploy them in higher orbits. Geosynchronous orbit is that unique orbit 22,300 miles from the Earth at which the orbital period of satellites is equal to the rotation period of the Earth. Thus, satellites in geosynchronous orbits remain over the same point on the Earth's surface as both they and the Earth go around. Because its position relative to the Earth's surface would remain the same, users would have a fixed point upon which to focus their directional antennas. Because of its convenience, however, geosynchronous orbit is quite crowded. It would therefore be possible for the Soviets to station a "space mine" near a U.S. communications satellite and answer in response to U.S. protests that the mine was in fact some other sort of satellite that it was convenient to position in geosynchronous orbit. The United States would then not be in a position to assert that the Soviets had no business there, because it would be quite plausible that they did have legitimate purposes for positioning a satellite in this unique, convenient orbit.

If on the other hand the U.S. satellites were in an orbit chosen more or less randomly from among the infinite number of possible altitudes, the United States would be in a better position to assert that the only possible purpose for a nearby Soviet satellite must be to interfere with that of the United States. The United States might then justify on these grounds measures against such interference.

Satellites could also be threatened by direct attack from a missile launched from the Soviet Union. However, the U.S. satellites could be positioned high enough that it would take many hours (18 or so) for an attacking vehicle to reach them. Furthermore, since the interceptor missiles required to reach high orbits would be quite large, the Soviets would probably only launch them from the Soviet Union. Most of

the U.S. satellites would be on the other side of the Earth when the first interceptor was launched, and launch of other interceptors would have to be staggered to intercept the rest of the satellites as they "came around." Direct-ascent antisatellite attacks on high orbits would therefore present a timing problem to the Soviets. The United States would certainly be aware that the satellites were under attack hours before they were destroyed.

Last, land-based lasers could not deliver sufficient power to the orbits of interest (five times geosynchronous or so, or half way to the Moon) to destroy the satellites.

A number of measures could be taken to ensure the survival of these satellites. For instance, they could be provided with sensors to allow them to determine when they were under attack, and they could maneuver to avoid homing interceptors and deploy decoys or chaff to confuse homing sensors. Backup satellites at such distances from the Earth might also be able to be hidden entirely by giving them small optical, infrared, and radar signatures. Dormant backup satellites might be hidden among a swarm of decoys and turned on when the primary satellites encountered interference. Last, backup satellites (probably using UHF instead of higher frequencies) could be deployed on missiles in silos and launched into low orbits to replace the primaries. These reconstituted satellites could also be attacked, but it would take time for the Soviets to acquire data on their orbits, even assuming the United States allowed them unhindered operation of the means to acquire this data. Some of these techniques for satellite security are more effective than others.

## Command and Control

This chapter deals for the most part with the communications aspect of C<sup>3</sup>. The command and control functions for U.S. strategic forces are outside the scope of this discussion, but it is necessary to specify how the command structure is linked to the communications system and thus to the forces.

Decisions regarding the use of U.S. strategic forces are in the hands of the National Command Authorities (NCA), i.e., the President and Secretary of Defense or their successors. The military provides a National Military Command System to support NCA. This system consists of fixed command centers and survivable mobile command posts. The fixed ground centers include the National Military Command Center in the Pentagon, an Alternate National Military Command Center at a rural site outside Washington, D. C., the underground command center at Strategic Air Command (SAC) headquarters at Offutt Air Force Base in Omaha, Nebr., and North American Aerospace Defense Command headquarters in Cheyenne Mountain, Colo.

Since the fixed ground centers could be destroyed early in a nuclear war, a fleet of survivable Airborne National Command Posts is provided for postattack command and control. The most important aircraft in this fleet is the E-4B (modified Boeing 747) National Emergency Airborne Command Post (NEACP, pronounced "kneecap") available for Presidential use. In addition, there is a fleet of strip-alert aircraft at military bases throughout the country, including command posts of the nuclear commanders and the Post-Attack Command and Control System (PACCS) fleet. This fleet could establish a network of line-of-sight UHF communications from the Eastern to Central United States within a short time after an attack. Finally, SAC maintains an EC-135 (modified Boeing 707) command aircraft, called "Looking Glass," on continuous airborne patrol over the United States.

Ground-mobile command posts—disguised as vans traveling the Nation's highways to avoid being targeted—are also a possibility for survivable command posts.

In the descriptions that follow of possible C<sup>3</sup> systems for each of the basing modes, it will be assumed that all force management functions and launch commands originate with, *or pass* through, the airborne or grounded NEACP, and that NEACP is provided with the necessary communications systems to link them with the MX force.

## C' FUNCTIONS FOR MX BASING

This section outlines the functions desired of an MX C<sup>3</sup> system to support the various aspects of U.S. Nuclear Weapons Employment Policy. These policy aspects are associated with such terms as Basic Employment Policy, Flexible Response, Quick Reaction Hard-Target Counterforce, Secure Reserve Force, and the like, as derived from the public statements of senior defense officials. This section translates these notions into concrete functions required of a C<sup>3</sup> system for MX. The next section will prescribe hardware capable of performing these functions for each basing mode.

These functions, and most certainly the means to accomplish them, differ among the preattack, transattack, and postattack periods. For the purposes of this chapter, the transattack period is defined as the period of airborne operation of certain C<sup>3</sup> aircraft (N EACP, Airborne Launch Control Center (ALCC), TACAMO, etc.). The distinction between transattack and postattack as used here therefore concerns the hardware available to accomplish the C<sup>3</sup> functions and not the functions themselves. Transattack and postattack functions will therefore be treated together.

### Preattack Functions

#### Peacetime Operations

Peacetime communications are required for commanders to assess continuously the status and readiness of the MX force. Continuous one-way communications from commanders to the forces is an obvious requirement. Two-way communications—including from the missile forces to commanders—is clearly important, though intermittent report-back (relevant for the case of submarine basing) might be adequate.

Since the communications links have suffered no damage, the only impediment to maintaining adequate peacetime communications would be the requirement that the means of communications should be consistent with the operations of the force. Thus, the peacetime communications should not be of such a

nature as to compromise missile locations in the case of MPS basing or defense unit locations in the case of the MPS/LoADS (low altitude defense system) combination, nor betray the locations of patrolling subs in small submarine basing.

#### Responsiveness

In the event that NCA ordered the launch of the MX missiles according to one of the preplanned options of the SIOP before the force had suffered attack, all that would be required of the C<sup>3</sup> system would be the capability to transmit a short, preformatted, encrypted message to the MX force. Since the message would be short, low-data-rate communications would suffice.

There could be a requirement that missile launch be accomplished rapidly after the decision to launch was made. This could be the case if a Soviet attack were believed imminent and it was thought desirable to strike Soviet forces before they could attack the United States or disperse from their home bases. This requirement of responsiveness would seek to make the time interval between dissemination of the EAM ordering launch and actual missile launch as short as possible. A portion, though not necessarily most, of this time interval would be comprised of the time it took for the relevant communications links to transmit the short EAM to the MX force with low probability of error.

In order to strike certain hardened targets such as missile silos, it would also be desirable to be able to control the arrival times of RVS so that detonation of one would not compromise the effectiveness of others ("fratricide"). Such time-on-target control could be accomplished by including in the EAM a reference time, relative to which each missile would determine the *arrival time* required of its RVS in order to coordinate arrival with RVS from other missiles. The precise timing would be achieved by coordinating launch time, maneuvers of the missile, and reentry angle.

In addition to short response time, it could be desirable for the MX force to be able to communicate back to the commanders in a short time to confirm successful launch.

### Ad-Hoc Retargeting Before Launch

Ad-hoc retargeting refers to the ability to construct attacks that are not among the preplanned options of the SIOP. Such retargeting flexibility could involve either rearranging targets from the extensive target sets already stored in the MX missile launcher's memory or reprogramming the missile with entirely new target sets. Both situations would require transmission of larger amounts of data than contained in the short EAM. In the latter case, the information would include target latitudes and longitudes (calculated in the proper coordinate system), reentry angle, timing, and fuzing.

Since large attack options would likely be included among the S IOP options, extensive ad-hoc retargeting might be confined to a relatively small portion of the force, in which case only that portion need be in a position to receive such high-data-rate communications.

The portion of the force retargeted would presumably be required to report back receipt of the new targets, confirm them, and report successful launch.

## Transattack and Postattack Functions

### Prelaunch Damage Assessment and Reoptimization Within the SIOP

In the event that the MX force suffered attrition in the attack, it might be desirable for the surviving missiles to reallocate targets in such a way that the highest priority targets continued to be covered even if the missiles that originally covered these targets were destroyed in the initial attack.

Commanders would presumably also wish to know the extent of attrition and remaining target coverage.

### Order for Launch of Preplanned Options

Dissemination of the EAM after an attack would require that the surviving portion of the C<sup>3</sup> system support at least one-way low-data-rate messages. Report-back confirming successful launch would require two-way communications. It is not clear that the need for *rapid* response would always be as great in the postattack period as in the preattack period.

### Ad-Hoc Retargeting

Assignment of entirely new targets to the MX missiles and confirmation of receipt would require teletype data-rate two-way communications.

## C<sup>3</sup> SYSTEMS FOR MX BASING MODES

In this section, the problems of providing effective C<sup>3</sup> for each of the principal basing modes are discussed and technically feasible solutions identified. In many instances, the C<sup>3</sup> system described for hypothetical future MX basing modes differs substantially from C<sup>3</sup> systems supporting present strategic forces. These systems would have to be acquired at some cost, though in no case (excluding launch under attack) is the C<sup>3</sup> system a major cost driver for the system as a whole. Moreover, some of the communications systems described would be useful for other military missions in addition to MX basing. OTA has only identified

feasible C<sup>3</sup> systems and has not attempted to find a "best" solution. Also, the systems have not been subjected to the cost tradeoffs that could occur if a decision were made to deploy one of them.

The baseline MPS system is in full-scale engineering development and subject to certain budgetary constraints. It is therefore natural that the baseline system could be improved on (e.g., with regard to two-way long-haul communications) with additional funding. Since for the other basing modes similar funding constraints have not been applied to the C<sup>3</sup>

systems described here, feasible improvements to the baseline MPS system—available at some additional cost — are identified.

### Baseline MPS System

#### Preattack

Peacetime MPS C<sup>3</sup> operations would be accomplished principally through the fiber-optic network linking each shelter with the Operational Control Center (OCC) and with other shelters. Each fiber cable would contain three lines (one for communications in each direction and one spare) capable of 48 kilobit/second data rates. With such high data rates, launch orders and retargeting information could be transmitted in a very short time. Response time to an EAM would be driven by operational procedures and by the several minutes it would take the missile to emerge from the shelter and erect.

PLU would be maintained by having the missiles and simulators transmit encrypted status messages with identical formats according to uniform message protocols.

#### Transattack

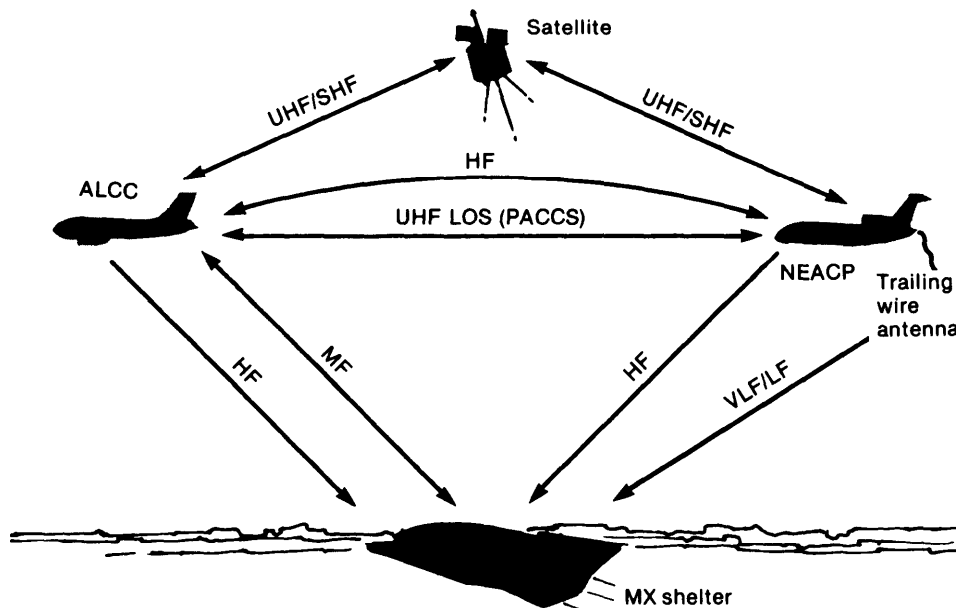
The transattack period is defined in this chapter to comprise the period of airborne operation of the ALCC and NEACP. One ALCC would always be airborne in peacetime, with another *on strip alert*. The in-flight endurance of the **ALCC** would be about 14 hours, after which communications would have to be accomplished from the grounded aircraft to the MPS shelters.

The transattack C<sup>3</sup> system for the baseline MPS system is shown in figure 124.

Communications between the ALCC and NEACP are relatively secure. Immediately after the attack, however, the HF and UHF SATCOM could be disrupted, and it would take some time to set up the UHF line-of-sight PACCS net.

Of the links from the ALCC to the shelter, HF (line-of-sight) could be disrupted by the nuclear environment, and MF represents a compromise between the better propagation of low frequencies through an ionized at-

Figure 124.—Communications System for Baseline MPS System (transattack)



SOURCE: Office of Technology Assessment.



mosphere and the higher data rates of high frequencies.

MF, which has short range, would be the only means in the present baseline system design by which the shelters could communicate with the ALCC to report their status. Transmission would be through the buried MF dipole antenna at each shelter. Taking into account soil propagation losses, the effective radiated power from each shelter would be only about 2 watts. The low power of the transmitter at each shelter would be multiplied by the “simulcast” technique where each surviving shelter *that contained an MX missile* would transmit its status via MF. Other surviving shelters receiving this message would repeat the transmission simultaneously with rebroadcasts by the original shelter. In this way, after many repetitions, all of the surviving shelters would be transmitting, in sequence, the status message of each individual shelter, with a total effective transmitting power of all the shelters taken together.

Since only the shelters containing MX missiles would be transmitting in this period, these emissions might reveal the locations of the surviving missiles if the Soviets could detect them. However, the short range of ground-wave MF would preclude direction-finding by remote ground stations or ships, and ionospheric absorption and refraction would prevent satellites from detecting and locating the emissions. Thus, this hypothetical threat to PLU may be impossible for the Soviets to capitalize on. This security from detection is one of the reasons why MF communication was chosen.

The simulcast would also be used to enable the surviving missiles to redistribute targets among themselves in order to maintain coverage of the highest priority targets. The missiles would be numbered 1 through 200, and for each SIOP option there would be 200 target sets, numbered 1 through 200 in priority order. Before the attack, missile #1 would have target set #1, missile #2 target set #2, and so on. After the attack, missile #200 would listen on the MF simulcast for a status message from missile #1.

If missile #1 did not report or reported that it was unable to fire, missile #200 (if it survived) would assume target set M. If missile #2 had not survived, its target set would be assumed by missile #199 (if it survived), and so on.

Transattack *two-way* communications between the ALCC and the missile force would rely exclusively upon the single MF link. Since MF is short-range, the ALCC would have to approach within 50 to 100 miles of the missile field in order to receive the MF simulcast and assess the status of the force. There could be concern for the effects upon the ALCC of dust and radiation lofted into the atmosphere by the attack.

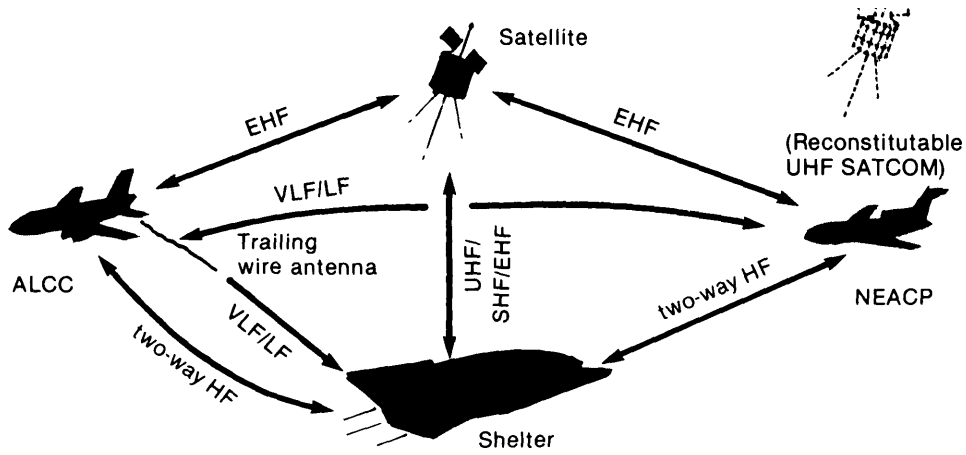
This situation could be improved by providing HF transmitters (as well as receivers) and/or SATCOM terminals at the shelters, as shown in figure 125. A UHF SATCOM terminal **would** cost about \$100,000, so SATCOM at each shelter would cost about \$500 million.

## Postattack

The postattack period, as defined for the purpose of this discussion, would begin when the airborne command posts (ALCC and NEACP) were forced to land, either to refuel or for extended grounded operations. The baseline C<sup>3</sup> system for this period is shown in figure 126. HF and MF skywave communications could be disrupted for hours or days after attack. The ground-wave communications would in any case be short range. The ALCC would have to be within 50 to 100 miles of the shelters or it would be out of MF range. The Soviets would not necessarily spare airfields this close to the deployment area. There would therefore be a need for long-haul two-way communications from the grounded aircraft to the shelters in the postattack period. This communication would be needed especially if the ALCC were inoperable, and the grounded NEACP had to communicate with the MX force over thousands of miles.

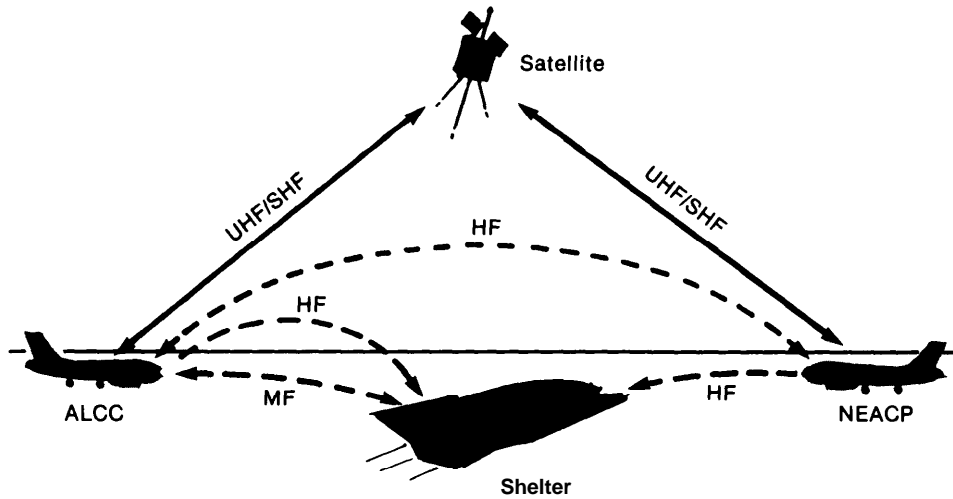
Means to provide these two-way long-haul communications that are *not* part of the present baseline design are shown in figure 127.

Figure 125.—Possible Additions to Baseline MPS Communications System (transattack)



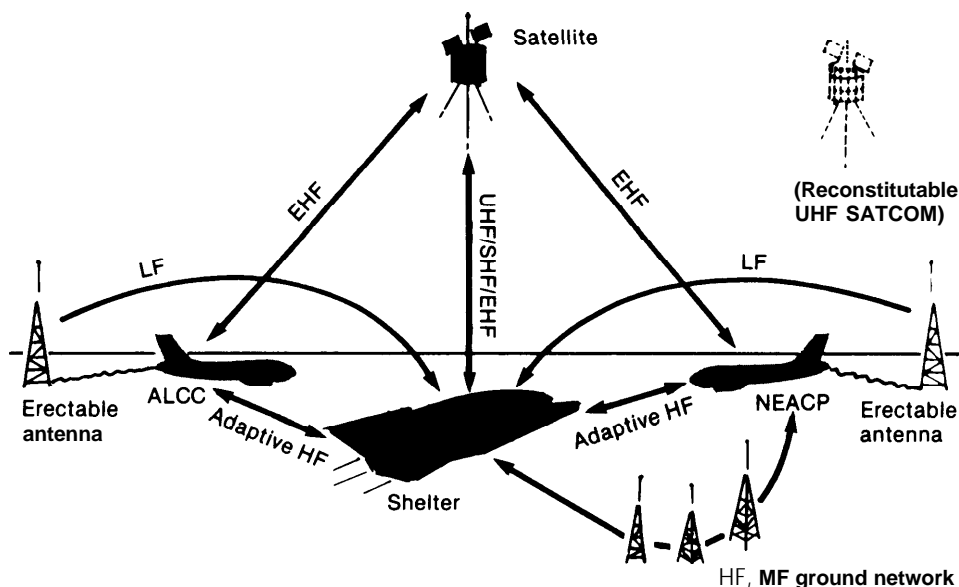
SOURCE: Office of Technology Assessment,

Figure 126.—Communications System for Baseline MPS System (postattack)



SOURCE: Office of Technology Assessment.

Figure 127.—Possible Additions to Baseline MPS Communications System (postattack)



SOURCE: Off Ice of Technology Assessment.

They include adaptive HF, ground-based HF or MF relays proliferated across the United States, satellite communications, and erectable LF antennas.

### MPS Basing with LoADS ABM System

The two principal C<sup>3</sup> functions required if LoADS were added to MPS basing would be: 1) tactical warning of Soviet attack so that the LoADS defense units (DUS) could break out of their shelters and prepare to defend; and 2) communications to transmit a breakout order and authorization to activate the nuclear-armed interceptors ("nuclear release").

If the design goal providing for awakening dormant electrical equipment in the DU and breaking the radar and interceptor canister through the shelter roof within a very short period of time could be achieved, warning of

Soviet attack would not be required until late in the flight of the Soviet ICBM reentry vehicles (RVS). Means to provide such late warning (within 15 minutes of impact) could include rocket-launched sensor probes, sensor aircraft, and ground-based radars, in addition to satellites. Such warning sensors are discussed extensively in chapter 4. Radars similar to the LoADS radars themselves could be positioned at the northern edges of the deployment area. The sensors could provide attack assessment if such information were required to attempt to limit degradation of defense effectiveness in the face of a potential Soviet Shoot-Look-Shoot capability (see ch, 3). Without adequate warning for breakout, the LoADS defense would clearly be useless. If breakout occurred in peacetime as a result of error, the shelters containing the LoADS DUS would be destroyed.

Though it might be feasible physically to activate the defense in a short time, the procedures whereby commanders assessed the warning information and ordered breakout and nuclear release could in practice lengthen the response time considerably. In the present LoADS command concept, breakout and nuclear release are effected by two distinct commands. The communications needed to support timely activation of the defense would depend on who was authorized to order nuclear release. Offensive nuclear release must be ordered by NCA. Whether authority for defensive nuclear release could be delegated to military commanders is unclear.

At the time the breakout and release orders were given, detonations of Soviet SLBM RVS could already have occurred in the deployment area and at other centers of the National Military Command System. MF injection from the ALCC might therefore be the only means to transmit the defense commands. If the ALCC operating area were expanded by using longer range communications (H F or VLF/LF) between the ALCC and the shelters, the lower data rates could lengthen the time it would take to transmit commands to the defense.

At present, uncertainties in the LoADS system architecture and unresolved operational procedures do not permit judgment on the feasibility of supporting the defense's warning and breakout needs.

If a LoADS defense were added to a vertical-shelter MPS system, the radar and interceptor cannister would have to be emplaced in separate shelters. In this case it would probably be necessary to deploy a separate communications network to support the rapid transfer of data from the radar to the interceptors in an engagement.

### Launch Under Attack

Warning and communications systems to support reliance upon launch under attack are discussed extensively in chapter 4. Since these systems would be the only "basing mode" to speak of, considerable time, effort, and money

would presumably be spent assuring their reliability in the face of determined Soviet efforts at disruption. As discussed in chapter 4, it would be technically feasible to deploy a wide variety of warning sensors and communications links to airborne command posts that, taken together, would be exceedingly difficult for the Soviets to disrupt. Such disruption could furthermore be made time-consuming and provocative.

What cannot be determined on the basis of technology alone is whether information provided by remote sensors would be adequate to support a decision of such weight as the launch of U.S. offensive weapons, whether procedures could be devised to guarantee timely decisions by NCA, and whether (given the complex interaction of human beings and machines operating against a short timeline) a bound could be set and enforced upon the probability of error resulting in catastrophe.

### Small Submarines

Since seawater absorbs radio waves of all but the lowest frequencies of the radio spectrum, completely submerged submarines are confined to low data-rate receive-only LF, VLF, and ELF communications. Two-way communications and high data rates require putting either a mast antenna or a trailing buoy antenna above the surface. While the buoy or mast antenna itself poses essentially no threat to submarine covertness, broadcasts at moderate frequencies could reveal the locations of the submarines. E H F communications to survivable deep-space satellites such as have been proposed for a wide variety of military communications missions would permit high data-rate communications from submarines to commanders with essentially no risk to submarine covertness. Present U.S. fleet ballistic missile submarines use a variety of classified means for report-back.

This section describes a technically feasible C<sup>3</sup> system to support small submarine basing of MX. The system described differs somewhat from the C' system that supports present sub-

marine forces and intends to provide the small submarine force with some of the attributes of a land-based missile force.

### Preattack

#### SYSTEM DESCRIPTION

The preattack C<sup>3</sup> system is shown in figure 128.

The land-based VLF transmitters exist at present. The network provides worldwide coverage and would be more than adequate for the small submarine deployment area. The transmitters have high power, adequate anti-jam capability, and can transmit an EAM to submerged submarines in an extremely short time. There is also a worldwide LF network.

The EHF satellites do not exist at present, but a similar satellite (LES 8/9) has been deployed with great success. EHF frequencies are chosen because jamming them is virtually impossible, submarines can communicate with virtually no chance of betraying their locations, data rates are high, and small (5 inch) mast antennas can be used. Such satellites in deep-space orbits could be made exceedingly

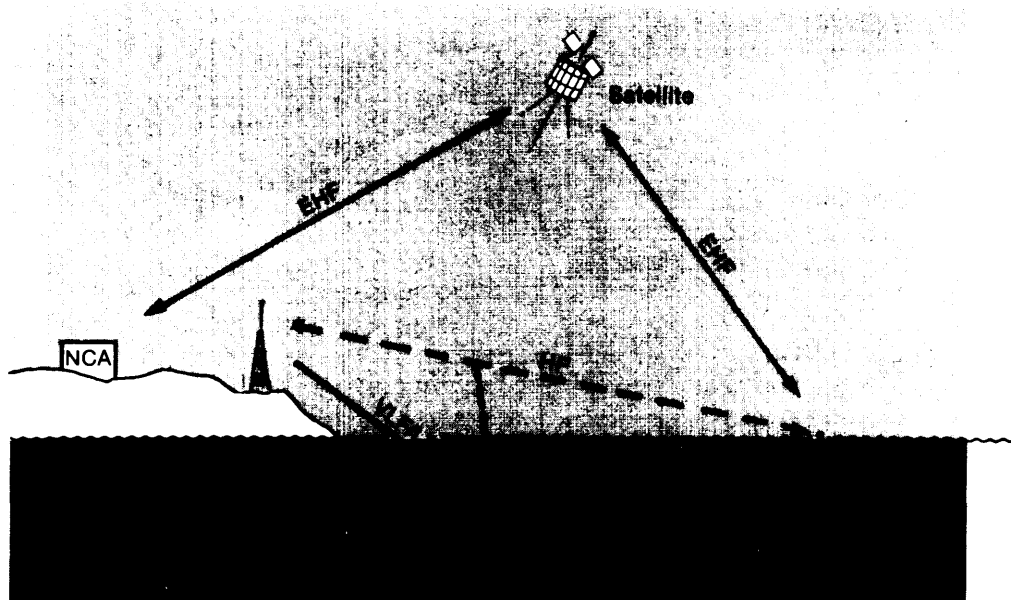
difficult for the Soviets to disrupt (see the discussion of ASAT in the Technical Aspects of *Strategic C3* section).

#### PREATTACK FUNCTIONS

peacetime covert operations could be accomplished in the same way as with the present submarine force copying VLF. The VLF network would also permit transmission of an EAM in an extremely short time. The SIOP would contain a timing plan, keyed to a reference time in the EAM, to allow the missiles to coordinate their time-on-target. Depending on where it was in the deployment area, each missile would calculate a launch time, reentry angles, missile maneuvers, and bus deployment to provide the required time-on-target coordination. Coverage and footprinting could be arranged by advance operational planning.

Ad-hoc targeting instructions for limited nuclear options could be assigned to 10 to 12 percent of the force that would be snorkeling at any given time. These submarines could be copying high data-rate SATCOM via their mast antennas. If a larger portion of the force were required for ad-hoc retargeting, the VLF net-

Figure 128.—Preattack C<sup>3</sup> System for Small Submarines



SOURCE: Office of Technology Assessment

work could direct more submarines to erect their masts or deploy awash buoys to copy other communications.

Report-back could be arranged, at no additional risk to the submarines, by having them transmit status messages via EHF SATCOM whenever they snorkeled. Classified means are used today for submarine report-back.

## Transattack

### SYSTEM DESCRIPTION

The transattack period is defined for the purposes of this chapter as the period when NEACP and TACAMO are airborne. This period would normally be the first 12 to 14 hours after attack plus additional periods if provision were made for extended operations. The transattack C<sup>3</sup> system is shown in figure 129.

The land-based VLF antennas are assumed destroyed in the attack, though this might not be true of the antennas on the soil of other nations. The EHF satellites are assumed intact.

There are at present several TACAMO aircraft in the Atlantic and a few in the Pacific.

More Pacific TACAMOS are expected to support Trident operations. These TACAMO aircraft will be EM P-hardened.

Both TACAMO and the E-4B NEACP would be capable of transmitting an EAM directly to submerged submarines from their VLF trailing antennas.

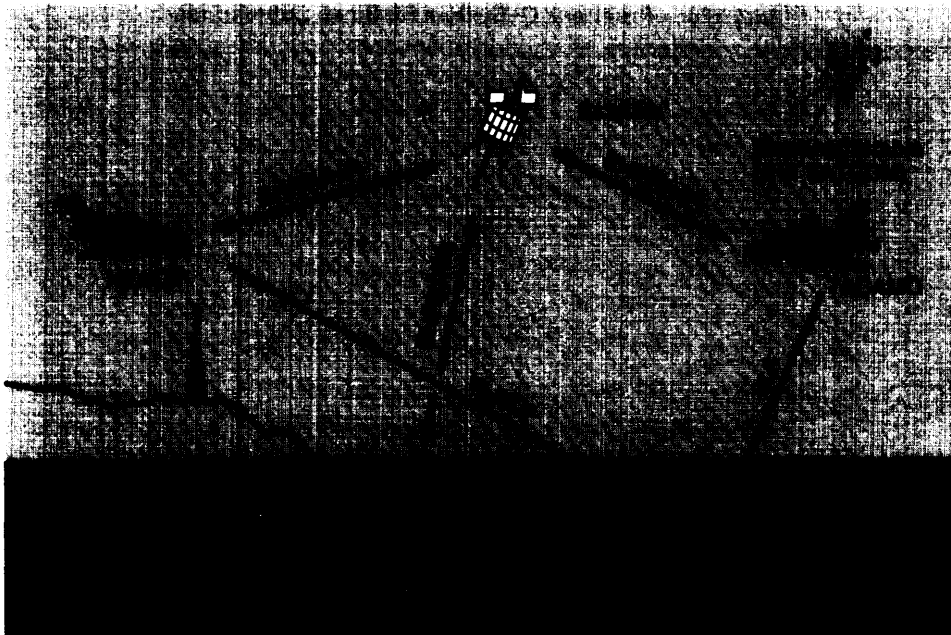
### TRANSATTACK FUNCTIONS

Prelaunch damage assessment and targeting reoptimization would be unnecessary for the small submarine force, since it would be expected to be almost completely survivable.

EAM transmission could occur via VLF from TACAMO or NEACP. When the submarines lost communications with the land-based VLF transmitters, they would tune to TACAMO.

Ad-hoc retargeting would require high data rates and two-way communications, so VLF would not be appropriate. A short-coded message via VLF ordering certain submarines to come to depth and copy targeting instructions via E H F SATCOM would be a means to accomplish ad-hoc retargeting the transattack period.

**Figure 129.-Transattack C<sup>3</sup> System for Small Submarines**



SOURCE Office of Technology Assessment

## Postattack

Two-way communications via EHF SATCOM could be available in the postattack period, and HF and UHF SATCOM could be reconstituted in this period as well. The postattack C<sup>3</sup> system is shown in figure 130.

### Air Mobile MX

#### Preattack

The principal preattack C<sup>3</sup> requirements for an air mobile fleet would concern receipt of timely warning messages to support the fleet's high alert posture. A wide variety of reliable warning sensors, available at some cost, is discussed in chapters 4 and 6. The communications links from these sensors to commanders authorized to order dispersal of the fleet and from commanders to the alert airbases would presumably be used before the communications system had suffered extensive damage.

The responsiveness of an air mobile force to a launch order would be limited to the time—perhaps **10** minutes or so— it would take the

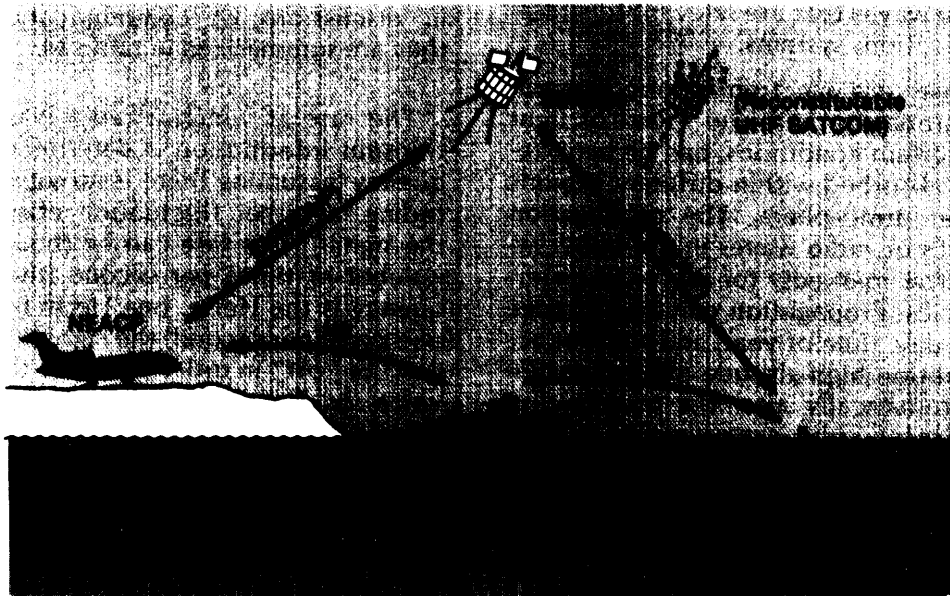
aircraft to take off and climb to launch altitude.

## Transattack and Postattack

The C<sup>3</sup> system to support the complex force management needs of the dispersed MX fleet would require at least teletype data-rate communications between each missile-carrying aircraft and command aircraft. The aircraft would be required to report their status, including remaining fuel supplies, and receive launch instructions. Targeting reoptimization would not be required if a substantial portion of the fleet survived the initial attack. The airborne fleet could make use of a wide variety of communications including UHF line-of-sight (including the PACCS fleet), adaptive HF, VLF/LF, and SATCOM, as shown in figure 131. The communications system itself would be low risk, the principal C<sup>3</sup> problems being associated with the need to manage the dispersed force, assess its status, and ready it for launch.

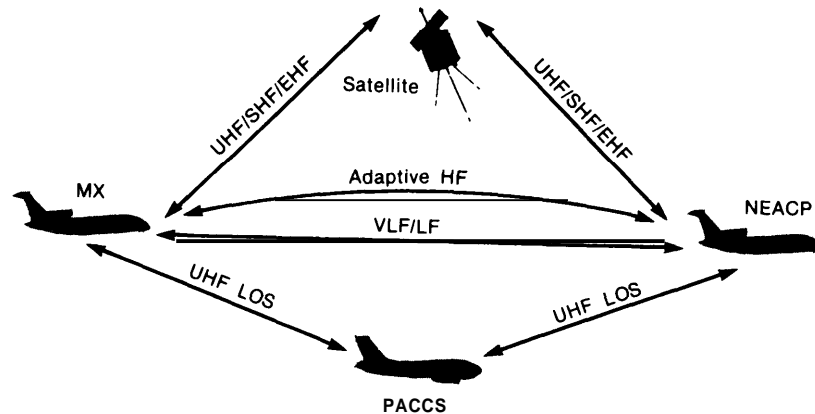
The problems of making provision for endurance beyond the few hours of unrefueled flight time are discussed extensively in chapter 6. If

**Figure 130.—Postattack C<sup>3</sup> System for Small Submarines**



SOURCE: Office of Technology Assessment

Figure 131.—Transattack Air Mobile MX Communications System



SOURCE: Office of Technology Assessment.

airfields survived for reconstitution, they would have to be located, their status assessed (including local fallout levels), and landing aids provided in advance.

Last, providing for missile accuracy comparable to land-based MX would require communications from Global Positioning Satellites (GPS) or a Ground Beacon System (GBS).

## OVERVIEW OF RADIO COMMUNICATIONS

### Radio Wave Propagation

This section discusses some of the characteristics of radio waves that are relevant to strategic communications systems.

Radio waves are electromagnetic disturbances that propagate with the speed of light and, under certain conditions, can be bent, reflected, and absorbed within different regions of the upper atmosphere. The propagation characteristics of radio waves in the upper atmosphere differ markedly for waves of different frequencies. Propagation can also change with time of day, time of year, and sunspot activity. In addition high-altitude nuclear explosions can dramatically alter the propagation characteristics of radio waves within the atmosphere. This circumstance has obvious and important implications for communications systems that may have to function reliably in a nuclear environment.

Radio communications bands are, by convention, referred to by different names. Since the names of these bands are commonly used in discussions of communications systems, they are summarized in table 34.

The rate at which a radio wave is able to transmit information is determined by its frequency (assuming there is no significant noise, fading, or other fluctuation effects mixed in the signal). This rate can be thought of as the number of times per second (the unit of frequency is the Hertz; one Hertz is the same as one cycle per second) the signal can be turned "on" or "off" in order to create the sound of a voice or to transmit information in other forms. This "on-off" rate can never be greater than the frequency of the wave since the frequency of the wave is in fact the number of times per second that the wave itself is turned "on and off." A rough rule of thumb is that a

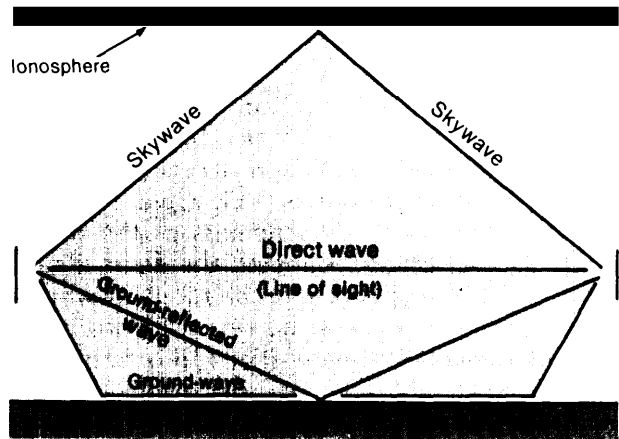


radio signal can carry information at about 10 percent the rate of its frequency. Thus, if low-fidelity voice communication requires the transmission of a voice signal that has primary frequency components in the 1,000 to 2,000 cycle per second range, then the radio wave must have a frequency of at least 10,000 to **20,000** Hertz. This means that the lowest usable frequencies for voice communications lies in the upper end of the LF band. High-quality voice transmission would require the transmission of voice components at frequencies of order 10,000 to 15,000 Hertz, thus requiring frequencies on the order of several hundreds of kiloHertz. These frequencies lie in the lower end of the MF band or broadcast band, where commercial AM radio stations are licensed to operate. For situations that require particularly reliable signal reception and good rejection of noise, much higher frequencies are preferable, as is the case with high fidelity music transmissions that are transmitted in the VHF (FM radio) band. Still higher data rates may be required for transmitting enough information to construct pictures rapidly in time, as is the case in television broadcasting. Television information rate requirements dictate radio frequencies in the VHF and UHF radio bands.

Radio waves can be received between ground stations over several different physical paths. If the stations are close enough together to have line-of-sight contact, they can receive "direct-wave" transmissions (see fig. 132). It is also possible to use different layers of the upper atmosphere to bend or reflect radio waves back toward the surface of the Earth for over-the-horizon reception (or for over-the-horizon radars). Signals received over such paths are called skywaves. Radio waves can also be reflected from the surface of the Earth, to the ionosphere, and back again toward the Earth. This phenomenon, which occurs mostly at lower radio frequencies, can result in the radio wave being "guided" along the Earth's surface for great distances. The radio waves are, in effect, trapped by the boundaries of the ionosphere and the Earth's surface.

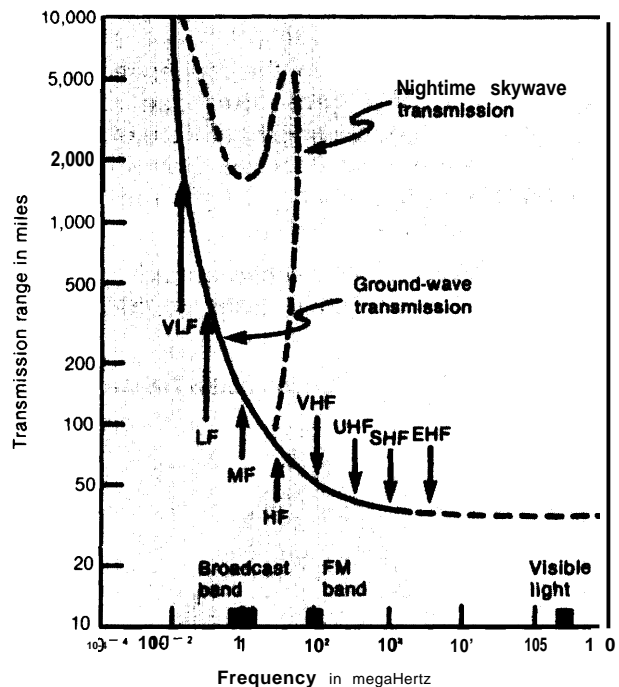
Figure 133 shows a graph of typical distances over which communications can be

Figure 132.—Physical Paths of Radio Waves



SOURCE: Office of Technology Assessment

Figure 133.—Electromagnetic Transmission Ranges at Different Frequencies



SOURCE: Office of Technology Assessment

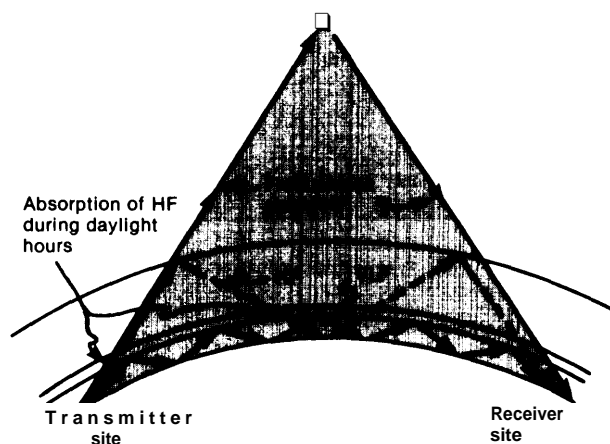
achieved between ground stations using commonly available radio equipment. VLF signals (designated by an arrow at 10 KHz on the graph) can be reliably received at distances of many thousands of miles because they are

guided along the Earth's surface by the boundaries on the ionosphere and the ground (fig. 134 shows the geometry of VLF over-the-horizon radio propagation). At higher frequencies encountered in the LF band, radio waves begin to suffer attenuation at the greater distances due to absorption. As a result of these effects, LF reception tends to be of shorter range than that of VLF waves. At still higher frequencies, less and less of the radio waves get redirected back to the Earth's surface by the ionosphere and the range at which radio transmissions can be received drops to the line-of-sight distance. (For radio transmissions, line-of-sight distances are approximately 40 miles. This distance is somewhat larger than visual line-of-sight distances. ]

Many communications applications require high data rates in addition to long range and high reliability. High data-rate communication mandates the use of high radio frequencies. Since high frequencies are either not reflected or poorly reflected from the ionosphere, it is necessary that the transmitter and receiver have line of sight geometry if reliable communications are to be affected. One way of increasing the range of line-of-sight radio communications is to use airplanes.

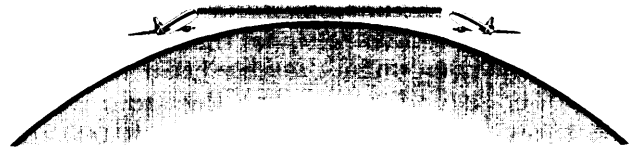
Figure 135 illustrates schematically the geometry for line-of-sight communications be-

**Figure 134.—Over-the-Horizon Radio Transmission**



SOURCE: Office of Technology Assessment

**Figure 135.—Geometry of Aircraft Direct Path Communications**



SOURCE: Office of Technology Assessment.

tween aircraft. As an airborne relay, line-of-sight transmission between aircraft can be affected over distances of approximately 400 miles using the HF and UHF bands. The aircraft can also communicate with ground installations over distances of approximately 200 miles at those same frequencies.

Another feature of aircraft communications links is that they are constantly in motion and are therefore difficult to target from great distances. For this reason, aircraft are particularly useful as survivable command posts, launch control centers, and communications relays.

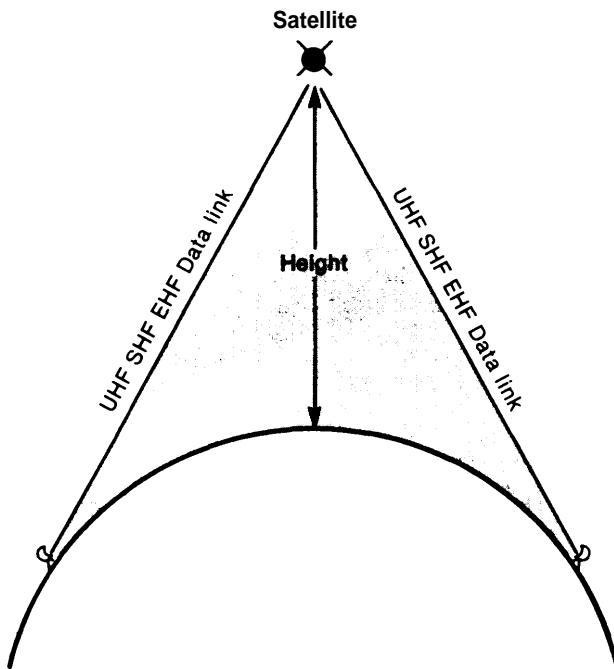
For still greater distances and high data-rate communications, satellites can be used as orbiting relays. The geometry of an orbiting satellite relay is shown in figure 136. A particularly convenient orbit used for long-range, high data-rate satellite communications is at a distance of 22,300 miles from the Earth. Satellites in orbits that lie in the plane of the Equator at that distance will always remain over the same point on the Earth's surface. For this reason, many communications satellites are put in such "geosynchronous" orbits.

## Disruption of Radio Communications Due to Nuclear Detonations

### Electromagnetic Pulse

When a nuclear detonation occurs, a large number of gamma rays is emitted by nuclei in fission and fusion reactions, resulting in an initial "gamma flash" of extremely high intensity. If the nuclear weapon is detonated at an altitude above the sensible atmosphere, the gamma rays from the weapon can induce extremely intense electromagnetic fields in the layer of air between 15 and 25 miles altitude.

Figure 136.—Geometry of Satellite Communications



SOURCE: Off Ice of Technology Assessment

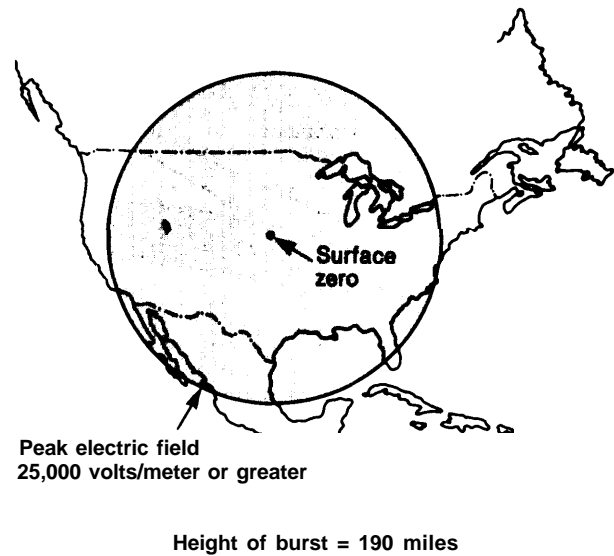
These electromagnetic fields will then propagate towards the surface of the Earth.

Nuclear-explosion-generated electromagnetic phenomena of this type are known as EMP effects. EMP fields are of great interest since they are sufficiently intense to represent a potential threat to the survivability of almost all electronic equipment.

Figure 137 shows the area over which an intense electric field of 25,000 volts per meter or more would be generated by a nuclear explosion of several hundreds of kilotons yield at an altitude of 190 miles. The area affected essentially covers the entire United States and parts of Canada and Mexico.

The size of the area that could be affected by EMP is primarily determined by the height of burst and is only very weakly dependent on the yield. For example, the size of the affected area shown in figure 137 could be increased by 60 percent if the detonation height were increased to an altitude of 300 miles. Thus, severe EMP effects are possible over very large areas without the use of high-yield weapons.

Figure 137.—Electromagnetic Pulse Ground Coverage for High-Altitude-Nuclear Explosion

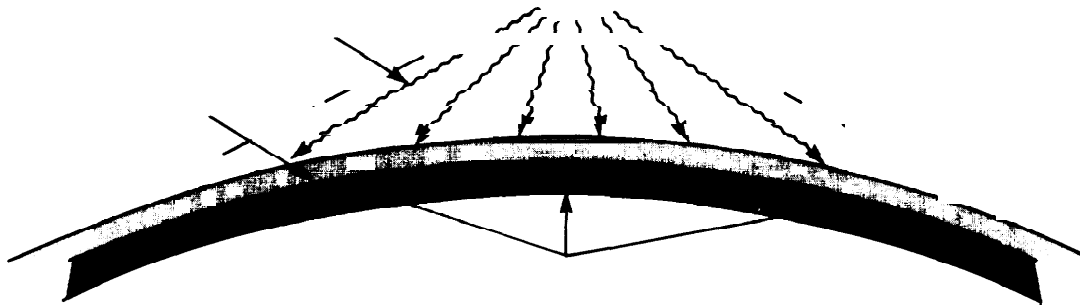


SOURCE: Off Ice of Technology Assessment

The physical reason for the altitude dependence of EMP phenomena can be seen from figure 138. The tangent to the Earth from the burst point determines the maximum range at which the gamma rays can induce intense electromagnetic fields. The gamma rays initially generated by the exploding weapon deposit their energy in a band of the atmosphere between 15 and 25 miles altitude. The electromagnetic field that reaches the surface of the Earth is generated within this band of atmosphere. If the weapon is detonated at a greater height, the tangent will occur at a greater ground range from the surface zero point, and the extent of the gamma ray-induced band will also be greater.

During the initial period of a nuclear attack, intense electric fields from high-altitude-nuclear detonations could cause severe damage to electronic equipment. Powerlines, radio antennas, metal conduits, and other conducting surfaces would collect EMP energy like antennas and destroy or disrupt the electrical equipment to which they were connected. Even equipment that had been carefully designed to survive the effects of EMP could be temporarily disrupted for a period after a high-

Figure 138.—Origin of Electromagnetic Pulse From High-Altitude-Nuclear Explosion



SOURCE: Office of Technology Assessment

altitude nuclear detonation (for instance EMP-protected computers could be disrupted by loss of sections of memory or computation).

### Ionospheric Disruption

Since the gamma rays from a high-altitude nuclear detonation can change the electron densities in very large regions of the ionosphere, the propagation characteristics of radio waves may change dramatically. A result of this change could be a "blackout" of radio communications.

Figure 139 shows the **skywave** paths of radio waves of different frequencies. The D layer of the ionosphere is responsible for **reflecting** VLF and LF radio signals. Nuclear explosions in or above the D layer would change ionization levels in the D layer. The effect of this change would be to lower the altitude at which VLF and LF signals would be reflected from the ionosphere. This effect could disrupt communications over long ranges, but it would be unlikely that VLF and LF communications would be blacked out by nuclear detonations.

MF radio propagation is normally limited to groundwaves because the MF radio waves get absorbed in the D layer before they can reach the upper layers and be reflected back to the Earth's surface. At night, when the lack of sunlight results in a drop in the ionization of the D layer, MF radio may propagate to fairly great distances (see the curve marked night-

time **skywave** transmission in fig. 133). For this reason it is sometimes possible at night to pick up AM broadcasts from remote transmitters. Nuclear explosions in or above the D layer could blackout MF **skywave** communications for hours near the point of detonation.

The HF band is used extensively for **long-range** communications. If conditions in the ionosphere are such that HF waves are not absorbed, HF waves will be bent back to Earth when they reach the E and F layers of the ionosphere (see fig. 139). HF is particularly useful for long-range communications because its frequency is high enough that large amounts of information can be transmitted and yet it is low enough that the ionosphere will bend it back to the surface of the Earth.

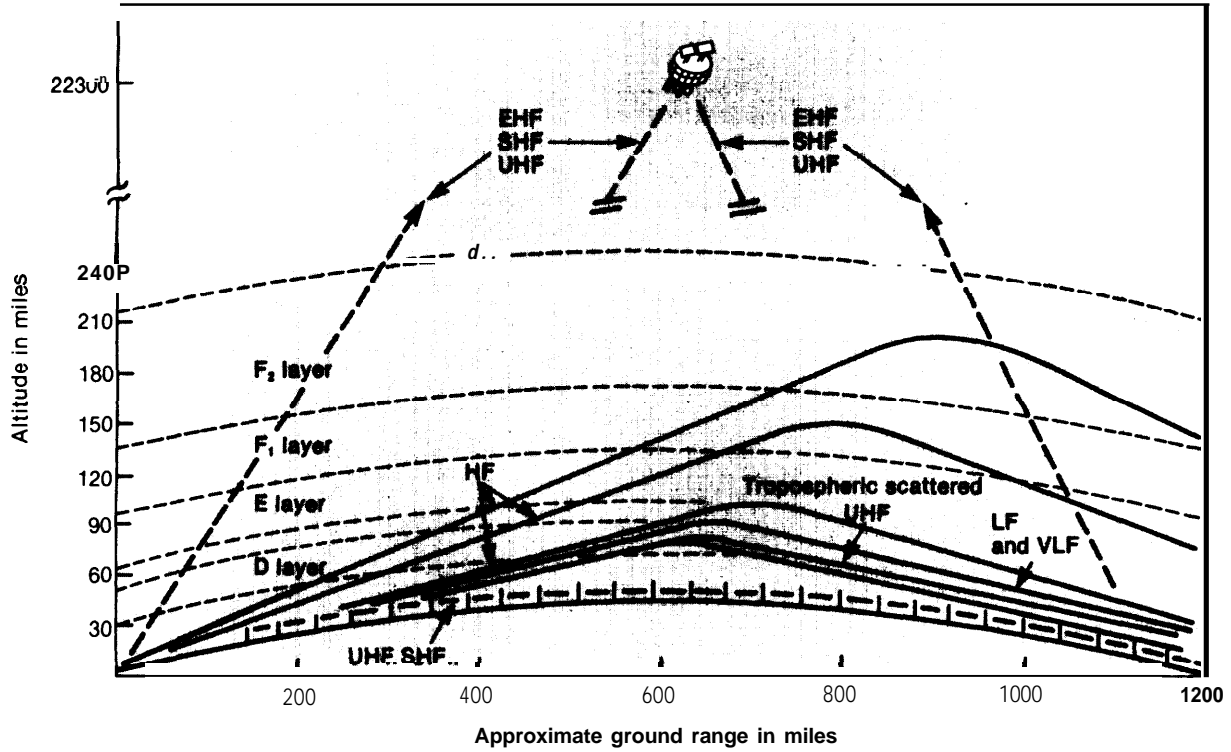
Nuclear detonations in or above the D layer could change ionization levels sufficiently to cause absorption of HF waves in the D layer. The changed ionization levels could also lower the altitude at which HF waves were reflected from the ionosphere (see fig. 140). This change could result in severely degraded HF communications for periods of minutes to hours.

A nuclear burst at an altitude of approximately **200 miles** would be expected to disrupt HF communications over the same area in which severe **EMP** would be experienced. The blackout from such a detonation could last for hours.

In bands above H F, most radio transmissions would suffer varying degrees of degradation through the ionosphere. However, provided

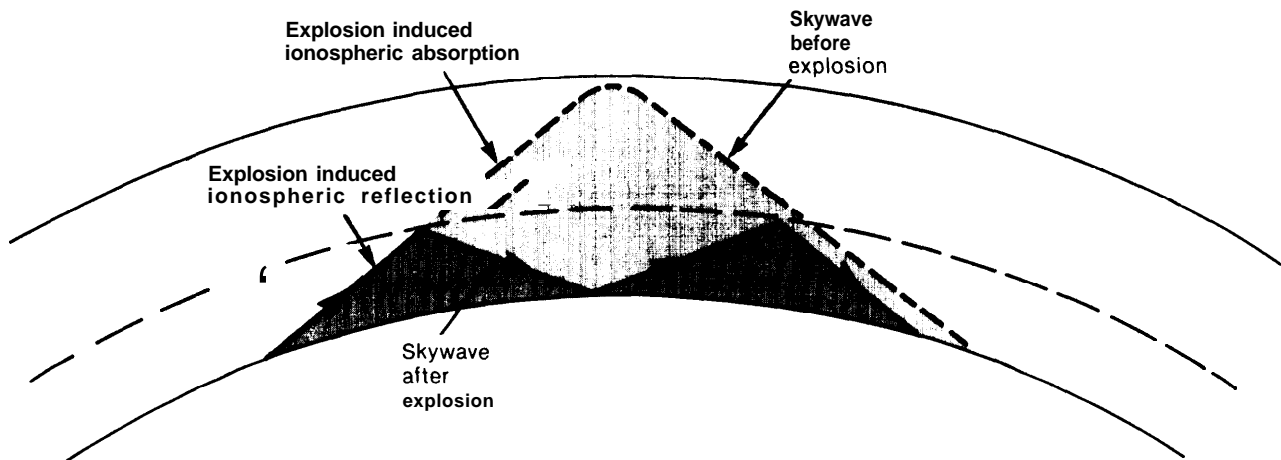
satellites were not attacked, communications at these frequencies would probably not suffer severe degradation.

Figure 139.—Atmospheric Radio Propagation at Different Frequencies



SOURCE Off Ice of Technology Assessment

Figure 140.—Radio Propagation Paths Before and After High-Altitude-Nuclear Explosion



SOURCE Off Ice of Technology Assessment

Chapter 11

**DIVERSITY OF U.S. STRATEGIC  
FORCES**

## Chapter II.— DIVERSITY OF U.S. STRATEGIC FORCES

	<i>Page</i>
Overview . . . . .	303
Diversity and Vulnerability . . . . .	304
Diversity and Weapon System Capabilities . . . . .	305
Diversity and Deterrence. . . . .	307

# DIVERSITY OF U.S. STRATEGIC FORCES

---

## OVERVIEW

Among the many considerations that arise in the selection of a basing mode for the MX missile is the perceived need to maintain diverse U.S. strategic offensive forces. For the past 20 years, the United States has deployed a "Triad" of strategic offensive forces—intercontinental ballistic missiles (I CBMS), submarine launched ballistic missiles (S LBMS), and manned bombers—with each "leg" of roughly equal importance. While the development of these strategic offensive forces did not occur as a result of a conscious policy for the procurement and use of strategic nuclear weapons, the diverse operational characteristics of U.S. strategic forces described briefly below have stimulated the formulation of American nuclear strategies and tactics that seek to optimize the differing capabilities and vulnerabilities of each leg of the Triad.

The following discussion assumes that no matter what basing mode is selected for the MX missile, the United States will also deploy future strategic offensive forces composed of Minuteman ICBMS, manned bombers, and SLBMS on both Poseidon and Trident fleet ballistic missile submarines (SSBNS). For purposes of OTA'S analysis, the MX missile is regarded as an additional strategic nuclear weapons delivery vehicle, rather than a substitute for any existing U.S. strategic offensive nuclear weapon. This assumption is consistent with existing or proposed Defense Department plans.

MX deployed on land in such modes as multiple protective shelters (MPS), defended MPS, defended silos, and in silos relying on launch under attack would continue to provide the United States with hedges against changes in the technological environment of strategic forces. Any of these modes would limit the effects of failures of American

technology encountered in the modernization of the bomber and SLBM legs of the existing Triad. These land-based MX basing modes would continue to provide a hedge against Soviet defenses, and would retain the present characteristics of U.S. strategic offensive forces that make it impossible for the Soviets to plan and execute a preemptive attack against them with high confidence. The land-based MX basing modes would also retain those attributes of strategic offensive forces commonly thought to be the strong points of existing ICBM forces.

Small submarine basing for the MX missile would guard against some changes in the technological environment but not against others. If the Soviet Union were to suddenly develop and deploy an unexpected antisubmarine warfare capability, it might be effective against Poseidon and Trident submarines as well as small submarines carrying MX missiles; there is also a risk that problems with other U.S. submarine construction programs might apply to, or be exacerbated by, small submarine construction. Small submarines could acquire military capabilities quite comparable to land-based MX deployment options. While land-based systems would be somewhat more accurate, OTA'S analyses do not clearly indicate that the differences in accuracy would have militarily significant practical implications.

There is a controversy over whether increasing the importance of sea-based as opposed to land-based strategic forces would strengthen or weaken deterrence.

Air mobile MX would share a common failure mode with the bomber force, but it would not be targetable by Soviet ICBMS.



## DIVERSITY AND VULNERABILITY

Maintaining three completely different types of strategic weapons delivery systems over the past 20 years has provided the United States with an insurance policy of sorts against sudden and unforeseen technological developments. Diversity complicates Soviet efforts to plan and execute a preemptive attack on U.S. strategic forces with high confidence of success.

Diverse U.S. strategic forces complicate Soviet use of air defense, antiballistic missile defense or antisubmarine warfare to prevent destruction of their homeland in the event of an attack by the United States. Diversity in U.S. strategic forces necessitates the division of Soviet offensive and defensive capabilities among several distinct missions, thereby diluting the resources that can be applied to any one mission. The possibility of a sudden and unanticipated technological Soviet development rendering any leg of the U.S. Triad of strategic offensive forces is therefore reduced. Even if the Soviets developed an ability to defend themselves against one leg of the U.S. Triad, other legs could still carry out their strategic missions.

Hence, one criterion that might be used in comparing and contrasting various MX basing modes is the degree to which each basing mode would provide a hedge against vulnerability as a result of the technological change.

MX deployed in an MPS basing mode with or without a low altitude defense system satisfies this criterion, assuming that preservation of location uncertainty (PLU) is maintained and the MX/MPS is deployed on such a large scale that the Soviets lack the number of reentry vehicles (RVS) necessary to confidently attack each MPS. Under these conditions, MX/MPS would provide a hedge against technical problems that might be experienced during the modernization of the manned aircraft and submarine legs of the Triad. The proliferation of targets in the United States would make it sig-

nificantly more difficult for the Soviets to plan and execute a preemptive attack against U.S. strategic offensive forces. Timing and coordinating an attack against 4,600 MX shelters, approximately 1,000 ICBM silos, bomber bases, and the submarine force with high confidence of success would be a virtually impossible task.

MX/MPS might share a vulnerability to Soviet ABM systems with other U.S. ICBMS or SLBMS. However, the deployment of a large MX/MPS system would stress Soviet defense resources in at least two different ways. First, the Soviets would have to invest heavily in the fractionation of their own RVS in order to acquire the number needed to destroy each shelter with high confidence. Second, the Soviets would have to invest in remote sensing, clandestine sensors, and espionage if they were to attempt to compromise PLU. The magnitude of these investments might make it difficult for the Soviets to pursue other strategic programs with the same vigor and commitment of resources possible in the absence of MX/MPS.

Deployment of MX missiles on small submarines provides a hedge against some kinds of technological change. If a sudden and unanticipated technological development in the field of antisubmarine warfare were to occur, and if this development were to simultaneously threaten the Poseidon/Trident force as well as the small submarine/MX force, considerable diversity in U.S. strategic forces would be lost. However, the small submarine basing mode examined by OTA would add considerable diversity to the U.S. strategic missile submarine force. Since the nature of a sudden and unforeseen hypothetical breakthrough in Soviet antisubmarine warfare capabilities cannot be predicted, it is impossible to judge the extent to which diverse submarine types would complicate or frustrate Soviet antisubmarine warfare.

Moreover, deployment of MX missiles on small submarines might not provide an adequate hedge against problems encountered in

**William J Perry, *The F/sea/ Year 1981 Department of Defense Program for Research, Development, and Acquisition* (Washington, D C Department of Defense, 1980), p VI-1**

future U.S. submarine construction programs. Present submarine construction facilities in the United States are backlogged and plagued by management problems. ' If these problems cannot be solved, small submarine deployment of MX missiles might not be an acceptable hedge against technical problems or delays in the deployment of Trident submarines in the late 1980's. The importation of modern, proven diesel-electric submarine technology from our North Atlantic Treaty Organization (NATO) allies might provide a hedge against continued problems in U.S. submarine construction programs.

Air mobile MX could be subjected to attack on the ground just as the manned bomber

---

"Statement of Adm Earl Fowler," U S Congress, House Committee on Armed Services, Mar 12, 1981

force might be. In the absence of adequate warning, both the bomber and air mobile MX force could be destroyed. Air mobile MX would hedge to some degree against improvements in Soviet air defenses that might jeopardize the effectiveness of air-launched cruise missiles or a new penetrating bomber. It would stress the ability of the Soviet Union to deploy a large number of SLBMS close to the continental United States, a capability they do not have today. It would not be targetable by ICBMS.

Deployment of MX in silos and reliance on a doctrine of launch under attack (LUA) completely fails to meet this criterion. MX/LUA would share a common mode of failure with the present Minuteman force that is thought to be vulnerable to a Soviet preemptive attack should there be a failure in warning or communications systems.

## DIVERSITY AND WEAPONS SYSTEM CAPABILITIES

Present U.S. strategic doctrine emphasizes the continuing need for strategic offensive forces that contribute to the deterrence of war by virtue of their diverse military capabilities. As Gen. David Jones, Chairman of the Joint Chiefs of Staff noted in his report to the Congress for fiscal year 1982:

The primary purpose of U.S. strategic nuclear forces is deterrence. To insure deterrence, **these forces must be capable of executing national strategy under all conditions — no matter what the challenge, no matter what tactics an opposing force may choose. While a force composed of a single delivery system could be optimum in certain situations, the United States faces an international environment of diverse threats to national security. To deal effectively with this wide range of strategic uncertainties, U.S. strategic nuclear forces are structured around an array of independent capabilities which can confront any level of nuclear threat.**<sup>3</sup>

---

<sup>3</sup>Gen David Jones, *United States Military Posture for Fiscal Year 1982* (Washington, D C Department of Defense, 1981, P 69

There is a wide range of military capabilities believed to be needed for effective deterrence. The ICBM leg of the Triad has been considered superior to other legs of the Triad in several of these military capabilities in the past.<sup>4</sup> These military capabilities include the following:

- accurate delivery of nuclear weapons (accuracy);
- the ability to carefully control the time at which a nuclear weapon arrives on its target (time-on-target control);
- the ability to change targets assigned to specific strategic nuclear weapon delivery vehicles rapidly (rapid retargeting);
- the ability of strategic forces to respond quickly to attack orders (rapid response); and
- the ability to use a small number of strategic nuclear weapon delivery systems in a flexible, limited manner (flexible use).

---

<sup>4</sup>William J Perry, *The f/sea/ Year 1982 Department of Defense Program for Research, Development, and Acquisition* (Washington, D C Department of Defense, 1981, p Vi-I

Accuracy is necessary to attack targets that have been especially designed to withstand the effects of nuclear weapons. Such targets might include missile silos, communications facilities, specialized industrial facilities, and hardened military facilities.

Time-on-target control is required to prevent the earliest arriving nuclear weapons from destroying subsequent weapons in a multiple weapon attack against a specific target. Time-on-target control may also be required in certain attack tactics in which the destructive effects of nuclear weapons are compounded through use of multiple, closely spaced weapons against adjacent targets.

Retargeting of nuclear weapon delivery systems is desired in those cases where the President chooses an attack option from a menu of preplanned attack options or alternatively decides to attack a specific target that might not be included in a particular attack option. The ability to retarget a strategic nuclear weapon delivery vehicle may also be required in the event that some portion of the force is destroyed and a retaliatory attack against important targets is ordered. Retargeting of surviving forces would be necessary to ensure that high-priority targets would be attacked by surviving forces.

Rapid retargeting is desired to give the President more options as new information is provided about the scope, magnitude, and apparent political objectives of an attack, or alternatively, to permit maximum flexibility in the use of a force as it suffers attrition during the course of an attack against it.

Rapid response to launch orders, referred to as Emergency Action Messages, may be desired in order to take advantage of current intelligence about the disposition of high-value targets. Rapid response may also be desired in the event that an attack against U.S. forces is detected, thereby permitting the launch of forces prior to their destruction.

Flexibility for limited attacks may be desired so that political decision makers can attempt to control the pace of escalation, trying to

limit the scope and magnitude of a nuclear war to a level less than all-out or cataclysmic war.

Comparison of various MX basing modes against these desired weapon system capabilities leads to the following observations.

MX deployed in an MPS mode with or without defense, in defended silos, or in silos relying on launch under attack would retain and increase the military capabilities of the presently deployed ICBM leg of the Triad of U.S. strategic offensive forces in terms of accuracy, time-on-target control, rapid retargeting, rapid response, and flexibility for limited attack.

Small submarine-based MX would also expand the military capabilities of U.S. strategic forces and could come quite close to the land-based MX basing options. While small submarine based MX would not have accuracy quite as high as land-based MX, the difference between the two could be so small as to be of little practical consequence unless time-urgent hardened targets of interest in the Soviet Union were significantly more resistant to nuclear weapon effects than currently believed.

Time-on-target control for small submarine based MX missiles could be comparable to land-based missiles if the command and control system deployed to support small submarine-based MX permitted communication of information needed to plan and execute such attacks.

Rapid retargeting of small submarine-based MX missiles could be comparable to land-based missiles. Retargeting of MX missiles deployed on small submarines to take attrition of the small submarine force into account could be more difficult than would retargeting of land-based MX missiles; however, attrition of small submarines appears far less likely than attrition of the land-based MX force.

Small submarine-based MX missiles could have response times comparable to land-based MX if the communications systems supporting them were properly designed and implemented. They would have very great flexibility for use in limited nuclear exchanges. Unlike

larger Poseidon or Trident submarines, use of an MX missile from a small submarine would compromise the location of only a small fraction of the MX force on station at any given time. Were one MX used, only three additional MX missiles would be placed in jeopardy, as compared with 15 Poseidon missiles or 23 Trident missiles in the event that one missile were to be launched from the larger submarines. On the other hand, the launch of one land-based MX missile exposes no additional missiles to possible immediate counterattack.

Air mobile and surface ship mobile MX might not be quite as accurate as either land-based MX or small submarine-based MX mis-

siles. In addition, the need for aircraft carrying MX missiles to take off and reach altitude to drop missiles or surface ship carrying MX missiles to deploy to areas within range of land-based missile navigation aids would substantially reduce their ability to exercise time-on-target control and responsiveness. Furthermore, these operational requirements might provide the Soviets with strategic warning of a pending American attack.

Surface ship mobile would provide considerably less flexibility for limited use, given that the use of one MX missile would compromise the location of large number of unused missiles carried aboard the surface ship.

## DIVERSITY AND DETERRENCE

There is a wide range of views on the differences among various basing **modes for the MX missile** in terms of continued maintenance of strategic nuclear deterrence. The following discussion summarizes the major points of view.

One view holds that the United States must retain a substantial portion of its most militarily capable strategic forces on the continental United States in order to effectively deter the Soviet Union from initiating attacks on either the United States or our allies. Russell E. Dougherty, retired Commander in Chief of the Strategic Air Command, summarized this view:

**attacking the MX or any other land-based ICBM located in the American heartland forces an aggressor into the open. There can be no ambiguity about an attack of the magnitude required to blunt even a small portion of the U.S. ICBM force. Such an attack would involve a very large number of ICBM warheads with a flight time of about 30 minutes from Soviet launch sites to U.S. targets. The attacker knows that the intended victim knows with certainty and in some detail that a strike has been launched.** The attacker also is aware that the victim has enough time to react to this unambiguous act, and probably will.<sup>5</sup>

<sup>5</sup>Russell E. Dougherty, "The MX Missile System — Keystone of a Modern Strategic Nuclear Force," *AEI Foreign Policy and Defense Review*, Vol. 2, No. 6, December 1980, p. 7

Hence, deployment of the MX missile on land drives up the threshold of attacks on the United States, risking perhaps millions of American civilian casualties, and, at least in this view, assuring American retaliation. Deployment of air mobile MX would have similar consequences were the Soviets to attempt to attack this mode.

Another view holds that deployment of the MX on the continental United States is politically important in the context of broader U.S. efforts to win support for NATO theater nuclear forces modernization and promotion of meaningful negotiations for Mutual and Balanced Force Reductions in Europe.

Adherents to these views tend, therefore, to look with disfavor on the deployment of MX missiles on either small submarines or surface ships arguing that retention of the current balance of capability among land-, sea-, and air-based legs of the Triad is essential to the maintenance of deterrence.

Others believe that the United States need not create additional targets on the continental United States with the selection of a basing mode for the MX missile. Retention of Minuteman ICBMS, bomber bases, submarine bases, and the addition of shore support facilities for either small submarine basing of MX missiles

or surface ship mobile MX would still force the Soviets to expend a sufficiently large fraction of its strategic forces to make clear its intent.

Deployment of MX missiles at sea, it is argued, reduces the amount of damage that might be done to the United States as a result

of radioactive fallout from an attack on MX/MPS, MX/defended MPS, air mobile MX, or silo-based MX. As a result deterrence could be strengthened because the United States would be better able to exercise escalation control with less of its population at risk as a result of the MX basing at sea.

Chapter 12

ARMS CONTROL CONSIDERATIONS  
AND MX BASING OPTIONS

## Chapter 12.—ARMS CONTROL CONSIDERATIONS AND MX BASING OPTIONS

	<i>Page</i>
Overview . . . . .	311
Basing Modes Inconsistent With Arms Control Agreements in Force . . . . .	312
ABMTreaty . . . . .	312
OuterSpaceTreaty . . . . .	312
SeabedTreaty . . . . .	312
OtherArms Control Agreements in Force Affecting MX Basing Decisions . . . . .	313
Limited NuclearTest Ban Treaty . . . . .	313
SALT I Agreements. . . . .	1 1 3
ImpactofSALTIIonMX Basing . . . . .	315
Other PendingArmsControl AgreementsAffectingMX Basing . . . . .	318
Future ArmsControl Negotiations . . . . .	,319
ArmsControl and Stability . . . . .	)22

# ARMS CONTROL CONSIDERATIONS AND MX BASING OPTIONS

## OVERVIEW

This chapter discusses several ways in which arms control considerations bear on the choice of a basing mode for the MX missile. These include the impact of arms control agreements in force, the impact of agreements signed but not yet ratified, and the possible impact of various MX basing modes on future arms control negotiations. \*

The 1972 ABM Limitation Treaty would prohibit the deployment of MX missiles in any mode defended by an antiballistic missile (ABM) system unless such deployments occurred within the Grand Forks, N. Dak., Minuteman field. The Treaty would also prohibit the deployment of ABM systems that were not of a type explicitly permitted by Article I II.

The Seabed Arms Control Treaty would prohibit deployment of MX missiles in fixed shelters on the seabed floor or on any seabed-mobile platform. The Outer Space Treaty presently in force and the proposed SALT II Treaty would prohibit deployment of MX missiles in any mode which launched nuclear weapons into Earth orbit. None of these basing modes appears attractive at this time.

Other arms control agreements either in force or still awaiting ratification would permit most MX basing modes. The proposed SALT II Treaty would prohibit deployment of surface ship mobile based MX as well as inland waterway variants of surface ships, submarines, or deployment on the bottom of lakes, rivers, canals, or other inland waterways. The SALT I

Treaty would not prohibit other basing modes assessed in this study if deployments could be made in a manner that would permit verification, through use of national technical means, of U.S. compliance with the terms of the Treaty were it in effect.

Minuteman III rebasing in a multiple protective shelter (MPS) mode could be undertaken if the SALT II Treaty limits were still in effect after 1985; however, the limits on the total number of MIRVed ballistic missiles would, if still in effect, prevent the United States from deploying an economical mix of missiles and shelters for Minuteman III/MPS to keep pace with plausible Soviet threats unless the number of U.S. submarine-launched ballistic missiles (SLBMS) armed with multiple independently targetable reentry vehicles (MIRVs) deployed were decreased.

The 1963 Limited Test Ban Treaty that is presently in force, and the 1974 Threshold Nuclear Test Ban and the 1976 Peaceful Nuclear Explosions Treaties that are signed but still awaiting U.S. ratification, contain provisions that limit the ability of the United States and the Soviet Union to conduct nuclear weapons explosions useful in generating empirical data that would be helpful in designing both basing modes and attack strategies against them.

Most basing modes for the MX missile pose relatively few future arms control negotiating problems. MPS basing for MX and Minuteman III raises serious negotiating problems because a very high premium is placed on limiting the number of RVS the Soviets can deploy on intercontinental ballistic missiles (ICBMS). MPS also would compel arms control negotiators to specify procedures for verification at a level of detail not successfully negotiated in earlier arms control negotiations.

\* This discussion is restricted to an assessment of the arms control implications of basing mode options only. For a detailed analysis of the arms control implications of the MX missile itself, see "ICBM Programs," in U S Congress, House Committee on Foreign Affairs and Senate Committee on Foreign Relations, *Fiscal Year 1982 Arms Control Impact Statements* (Washington, D C U S Government Printing Office, 1981), pp 26-71, passim



## BASING MODES INCONSISTENT WITH ARMS CONTROL AGREEMENTS IN FORCE

Most basing modes considered for the MX missile are not prohibited by arms control agreements currently in force. However, three treaties contain specific provisions that would be contravened by some basing modes for the MX missile.

### ABM Treaty

As noted in chapter 3 the 1972 ABM Limitation Treaty prohibits widespread ABM deployment to defend MX missiles in any basing mode. In addition, it also constrains deployment of a limited ABM system in numbers of radars, ABM launchers, and ABM interceptor missiles and restricts such deployment to the vicinity of the Grand Forks, N. Dak., Air Force Base.

### Outer Space Treaty

Article IV of the 1967 Outer Space Treaty provides:

States Parties to the Treaty undertake not to place **in orbit around the Earth any objects carrying nuclear weapons or any other kinds of weapons of mass destruction, install such weapons on celestial bodies, or station such weapons in outer space** in any manner.

This prohibition would be a legal barrier to any deployment of MX missiles that were used to launch nuclear weapons into Earth orbit under any circumstances. \*

There are major technical obstacles to the deployment of militarily effective nuclear weapons aboard Earth-orbiting platforms. These obstacles include accurate delivery of a nuclear weapon to a fixed point on the Earth and maintenance of adequate command and control over an orbiting platform during a nu-

<sup>\*</sup>"Outer Space Treaty," in U.S. Arms Control and Disarmament Agency, *Arms Control and Disarmament Agreements, 1980 Edition* (Washington, D C U S. Government Printing Office, 1980), p 52 Cited below as *Arms Control/ Agreements*.

<sup>\*</sup>A similar obligation is found in the proposed SALT II Treaty.

clear conflict. Launching nuclear weapons into orbit cannot now be regarded as a technically attractive basing mode for the MX missile.

### Seabed Treaty

A third arms control treaty containing provisions that would rule out a basing mode that is technically feasible is the 1971 Seabed Arms Control Treaty. Article 1 provides:

1. The States Parties to this Treaty undertake not to emplace or emplace on the seabed and the ocean floor and **in the subsoil thereof beyond the outer limit of a seabed zone, as defined in Article 11, any nuclear weapons or any other types of weapons of mass destruction as well as structures, launching installations or any other facilities designed for storing, testing or using such weapons.**<sup>2</sup>

This provision would prohibit the deployment of MX missiles on various platforms that crawled along the seabed floor, in silos dug into the ocean floor, or in other fixed structures attached to the ocean floor.

Mobile platforms that crawled along the seabed floor would be detectable with various underwater remote-sensing equipment. Like other large land-mobile systems, seabed crawling platforms would not be fast enough to escape a determined effort to barrage attack their last known positions. While the ocean would provide some degree of protection from some nuclear weapon effects, seabed crawlers carrying MX missiles would nevertheless be vulnerable to nuclear weapons attack. Fixed shelters or silos dug into the seabed floor would have similar vulnerabilities.

Moreover, there would be many complicated, expensive, and technically challenging operational problems to be met before such a system could be deemed a technically feasible

<sup>2</sup>"Seabed Arms Control Treaty," In *Arms Control/ A-reempt*, p 102

**basing mode for the MX missile.** Hence, it does not appear that the Seabed Arms Control

Treaty prohibits the deployment of the MX missile in any attractive basing mode.

## OTHER ARMS CONTROL AGREEMENTS IN FORCE AFFECTING MX BASING DECISIONS

### Limited Nuclear Test Ban Treaty

The 1962 Limited Nuclear Test Ban Treaty prohibits the detonation of nuclear explosive devices in the atmosphere, under water, and in outer space.<sup>3</sup> These limitations on nuclear weapons testing prevent the United States or the Soviet Union from conducting nuclear explosions that could generate empirical data about nuclear weapons effects that might be needed to resolve major technical uncertainties in areas such as the following: the hardness of vertical and horizontal protective shelters; nuclear weapon effects on aircraft, surface ships, and submarines, or other vehicles used to carry MX missiles; the effects of nearby nuclear detonations on ABM systems and components; nuclear weapons effects on communications during and immediately after an attack; the effects of multiple nuclear weapon detonations in close proximity to a small number of protective shelters; and the development of strategies and tactics to attack or to defeat an attack on **MX/MPS deployments. However, the amount of technical risk for each basing mode introduced by the lack of atmospheric nuclear weapons test data is relatively minor** in comparison with technical risk created by other factors.

### SALT I Agreements

The SALT I Agreements of 1972 contain several provisions that might affect MX basing decisions. The SALT I Agreements consist of two separate agreements: The 1972 ABM Limitation Treaty previously discussed, and the Interim Agreement on Strategic Offensive Forces.<sup>4</sup> The Interim Agreement on Strategic

Offensive Forces, however, was an Executive Agreement and was affirmatively endorsed by the House of Representatives and the Senate pursuant to section 33 of the Arms Control and Disarmament Act of **1961. It set limits on the numbers of ICBM and SLBM launchers that the United States and the Soviet Union could deploy for the period May 1972 through October 1977.** When it expired, both the U.S. and the Soviet Governments indicated that pending the completion of negotiations for a SALT II Treaty, they would continue to abide by the terms of the Interim Agreement unless or until the other party to that agreement undertook an action that was inconsistent with the terms of that agreement.<sup>5b</sup>

Article I of the Interim Agreement prohibits the construction of additional fixed land-based ICBM launchers after July 1, 1972.<sup>7</sup> Hence if the Interim Agreement were still de facto in effect when the MX was to be deployed, MX basing in silos would be limited to modified Minuteman silos rather than new ones.

<sup>3</sup>“Statement by Secretary of State Vance United States Intent Regarding the SALT I Interim Agreement, September 23, 1977,” in *U S Arms Control and Disarmament Agency, Documents on Disarmament, 1977* (Washington, D C U S Government Printing Office, 1979), pp 577-578

**Secretary of State Vance issued the following statement**

In order to maintain the status quo while SALT I negotiations are being completed, the United States declares its intention not to take any action inconsistent with the provisions of the Interim Agreement on certain measures with respect to the limitation of strategic offensive arms which expires October 3, 1977, and with the goals of these ongoing negotiations, provided the Soviet Union exercises similar restraint

**“Statement by the Soviet Union Intent Regarding the SALT I Interim Agreement, Sept 24, 1977,” Ibid , p 578**

In accordance with the readiness expressed by both sides to complete a new agreement limiting strategic offensive arms and in the interests of maintaining the status quo while the talks on the new agreement are being concluded, the Soviet Union expresses its intention to keep from any actions [compatible with the provisions of the Interim agreement on some measures pertaining to the limitation of strategic offensive arms which expires on October 3, 1977, and with the goals of the talks that are being conducted, provided that the United States of America shows the same restraint

<sup>7</sup>.Interim Agreement, ” in *Arms Control Agreements*, p 150

<sup>3</sup>“Limited Test Ban Treaty, ” art I IN Ibid , p 42

<sup>4</sup>.Interim Agreement on Strategic Of fensive Arms, ” in Ibid , pp 150-157

Modernization of SLBM platforms is specifically permitted under article IV of the Interim Agreement, so deployment of both the Trident submarine and small submarines armed with MX missiles would be allowed were the terms of the Interim Agreement still being observed at the time MX deployment was made.<sup>8</sup>

During the final hours of the SALT I negotiations, Department of Defense (DOD) Representative Paul Nitze spoke for the U.S. Government on the question of land-mobile ICBMS. Nitze said:

**In connection with the important subject of land-mobile ICBM launchers, in the interest of concluding the Interim Agreement the U.S. Delegation now withdraws its proposal that Article I or an agreed statement explicitly prohibit the deployment of mobile land-based ICBM launchers. I have been instructed to inform you that while agreeing to defer the question of limitation of operational land-mobile ICBM launchers to the subsequent negotiations on more complete I imitations on strategic offensive arms, the U.S. would consider the deployment of operational land mobile ICBM launchers during the period of the Interim Agreement as inconsistent with the objectives of that Agreement.<sup>9</sup>**

**The purpose of this statement was to warn the Soviet union that the united States would consider the deployment of the SS-16 in its mobile mode** to be legitimate grounds for terminating the Interim Agreement. It was not intended to preclude U.S. deployment of a mobile ICBM at some future point in time if agreement on measures to ensure adequate verification of a SALT treaty limiting offensive forces could be negotiated.

The Protocol to the Interim Agreement limits to 710 the number of SLBM launchers permitted for the United States. The Protocol further provided that both the United States and the Soviet Union could exchange retiring

ICBMS deployed prior to 1964 for new SLBMs. 'O However, President Nixon informed the Soviet Government that the United States would not exercise its right under the provisions of Article 11 I of the Protocol to convert older ICBMs into newer SLBM launchers.

The number of SLBM launchers deployed by the United States would exceed 710 if deployment of MX missiles on small submarines were to take place, the 31 SSBNS built in the 1960's armed with Poseidon and Trident missiles were retained in the fleet, and more than nine Trident submarines were to be deployed simultaneously. A judgment on the strategic utility of continuing into the late 1980's and 1990's to adhere to the terms of the 1972 Interim Agreement on Strategic Offensive Forces would require considerable technical and political analysis as the number of deployed MX missiles on small submarines, *Trident* submarines, and remaining Poseidon submarines approached the limit of the Interim Agreement.

The second component of the SALT I Agreements relating to MX basing is the 1972 ABM Limitation Treaty discussed in chapter 3. The ABM Limitation Treaty prohibits the deployment of the LoADS ABM system or the present concept of an Overlay ABM to defend MX missiles deployed either in MPS or in silos. It also prohibits the deployment of Soviet defenses that in turn might substantially increase the need for larger numbers of U.S. strategic weapons carried aboard both ICBMS and SLBMS. The value of deploying MX in any mode protected by any ABM system must be weighed against the uncertainties in U.S. strategic planning and increases in strategic forces requirements that might be introduced with the deployment of a Soviet ABM system.

“” Protocol to the Interim Agreement,” in *ibid* , p. 154

‘ The evolution of the limits on the number of modern submarine launched ballistic missile launchers in the SALT I interim Agreement Protocol are discussed in great detail in Gerard C Smith’s book, *Doubletalk: The Story of SALT* (Garden City, N Y Doubleday, 1980) See especially pp 393-397 and p 428

<sup>8</sup>*ibid* , p 151

“Unitateral Statement [B]: Land-Mobile ICBM Launchers, ” *ibid* , p 156

## IMPACT OF SALT II ON MX BASING

The SALT II Treaty, signed June 18, 1979, in Vienna, Austria, would substantially affect MX basing options were the Treaty to be ratified and were its terms to remain in effect beyond December 31, 1985. The Treaty was intended to limit equally the total number of strategic nuclear weapons delivery vehicles in the arsenals of the United States and the Soviet Union, to place an upper limit on the total number of nuclear weapons carried by ICBMS, SLBMS, and long-range bombers equipped with cruise missiles, or air-to-surface ballistic missiles, and to inhibit the development of new types of ICBMS. It was also intended to build confidence in the ability of the two nations to coexist without fear of an unremitting strategic arms race by providing for an exchange of data on strategic nuclear weapons, establishing rules for the monitoring of each other's compliance with the terms of the treaty, exchanging information on certain activities that might be ambiguous, and continuing the negotiating process leading to one or more subsequent Strategic Arms Limitation Agreements.<sup>2</sup>

The Treaty was submitted to the Senate on June 22, 1979, where extensive hearings were held by both the Committee on Foreign Relations and the Committee on Armed Services. Before the Senate could take up the report of the Foreign Relations Committee on the proposed ratification of the Treaty, the Soviet Union invaded Afghanistan and President Carter formally requested the Senate on January 3, 1980, to defer further action on the Treaty. The President said in his letter to Senator Robert Byrd:

**In light of the Soviet invasion of Afghanistan, I request that you delay consideration of the SALT II Treaty on the Senate floor.**

**The purpose of this request is not to withdraw the Treaty from consideration, but to de-**

**fer debate so that Congress and I as President can assess Soviet actions and intentions, and devote our primary attention to the legislative and other measures required to respond to this crisis.**

The United States has signed the Treaty, as has the Soviet Union; however, the Soviet Union has not ratified the Treaty, and has stated that it will not do so until the United States indicates whether or not it will complete the ratification process as is required by the U.S. Constitution. The United States has not completed ratification of the Treaty, since two-thirds of the Senate has not given its advice and consent to do so.

During this period between signature of the Treaty and either its ratification or rejection, common understanding of international law requires the United States to take no action intended to defeat the purposes for which the SALT II Treaty was negotiated.<sup>14</sup> The Reagan administration has publicly taken the position that it does not believe itself bound by the limits of the agreement pending completion of a careful review of the Treaty.<sup>15</sup> Nevertheless, the United States has observed those provisions of the Treaty imposing quantitative and qualitative limitations on American strategic nuclear forces.

<sup>14</sup>"Strategic Arms Limitation Treaty," in *Weekly Compilation of Presidential Documents*, vol. 16, No. 1 (Jan. 7, 1980), p. 12.

<sup>15</sup>"Statement by William J. Perry," in U.S. Congress, Senate Committee on Armed Services, *Department of Defense Authorization for Appropriations for Fiscal Year 1981* (Washington, D.C.: U.S. Government Printing Office, 1980), p. 626.

Under international law a state is obligated to refrain from taking actions which would defeat the object and purpose of a Treaty it has signed subject to ratification until it shall have made its intention clear not to become a party to the Treaty. We, therefore, expect that both the United States and the Soviet Union will refrain from acts which would defeat the object and purpose of the SALT II Treaty before it is ratified and enters into force, and indications are that both sides are doing this.

This obligation however, is not of indefinite duration.  
<sup>15</sup>Bernard Gwertzman, "U.S. Says It Is Not Bound by 2 Arms Pacts With Soviet," *New York Times*, May 20, 1981, reported:

The Reagan Administration affirmed today that it was not legally bound by either of two treaties with the Soviet Union on the limitation of strategic nuclear weapons.

A statement, issued by the State Department . . . said, however, that, pending a policy review, nothing would be done to undercut the accords as long as the Russians also did not undercut them.

<sup>14</sup>See "Letter of Transmittal of the SALT Two Treaty From Secretary of State Vance to President Carter," in U.S. Congress, Senate Committee on Foreign Relations, *SALT Two Treaty, Hearings, Volume 1* (Washington, D.C.: U.S. Government Printing Office, 1979), pp. 4-44.

There are several provisions of the proposed SALT II Treaty that would affect the deployment of the MX were the terms of the Treaty in force in 1986 or beyond. Some of the Treaty provisions affect basing modes directly; other provisions of the Treaty might affect the testing, operation, or cost of MX deployment, or might require design changes in various basing modes to facilitate monitoring the deployment of mobile ICBMS for compliance with the terms of the Treaty.

Four basing modes would be explicitly prohibited under terms of the SALT II Treaty were the Treaty in force when the MX would be deployed:

1. Deployment of MX missiles in new, fixed ICBM silos would be prohibited under provisions of article IV.
2. Surface ship mobile deployment of MX missiles would be prohibited under provisions of article IX.<sup>7</sup>
3. Deployment of MX missiles on inland waterways, lakes, or the bottoms thereof would be prohibited under provisions of article IX.
4. Deployment of MX missiles in any basing mode to launch nuclear weapons into Earth orbit would be prohibited under provisions of article IX.

Article II of the Treaty defines ICBM launchers countable under the Treaty. MX research, development, and test launchers must be unique to the MX missiles unless the United States would be willing to have less capable missiles and their launchers counted under the SALT II limits.<sup>8</sup> For example, mobile intermediate range ballistic missiles would be countable under the SALT II Treaty limits if they were tested from MX development facilities or MX deployment sites.

Deployment of MX missiles by backfitting them into existing Minuteman silos would be permitted under terms of the SALT II Treaty,

<sup>7</sup>"SALT II Treaty," art IV, in *Arms Control Agreements*, p 215.

<sup>8</sup>Art IX, clause I(a), *ibid*, p 225

<sup>9</sup>Art IX, clause I(b), *ibid*

<sup>10</sup>Art IX, clause I(c), *ibid*

<sup>11</sup>Art II, *ibid*, pp 208-214

even if existing Minuteman silos required modification to support the larger MX missile.<sup>2</sup> Deployment of MX missiles to Minuteman II silos would, however, by definition increase the number of MI RV-countable launchers, thereby bringing the United States closer to or even exceeding the allowed number of MIRVed ballistic missiles under provisions of the Treaty.<sup>22</sup>

While the SALT II Treaty permits modernization and improvements of ICBMS and their launchers, there is disagreement between the United States and the Soviet Union as to whether or not multiple protective shelters constitute fixed ICBM launchers within the context of article IV.

The Soviet position is that multiple protective shelters are but one form of fixed ICBM launchers. "

The U.S. position is that so long as the multiple protective shelter cannot launch an MX missile without the aid of an associated launcher that contains launch support equipment including power supplies, environmental control equipment, communications equipment, and other missile support equipment, the shelters would not meet the definition of a fixed ICBM launcher found in article 11 of the Treaty. MPS basing for MX would therefore be permitted were the SALT II Treaty in force when the MX was deployed.<sup>24</sup>

Article XV of the Treaty requires that any deployment of the MX missile be made in a manner that would permit the unimpeded use of technical means of verification to monitor U.S. compliance with the provisions of the

<sup>21</sup>Art IV, *ibid*, pp 214-215

<sup>22</sup>Art V, *ibid*, pp 220-221

<sup>23</sup>The Soviet position on MPS deployment for the MX or Minuteman missiles is described by Strobe Talbott, in "Keeping the Options Open," *Endgame: The Inside Story of SALT II* (New York: Harper & Row, 1979, 1980), p 162-173, on the basis of interviews with senior U.S. officials. Authoritative unclassified discussion of the Soviet position on this issue is presented in, U.S. Congress Senate Committee on Foreign Relations, *SALT II Treaty* (Washington, D.C.: U.S. Government Printing Office, 1979), Part 4, pp 433-437 and Part 5, pp 278-280, 291, 301-302

<sup>24</sup>*Ibid*, see also, "Statement of Ambassador Ralph Earle," in U.S. Congress, Senate Foreign Relations Committee, *ibid*, pt 4, pp 436

SALT II Treaty were the treaty in force at the time the MX was deployed.

Each basing mode for the MX can in principle be designed to meet the requirements of article XV for verification; however, the U.S. deployment of a mobile ICBM will set a standard by which future mobile ICBM deployments by the Soviet Union will be judged. It is therefore important to note that for MPS basing, the key features supporting the monitoring of U.S. compliance with the quantitative limits in article V of the Treaty are (a) open hall construction of the missile and its associated launcher; (b) confinement of deployed missiles to a designated deployment area and (c) use of a dedicated transportation system.<sup>25</sup>

There has been considerable speculation about the differences between horizontal and vertical shelters from the standpoint of SALT II Treaty verifiability. The proposed MX/MPS system has been carefully designed from both engineering and operational standpoints to permit monitoring of the number of MX missiles deployed by the United States without revealing their exact location consistent with the need to preserve location uncertainty—PLU. These design features and operations are described in detail in chapter 2.

On the basis of a review of unclassified discussion of verification problems associated with counting the number of MX missiles deployed by the United States, there appears to be little difference between vertical and horizontal shelters. Monitoring deployment of Soviet mobile ICBMs could be easier or could be carried out more confidently if their mobile ICBMs were deployed in horizontal shelters with removable observation ports. Thus, the requirement that the MX be deployed in a manner that would permit the United States to monitor a similar if not identical Soviet de-

ployment sometime in the future *may* make the distinction between horizontal and vertical shelters significant.

Rebasing Minuteman III missiles in an MPS mode would be constrained were the terms of the SALT II Treaty in force in 1986 when such deployments could begin. The number of Minuteman III missiles that could be deployed would be limited under terms of article V such that the total number of ICBMS and SLBMS equipped with MIRVS could not exceed 1,200, and the total number of bombers equipped with air-launched cruise missiles, MIRVed ICBMS, and MIRVed SLBMS could not exceed 1,320.<sup>26</sup> DOD has proposed to deploy up to 172 B-52 aircraft equipped with air-launched cruise missiles,<sup>27</sup> and as many as **760** MIRVed SLBMS in the late 1980's,<sup>28</sup> leaving room for only 388 MIRVed ICBMS under the proposed ceiling on aggregate number of MIRVed strategic nuclear delivery vehicles in the SALT II Treaty.

Rebasing of Minuteman III missiles could therefore disrupt current plans to deploy a fleet of MIRVed Poseidon and Trident SLBMS, B-52 bombers equipped with air-launched cruise missiles, and retention of the present Minuteman III force. Furthermore, the small number of missiles that could be deployed within the SALT II Treaty limits were they in force beyond 1985 would constrain a Minuteman III/MPS system to a MX of Minuteman III missiles and shelters that would cost considerably more than the optimal mix.

Questions on status of vertical shelters noted above in connection with MX/MPS would also require resolution for rebasing of Minuteman III missiles. Verification issues arising in connection with MX/MPS would also arise in the case of rebasing of the Minuteman III missiles in an MPS mode.

Other basing modes for the MX not explicitly prohibited by the SALT II Treaty do not appear to be as stressful to the monitoring capabilities of either the United States or the

<sup>25</sup>See statement of Dr. James Timbie to the Subcommittee on Public Lands, House Committee on the Interior, *Status of the MX Missile* (Washington, D.C.: U.S. Government Printing Office, 1980), pp. 400-401. See also, U.S. Congress, House Committee on Foreign Affairs and Senate Committee on Foreign Relations, *Arms Control Impact Statements for Fiscal Year 1982* (Washington, D.C.: U.S. Government Printing Office, 1981), pp. 62-67; *ibid.*, *Arms Control Impact Statements for Fiscal Year 1981* (Washington, D.C.: U.S. Government Printing Office, 1980), pp. 58-63.

<sup>26</sup>Art. V, in *Arms Control Agreements*, pp. 220-221.

<sup>27</sup>U.S. Congress, House Committee on Foreign Affairs and Senate Committee on Foreign Relations, *Arms Control Impact Statements for Fiscal Year 1982*, op. cit., p. 125.

<sup>28</sup>*Ibid.*, p. 80.

Soviet Union as MX or Minuteman III deployed in an MPS mode. Silo basing, with or without defense, can be monitored readily by national technical means in the same manner that current deployments of MIRVed ICBMS are monitored. Air-mobile basing of MX could be monitored through national technical means just as present bomber deployments are monitored. In addition, air-mobile deployment of MX if undertaken within the terms of the SALT I I Treaty would require the use of aircraft with Functionally Related Observable Differences (FRODS). Such measures might include the use of specifically designed aircraft unique to the air-mobile MX mission or the structural modification of other aircraft of similar types to aid in their identification as MX missile launching platforms through use of national technical means of verification. These measures would facilitate counting the MX-carrying aircraft and missiles under the aggregate limits on strategic nuclear delivery vehicles and the MI RV-ed ICBM sublimits.

Small submarine basing for the MX missile could be verified relying on the techniques and technologies presently used to count deployed SLBMS.

The SALT II Treaty, were it ratified, would have some effect on the MX basing mode decision, ruling out new ICBM silo basing, surface ship mobile basing, inland waterway basing, and orbital bombardment systems on legal grounds. Other basing modes for the MX missile would be permitted, and with the exception of MPS basing for MX or Minuteman III appear to present few technical challenges to the capabilities of either the United States or the Soviet Union to adequately verify each other's compliance with terms of the proposed SALT I I Treaty were the Treaty still in force in the period 1986 through the 1990's and beyond.

## OTHER PENDING ARMS CONTROL AGREEMENTS AFFECTING MX BASING

Like the 1962 Partial Test Ban Treaty, the 1976 Threshold Nuclear Test Ban Treaty and the 1978 Peaceful Nuclear Explosions Treaty do not directly limit any MX basing decision. These two treaties, still awaiting U.S. ratification, nevertheless impose limits on certain U.S. Government activities that in turn affect research and development activities related to **MX** basing issues.

The Threshold Nuclear Test Ban Treaty limits the yield of underground nuclear explosions to not more than 150 kilotons. 29 In so doing, it limits the ability of the United States to conduct research and development on the structural hardness and resistance to nuclear effects of MPS horizontal and vertical structures, command and control systems, command post structures, and vehicles. The Peace-

ful Nuclear Explosions Treaty limits nuclear explosions for peaceful purposes to a yield of 150 kilotons. It also imposes certain additional limitations on the instrumentation of such explosions intended to reduce the likelihood that a peaceful nuclear explosion might be used to hide either nuclear weapons development activities or tests for various nuclear weapon effects. 30 Hence, these two treaties, like the Partial Test Ban Treaty, limit to some degree the ability of the United States to test the hardness of various MX basing modes to the nuclear effects environment in which they might be required to operate.

It is important to note, however, that the underground nuclear testing program conducted by the U.S. Government in recent years, chemical explosion simulation tests, other dynamic stress tests, nondestructive

<sup>29</sup> "Threshold Test Ban Treaty," in *Arms Control/Agreements*, pp 167-170

<sup>30</sup> "Peaceful Nuclear Explosions Treaty," *Ibid*, pp 173-189

tests, and simulations have provided a wealth of data necessary to design the MX missile and various possible basing modes for it. As a result of "this vigorous test program related to

MX development, there is widespread confidence in the ability of the missile to be built and operated within the design specifications.

## FUTURE ARMS CONTROL NEGOTIATIONS

**It is very difficult to predict confidently the future course of international arms control negotiations.** The recent history of the Strategic Arms Limitation Talks between the United States and the Soviet Union serves to illustrate the multiple technical and political problems confronting would-be arms control negotiators.<sup>1</sup>

However, both the United States and the Soviet Union, despite obvious difficulties in bringing the SALT II Treaty into force, have stated their continuing hope for eventual resumption of arms control negotiations. During ceremonies welcoming Chancellor Helmut Schmidt of the Federal Republic of Germany, President Reagan reaffirmed the commitment of the United States to negotiations leading to the reduction of arms in Europe within the SALT framework. The President promised "meaningful negotiations as to limit those very weapons."

The Soviets too have expressed their continuing desire for a resumption of arms control negotiations. For example, Leonid Brezhnev, General Secretary of the Communist Party of

the Soviet Union, in speaking to the 26th Congress of the Party, said:

**We once more issue an urgent appeal for restraint in the sphere of strategic armaments. The peoples of the world must not be allowed to live under the threat of a nuclear war being unleashed. The limitation of strategic arms and their reduction is an extraordinary problem. On our part, we are ready to continue without delay appropriate talks with the United States of America while preserving everything positive that has been achieved up to now in this sphere.**

The interest of both the United States and the Soviet Union in continuing their bilateral dialog on arms control suggests a need to understand better the impact of the MX basing decision on some of the problems arms control negotiators may face in the future.

MX missiles deployed in silos, on small submarines, or in an air mobile mode present few new arms control negotiating problems. These basing modes are either extensions of existing basing modes for strategic nuclear weapons delivery vehicles (SNDVS) or have been previously considered during the Strategic Arms Limitation Talks.<sup>2</sup> As a result there appear to be few new or unique arms control negotiating or verification problems associated with these basing modes. Extension of past arms control negotiating and verification practices would enable both the United States and the Soviet Union to conclude an arms control agreement

<sup>1</sup>"See for example, testimony of various public officials and private witnesses on the pros and cons of the ratification of the SALT II Treaty in U S Congress, Senate Committee on Foreign Relations, *SALT II Treaty, Volumes 1 Through 5* (Washington, DC: U S Government Printing Office, 1979), U S Congress, Senate Committee on Armed Services, *Military Implications of the SALT II Treaty, Volumes 1 Through 6* (Washington, DC: U S Government Printing Office, 1979) See also Strobe Talbott, op cit., Robert P La brie, *SALT Handbook: Key Documents and Issues, 1971- 1979* (Washington, DC: American Enterprise Institute, 1979) For an interesting account of Soviet views on the problems of negotiating SALT, see Samuel B Payne, Jr., *The Soviet Union and SALT* (Cambridge, Mass: MIT Press, 1980)

<sup>2</sup>"Visit of Chancellor Helmut Schmidt of the Federal Republic of Germany," *Weekly Compilation of Presidential Documents*, vol 17, No 21 (May 25, 1981), p 547 The commitment of the United States to renew arms control efforts was made by Secretary Haig to the NATO Foreign Ministers during his speech of May 4, 1981 See John M Goshko, "Haig Tells NATO of New Plan for Talks With Soviets," *Washington Post*, May 5, 1981

<sup>3</sup>"Proceedings of the 26th CPSU Congress, Volume 1 Brezhnev Report," in *Foreign Broadcast Publication Service, Daily Report: Soviet Union*, vol 111, No 36, Supplement 1, Feb 24, 1981, p 20

<sup>4</sup>"Air-to-surface ballistic missiles and the aircraft carrying them would be a permitted MX basing mode were SALT II in effect in the late 1980's provided the missiles were not tested before the expiration of the Protocol to the SALT II Treaty on Dec 31, 1981, and that the aircraft carrying the missiles were equipped with FRODS to facilitate verification



permitting deployment of the MX missile in one or more of these modes which would still be verifiable using national technical means.

Surface ship mobile deployment of the MX missile, as noted earlier, is prohibited by the terms of the SALT I I Treaty because no formula could be negotiated to permit adequate verification without reducing surface ship mobile ICBM survivability to an unacceptable level. The principal arms control negotiating problem is the development of a formula permitting deployment of surface ship mobile MX in a relatively survivable manner on the one hand, and adequate verification of the number of missiles so deployed on the other. U.S. deployment of a surface ship mobile MX would establish a precedent for Soviet deployment of a comparable system. However, the United States would want to be certain that the ability to count the number of Soviet surface ship mobile ICBMS would not be unduly hindered should the Soviets opt for a mobile ICBM deployed in that mode at some time in the future. The problem from a weapon system survivability perspective is that steps that might be taken to facilitate arms control agreement verification rapidly reduce the survivability of surface ship mobile based ICBMS (see ch. 7 of this report).

**Deployment of MX missiles on surface ship platforms equipped with FRODS to aid verification of an arms control agreement would facilitate detection, identification, and maintenance of trail at sea, thereby reducing survivability to a very low rate.** Limiting areas of surface ship mobile operation would facilitate counting the vessels, but would also permit the Soviets to concentrate their antisurface warfare-monitoring assets on the general areas of deployment, thereby reducing the long-term survivability of the surface ship platforms.

MX missiles deployed in an MPS mode with or without defense would radically alter the arms control negotiating environment.

The number of ICBMS deployed in fixed silos cannot be readily augmented without considerable testing of alternative means for

launching missiles. The time consumed and the highly visible activities involved in the construction of ICBM silos make it highly unlikely that such silos could be deployed in large numbers without being detected by national technical means of arms control agreement verification. Other techniques for launching ICBMS might be developed that would go unnoticed, but such techniques could be detected when and if extensive testing were to occur.

Uncertainty about the possibility of detecting a clandestine deployment of ICBMS makes it difficult for either the United States or the Soviet Union to justify the risks of clandestine ICBM deployment unless such a deployment could be large enough to make a significant difference in the strategic balance. While judgments as to the number of clandestinely deployed ICBMs or RVS will vary among analysts, the threshold for strategic significance diminishes quickly as the number of ICBMS and/or RVS permitted decreases.

MPS deployment by the Soviets for a future land-mobile ICBM might create a situation in which they would find it relatively easy to either openly abrogate or clandestinely violate on arms control treaty limiting the number of land-mobile ICBMS deployed. An MPS system would deploy an entire infrastructure of **missile shelters, command and control systems, transportation systems maintenance facilities, personnel, and other resources needed** to support any mobile ICBM. Rapid, overt deployment of stockpiled missiles ("breakout") in excess of future treaty limitations in a sudden, open act of treaty abrogation might therefore be an attractive, relatively low cost option for increasing Soviet strategic forces.

The existence of the MPS infrastructure might also encourage clandestine attempts to deploy excess land-mobile ICBMS. Such deployments could be especially difficult to detect after they had occurred, and MPS deployment of land mobile ICBMS might lead to a situation in which it would not be possible to adequately verify violation of an arms control agreement.

MX/MPS creates an unprecedented need for future arms control agreements to specify cooperative measures for verifying the number of mobile ICBMS deployed by either side. This subject raises serious negotiating problems, as each procedure related to the verification of the number of MX missiles deployed by the United States must be designed with a hypothetical Soviet mobile ICBM in mind as well. Furthermore, a series of procedures, useful for verification purposes but perhaps not essential, would have to be included in order to ensure that those procedures essential for purposes of counting the number of large, land mobile ICBMs deployed by either side emerge from the negotiating process.

MX deployed in an MPS mode would further complicate the process of strategic arms control negotiation limitation by placing a very high value on Soviet agreement to an RV limitation. Previous SALT negotiations have attempted to balance specific United States and Soviet advantages in various areas of strategic weapons and Strategic nuclear weapon delivery systems in order to conclude an agreement that was balanced. While views differ on the degree of success U.S. and Soviet negotiators have had in attempting to reach a balanced agreement, MX/MPS would further complicate the negotiating process. The great sensitivity of the MX/MPS survivability to the numbers of Soviet RVS and the potential growth in the Soviet RV inventory coupled with the great cost of the United States MPS system would put Soviet arms control negotiators in a very strong negotiating position. An agreement limiting the number of Soviet RVS now or in the future would enable the United States to plan and budget for MX/MPS; the Soviets could therefore use their willingness to agree to RV limitations as a "bargaining chip" to persuade the United States to agree to other limitations on strategic weapons of keen interest to the Soviets.

MX/MPS also complicates arms control negotiations by making it much more difficult to accept any agreement that would freeze strategic force modernization efforts unless such a freeze were absolute. The sensitivity of MX/MPS survivability to the number of RVS de-

ployed by the Soviets would require the United States to take a position that in essence required the Soviets to stop all construction and deployment of systems not operational as of a certain date even though MPS construction would have to continue until the number of shelters built exceeded the number of threatening Soviet RVS. Failure to obtain this kind of cutoff of new deployments would jeopardize the survivability of MX missiles deployed in an MPS mode.

Minuteman III rebased in an MPS mode would similarly complicate future arms control negotiations. Rebased Minuteman III would be as sensitive to the number of Soviet RVS deployed as would be MX/MPS deployment; the relative bargaining leverage gained by the Soviets for MX/MPS would also be gained with Minuteman III/MPS. Cooperative measures for verifying U.S. compliance with a limitation on the number of mobile, relatively small ICBMS would also have to be negotiated, again on the premise that U.S. deployment of a mobile ICBM would at some point be matched by a similar but not necessarily identical Soviet mobile ICBM deployment.

As a result, MX/MPS and Minuteman III/MPS would create a need for arms control negotiations to become ever more deeply and intimately involved in the specification of detailed procedures of weapon system deployment and peacetime operation.

Defended MX/MPS would add the great uncertainties associated with the reopening of discussions on ABM system limitations to the other negotiating problems noted above. While the present ABM Treaty seriously inhibits development, testing, and deployment of the LoADS ABM system, it equally inhibits development and deployment of Soviet ABM systems. Were the Soviets to be relieved of this legal inhibition, they might well deploy an ABM system that would affect the ability of U.S. ICBM and SLBM RVS to successfully attack Soviet targets, generating requirements for significantly larger numbers of U.S. strategic forces. The great uncertainties introduced in calculating the strategic balance, developing requirements for U.S. strategic

forces, and procuring the necessary forces would have to be weighed against the addi-

tional increment of survivability that a LoADS ABM might provide the MX.

## ARMS CONTROL AND STABILITY

Arms control seeks as a general goal to reduce the likelihood of war. Efforts to maintain international stability and control the escalation of severe international crises are therefore often considered an integral component of arms control. The procurement and deployment of strategic forces in a manner that reduces the incentives to continue modernization or procure additional numbers of forces are also thought to be consistent with arms control efforts. The selection of a basing mode for the MX missile may therefore have broader implications for arms control beyond the negotiation of new international agreements.

The deployment of the MX missile in a survivable basing mode is generally thought to be an important adjunct to the management of severe international crises. High confidence by American and Soviet decisionmakers in the survivability of the MX force would minimize incentives for either side to strike first. Survivable basing would allow American decisionmakers to wait out a crisis without resorting to the use of force out of concern that if the MX missiles were not used, they might be preempted and unavailable later during a crisis. Survivable basing for the MX missile would reduce incentives of the Soviet leadership to attempt preemption because they could not be confident of destroying a sufficiently large fraction of the force to effectively limit the ability of the United States to retaliate. Survivable basing would also reduce Soviet incentives to initiate an attack out of fear that the United States would strike first to forestall Soviet preemption.

As noted throughout the earlier chapters of this study, most basing modes for the MX missile would provide survivability when fully deployed; several including small submarine or air mobile MX basing would provide sub-

stantial survivability concurrent with or shortly after initial operating capability. However, in some operational concepts, air mobile basing might create a situation during a crisis in which the Soviets might mistake a widespread, simultaneous launch of MX-carrying aircraft undertaken to enhance survivability as strategic warning of an impending American attack. Such a perception would add instability to a crisis. While there are many other operational concepts for an air mobile force which might overcome this concern, the possibility that the Soviets might perceive the airborne operation of a large fraction of the air mobile MX force as a provocative action during a severe crisis cannot be completely discounted.

As noted above, the selection of a basing mode for the MX missile that added incentives to increase the size of strategic nuclear forces would be inconsistent with the general goals of arms control. Most basing modes for the MX missile assessed in this study satisfy this criterion; MPS with or without the LoADS defense, however, would provide a strong incentive for the Soviets to add to their inventory of RVS. Finally, MX/MPS would make terminating a buildup of U.S. and Soviet strategic forces more difficult than other MX basing modes because the United States could not stop constructing MPS until the number of shelters exceeded the number of RVS in the Soviet inventory that might pose a threat to MX/MPS survivability. The Soviets, on the other hand, might find it difficult to stop adding RVS to their inventory unless they had clear evidence that the United States had halted its MPS construction program. Thus, MPS with or without the LoADS ABM defense would pose the most severe challenges to the long-term ability of the United States to achieve some of its stated arms control objectives.

# APPENDIXES

Appendix A  
LETTER OF REQUEST

TECHNOLOGY ASSESSMENT BOARD  
MORRIS K. UDALL, ARIZ., CHAIRMAN  
TED STEVENS, ALASKA, VICE CHAIRMAN  
EDWARD M. KENNEDY, MASS.      GEORGE E. BROWN, JR., CALIF.  
ERNEST F. HOLLINGS, S.C.      JOHN O. DINGELL, MICH.  
ADLA E. STEVENSON, -      LARRY WINN, JR., KANS.  
ORRIN A. HATCH, UTAH      CLARENCE E. MILLER, OHIO  
CHARLES MCC. MATHIAS, JR., M.D.      JOHN W. WYOLER, N.Y.  
JOHN H. GIBBONS

Congress of the United States  
OFFICE OF TECHNOLOGY ASSESSMENT  
WASHINGTON, D.C. 20510

JOHN H. GIBBONS  
Director  
DANIEL DESIMONE  
Deputy Director

May 8, 1980

Dr. John H. Gibbons  
Director  
Office of Technology Assessment  
Washington, D. C. 20510

Dear Jack :

The Administration has proposed that the United States build and deploy the new MX missile in Utah and Nevada. Although the case for a new strategic missile is understood, the missile basing system remains controversial, and the trade-offs involved remain unclear. In view of the critical importance of MX to the future military security of the United States, the enormous size of the proposed budget, and the tremendous impact which MX deployment may have on the regions where such deployment takes place, Congress as a whole ought to have the best obtainable information and analysis about MX basing. There would be particular value in an assessment which, while drawing upon whatever military and intelligence information is pertinent, would be independent of the Defense Department and the Administration.

We therefore request that OTA prepare and submit to the Board as soon as possible a plan for an assessment of how the MX missile might be based. If this plan indicates that the time and money required for a study are not excessive, we expect to request that the Board approve the initiation of such an assessment.

The study would describe and evaluate the Administration proposal, selected alternatives which the Defense Department has studied, and additional possible basing modes which seem worthy of consideration. Various types of multiple protective structure (MPS) systems, **alternatives to MPS, and alternatives to land-basing** should be addressed.

Specifically, OTA'S evaluation should address the suitability of each basing concept in terms of such issues as technical risk, survivability (including detectability and hardness) , reliability, the time required for deployment, etc. To the extent necessary to evaluate basing systems, the study should also address the projected Soviet threat, and possible Soviet responses to an MX system.

Dr. John H. Gibbons  
May 8, 1980  
Page Two

In order to clarify the trade-offs that must be made in choosing a basing system, the study should address basing proposals in the following contexts:

(1) the peacetime strategic balance, in which U.S. strategic forces should preserve and enhance stability and security; (2) likely future efforts to negotiate arm= control treaties, in which U.S. strategic forces should make such negotiations easier rather than more difficult; (3) a severe crisis or limited war, in which U.S. strategic forces should enhance our ability to manage the crisis and to terminate it on acceptable terms; and (4) a major war, in which U.S. strategic forces should make an enemy regret that he had refused to be deterred.

To the extent necessary for a comparison of basing systems, the study should evaluate the environmental impact of construction and peacetime operation of the various alternatives. The effect which the choice of basing system might have on the effects of war on the civilian population and economy should also be addressed.

The final topic of the study should be an estimate of the cost of the Administration proposal and of any alternatives that appear worthy of serious consideration. We request that you explore the possibility of a cooperative effort between OTA and the Congressional Budget Office, in which CBO would apply their expertise concerning the budgetary impact of choices Congress might make. If such CBO cooperation appears to be likely, it should be reflected in the assessment plan submitted to the Board.

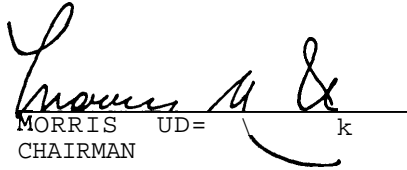
We do not expect or desire that OTA attempt to reach conclusions about whether the Administration proposals, or particular alternatives, should be adopted. The completed assessment should present a clear analysis of the options available to Congress regarding the mx basing, an explanation of why these particular options are worthy of consideration, and a statement of the major advantages and disadvantages of each option.

While OTA should draw upon appropriate classified data regarding both U.S. capabilities and the Soviet threat, the report should contain at least a summary that is unclassified.

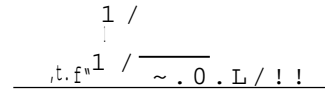
Dr. John H. Gibbons  
May 8, 1980  
Page Three

We recognize that an assessment of this sort cannot be carried out overnight. Nevertheless, timely completion of the assessment is **essential**. The timetable should allow for OTA staff to brief Members of Congress and their staff on the study's preliminary results after the August, 1980 break, and a final report should be ready prior to the convening of the 97th Congress.

With best wishes,

  
MORRIS UDALL  
CHAIRMAN

Cordially,

  
&  
J. F. WELFS  
VICE CHAIRMAN

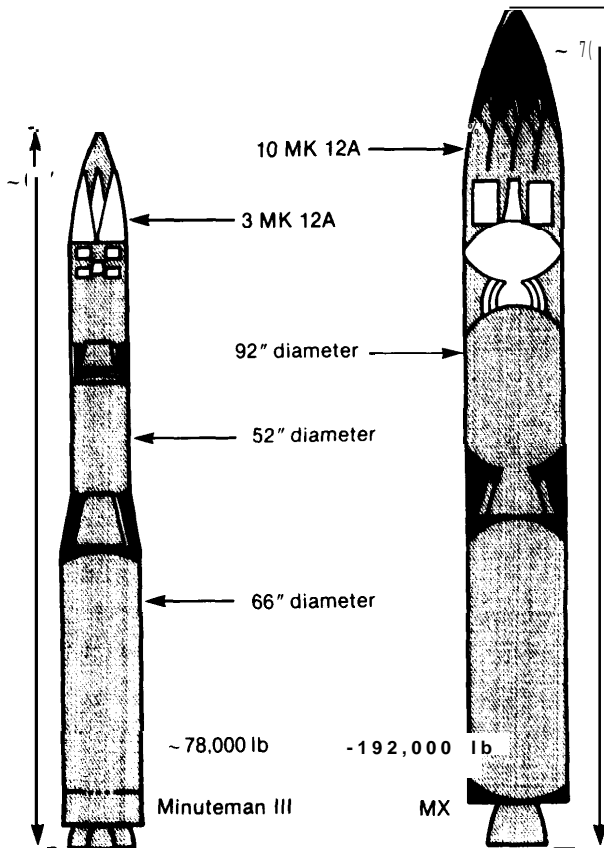
The MX missile is a four stage intercontinental ballistic missile (ICBM) presently in full-scale engineering development. Like its predecessor, the Minuteman III, the first three rocket stages are solid propellant, with a liquid-fueled fourth stage/post-boost vehicle. Weighing about 192,000 lb, the missile will be 70 ft long, with a 92 inch diameter. The MX is a MIRVed (multiple independently targetable reentry vehicle) missile, and will carry 10 MK 12A warheads. The Minuteman III carries three MK 12As. A comparison between the MX and the Minuteman is given in figure B-1.

A drawing of the MX fourth stage postboost vehicle (PBV) is shown in figure B-2. We see that it is designed to be able to carry 12 MK 12A warheads, or alternatively, 11 advanced ballistic reentry vehicles [A BRV). SALT II would limit the number of reentry vehicles (RVS) to 10. The inertial measuring unit (IMI) of the MX'S guidance and control system is a significant advance in guidance technology over Minuteman, and is designed to give the MX much greater accuracy on target.

Also unlike Minuteman, the MX missile will be "cannisterized," to facilitate handling and movement of the missile, and to provide for the missile's environment control. The MX is also designed to be "cold launched" from the cannister. This means that for launch, the missile is first gas-expelled from the cannister, at which point it fires its first stage.

The MX missile is scheduled to begin flight testing in January 1983, for a total of 20 tests before system is in initial operating capability. The last flight test is scheduled for April 1986. These tests will check for a wide variety of missile functions and of associated equipment, including rocket stage performance, guidance and control, reentry system performance, range and payload capability, retargeting, and many others.

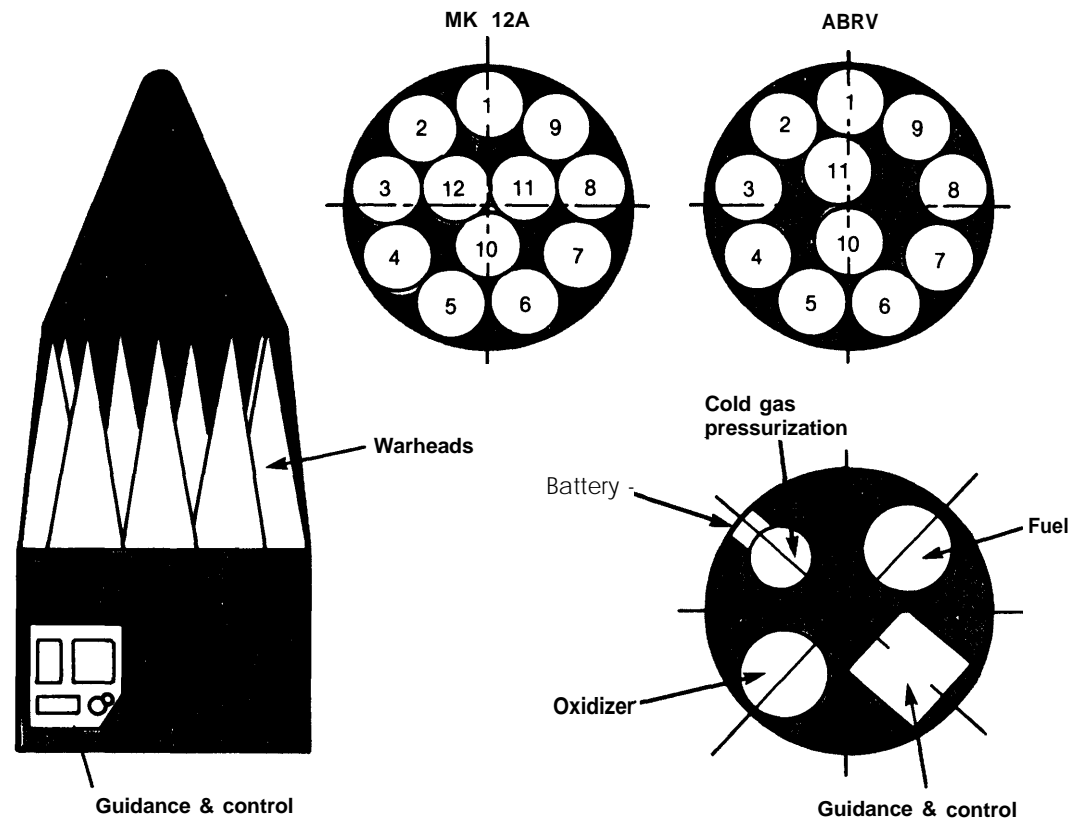
Figure B-1.—Missile Comparison



SOURCE: U.S. Air Force.



Figure B.2.—MX Post Boost Vehicle



SOURCE: U.S. Air Force.

# Appendix C

## ACRONYMS AND GLOSSARY

---

### List of Acronyms

<b>A&amp;CO</b>	— assembly and checkout	<b>LoADS</b>	— low altitude defense system
<b>ABM</b>	— antiballistic missile	<b>LUA</b>	— launch under attack
<b>ABNCP</b>	— Airborne National Command Post	<b>MAP</b>	— multiple aim point
<b>AFY</b>	— acre-feet per year	<b>MaRV</b>	— maneuverable reentry vehicle
<b>AIRS</b>	— Advanced Inertial Reference Sphere	<b>MF</b>	— medium frequency
<b>ALCC</b>	— Airborne Launch Control Center		— square miles
<b>ALCM</b>	— Air-Launched Cruise Missile	<b>;I RV</b>	— multiple independently targetable reentry vehicle
<b>AMST</b>	— Advanced medium short takeoff and landing aircraft	<b>MPS</b>	— multiple protective shelters
<b>ANMCC</b>	— Alternate National Military Command Center (Ft. Richie, Va.)	<b>MT</b>	— megaton
<b>A SAT</b>	— antisatellite	<b>MWe</b>	— megawatts of electricity
<b>ASW</b>	— antisubmarine warfare	<b>NCA</b>	— National Command Authorities
<b>BMD</b>	— ballistic missile defense	<b>NEACP</b>	— National Emergency Airborne Command Post
<b>BMDSCOM</b>	— Ballistic Missile Defense Systems Command (U.S. Army)	<b>NMCC</b>	— National Military Command Center (Pentagon, Washington, D. C.)
<b>C'</b>	— command, control, and communications	<b>nm i</b>	— nautical mile
<b>CBO</b>	— Congressional Budget Office	<b>NORAD</b>	— North American Aerospace Defense Command
<b>CEP</b>	— circular error probable	<b>NTS</b>	— Nevada Test Site
<b>DE IS</b>	— draft environmental impact statement	<b>Occ</b>	— Operational Control Center
<b>DOD</b>	— Department of Defense	<b>ORV</b>	— Off-Road Vehicle
<b>DU</b>	— defense unit (LoADS)	<b>PLU</b>	— preservation of location uncertainty
<b>EAM</b>	— Emergency Action Message	<b>psi</b>	— pounds per square inch
<b>EHF</b>	— extremely high frequency	<b>RDT&amp;E</b>	— research, development, test, and evaluation
<b>EIS</b>	— environmental impact statement	<b>RV</b>	— reentry vehicle
<b>EMP</b>	— electromagnetic pulse	<b>SAC</b>	— Strategic Air Command (U.S. Air Force)
<b>EMT</b>	— equivalent megatonnage	<b>SALT</b>	— Strategic Arms Limitation Talks
<b>FOC</b>	— full operational capability	<b>SATCOM</b>	— Satellite communications
<b>FROD</b>	— functionally related observable difference	<b>ScC</b>	— Standing Consultative Commission
<b>GBS</b>	— Ground Beacon System	<b>SHF</b>	— super high frequency
<b>GPS</b>	— Global Positioning System	<b>SIOP</b>	— Single Integrated Operational Plan
<b>HF</b>	— high frequency	<b>SLBM</b>	— submarine-launched ballistic missile
<b>ICBM</b>	— intercontinental ballistic missile	<b>SWFLANT</b>	— Strategic Weapons Facility, Atlantic, U.S. Navy
<b>ICT</b>	— intelligence cycle time	<b>SWFPAC</b>	— Strategic Weapons Facility, Pacific, U.S. Navy
<b>IGPS</b>	— Inverted Global Positioning System	<b>TEL</b>	— transporter-erector-launcher
<b>IMU</b>	— inertial measuring unit	<b>UHF</b>	— ultrahigh frequency
<b>loc</b>	— initial operating capability	<b>USAF</b>	— U.S. Air Force
<b>KT</b>	— kiloton	<b>USN</b>	— U.S. Navy
<b>LF</b>	— low frequency	<b>VLF</b>	— very low frequency

## Glossary

- ABM Treaty:** Formally entitled the “Treaty between the United States of America and the Union of Soviet Socialist Republics on the limitation of antiballistic missile systems,” this Treaty limits the deployment of antiballistic missile systems by the United States and the Soviet Union to specific sites and to specific technical characteristics. The Treaty is of unlimited duration, subject to review every 5 years. The Treaty was amended in 1974 limiting the deployment of antiballistic missile systems to one site containing no more than 100 interceptor launchers and missiles.
- Acoustic Transponders:** Navigation aids attached to the ocean floor which when queried respond by emitting a signal permitting a submarine or surface ship to determine its location with great precision.
- Acquisition Costs:** The amount of money invested in research, development, test, production, and procurement of a weapon system but not covering costs of operating and maintaining the weapon system once it has reached operational capability and is deployed with military forces.
- Adaptive Preferential Defense:** A tactic for multiplying the effectiveness of an antiballistic missile defense system by defending only a small proportion of the total number of targets under attack.
- Ad Hoc Retargeting:** The ability to construct strategic nuclear attacks which have not been previously included in the wide range of pre-planned attack options comprising the U.S. Single Integrated Operational Plan.
- Advanced Inertial Reference Sphere (AIRS):** An advanced guidance system presently being developed for the MX missile.
- Airborne Launch Control Center (ALCC):** Aircraft used to launch MX missiles deployed in a multiple protective shelter basing mode.
- Air-Launched Cruise Missiles (ALCM):** Small unmanned airplane-like vehicles armed with nuclear weapons.
- Alert Rate:** The number of U.S. strategic nuclear delivery vehicles armed, manned, or deployed on combat patrol during peacetime conditions.
- Antisubmarine Warfare (ASW):** Methods of warfare utilizing specialized sensors, data processing techniques, weapons platforms, and weapons intended to search for, identify, and destroy submarines.
- Area Kill:** See Barrage Attack.
- Arms Control Agreement Verification:** The process of collecting and analyzing information to determine whether or not parties to an international arms control agreement are complying with its terms.
- B-52:** A heavy intercontinental range strategic bomber deployed by the United States. B-52 bombers can be equipped with gravity bombs, short-range attack missiles, or air-launched cruise missiles.
- Ballistic Missile Defense (BMD):** Systems for defense against missiles which follow trajectories resulting from gravity and aerodynamic drag following termination of powered flight. This term is used interchangeably with ABM systems.
- Barrage Attack:** An attack using nuclear weapons to cover a large area with a given severity of blast and/or thermal nuclear effects.
- Baseline Design:** As used in this study, the term “baseline design” refers to the Air Force MX basing design, May 1981. This design includes both the design of the MX missile as well as the multiple protective shelter basing mode.
- Blackout:** A condition in which the heat and radiation from an atmospheric nuclear explosion ionize the surrounding volume of air causing radar signals passing through the affected region to be absorbed or reflected.
- Breakout:** As used in connection with discussion of the LoADS ABM system, breakout refers to the rapid deployment of the LoADS defense unit by use of explosive charges to break through the top of the protective shelter permitting the defense unit to activate its radar and launch its interceptor missiles.
- Circular Error Probable (CEP):** A measure of the accuracy with which a weapon can be delivered. It is the radius of a circle around a target of such size that a weapon aimed at the target has a 50-percent probability of falling within the circle.
- Cold launch:** The use of a gas generator to build up steam pressure inside a cannister housing a ballistic missile which forces the missile out of the cannister prior to the ignition of the first stage rocket motor. The temperature of the steam used to eject the missile from the cannister is quite hot; however it is substantially less than the many thousand degrees Fahrenheit of the rocket motor exhaust, and hence the term “cold launch.”
- Command, Control, and Communications (C<sup>3</sup>):** The systems and procedures used to ensure that the President, senior civilian and military officials, and U.S. strategic nuclear forces remain in com-

- munication with each other, able to plan for the use of nuclear weapons, to choose among options, to deliver orders to the forces in the field, and to receive word that the forces have executed or attempted to execute their orders during the course of peacetime or wartime operations.
- Damage Expectancy:** The probability that a nuclear weapon will arrive at and destroy its target.
- “Dash-on= Warning”:** A concept in which MX missiles on vehicles are dispersed rapidly upon receipt of warning that an attack appears underway to a nearby shelter where the MX missile is quickly inserted.
- Desertification:** The significant reduction of biologic activity and accelerated deterioration of soils in arid land ecosystems.
- Dynamic Pressure:** A measure of the gusting winds following the shock front produced by a nuclear detonation.
- Emergency Action Message (EAM):** Orders to U.S. strategic offensive forces for the initiation or termination of a strategic nuclear attack.
- Electromagnetic Pulse (EMP):** A sharp pulse of electromagnetic energy produced by a nuclear explosion capable of damaging unprotected electrical and electronic equipment at great distances.
- Endoatmospheric Defense:** ABM systems which operate in the sensible portion of the Earth’s atmosphere, typically at altitudes from the ground to 100,000 ft.
- Environmental Impact Statement (EIS):** A description of the possible range of impacts on the socioeconomic and physical environments prepared by the Air Force pursuant to the requirements of the National Environmental Policy Act.
- Endurance:** The ability of a strategic weapons force— including both strategic nuclear weapon delivery vehicles and associated command, control and communications systems — to survive and function for weeks or months following a nuclear exchange.
- Equivalent Megatonnage:** The yield of a nuclear weapon in megatons, to the two-thirds power. A measure of the area that can be barraged to a given overpressure.
- Exchange Ratio:** The number of nuclear weapons that must be used by an attacker to destroy one nuclear weapon belonging to an adversary.
- Exoatmospheric Defense:** ABM systems that operate outside the atmosphere.
- External Navigation Aid:** Devices external to a missile or platform used to provide information to the missile or missile platform on its position and velocity.
- Flush:** A launch of manned aircraft or a rapid deployment of submarines or surface ships in response to either tactical or strategic warning to preserve as much of the force as possible in the event of a nuclear attack.
- Fractionation:** The division of the payload of a missile into a larger number of warheads with smaller individual yields.
- Fugitive Dust:** Dust generated by construction activities and vehicular traffic on and off roads which migrates from the area immediately surrounding such activities to distant locales.
- Full Operational Capability (FOC):** The date on which the planned number of weapon systems has been deployed and control of the forces given to the operational military command for the entire force.
- Functionally Related Observable Differences (FRODS):** Structures added to similar airframes or naval vessels to differentiate among them thereby facilitating direct observation by national technical surveillance systems permitting verification of each party’s compliance with the terms of an arms control agreement.
- Global Positioning System (GPS):** A system of artificial satellites currently being deployed by the United States in the 1970’s and 1980’s intended to provide accurate position and velocity data to facilitate improved navigation and missile accuracy.
- Hardness:** A measure of the resistance of an object to the effects of nuclear detonations.
- Hard Targets:** Targets that have been specifically designed to withstand the blast, thermal radiation, and other effects of nuclear weapon detonations nearby.
- Horizontal Shelters:** Protective shelters for the MX missile constructed such that the missile and its launch support equipment are inserted into the structure and stored in a horizontal position.
- Inertial Guidance:** A guidance system for missiles, aircraft, and ships which relies solely on a self-contained set of instruments carried aboard the platform to determine changes of velocity and position from a known initial point.
- Inertial Measuring Unit (IMU):** A device installed in the uppermost stage of a ballistic missile used to derive missile accelerations throughout flight, and to obtain velocity and position data which is used to navigate the missile.
- Initial Operating Capability (IOC):** The date on which a small number of weapon systems is turned

- over to the commander of a military force for incorporation into the operational forces of the United States.
- Intelligence Cycle Time (ICT):** The period of time from the sighting of a target to the time weapons can be delivered against it.
- Inverted Global Positioning System (IGPS):** A concept for a system of ground-based radio beacons to be used to provide navigational information for mobile MX missiles and various platforms carrying such missiles.
- Kill Vehicles:** Independently guided nonnuclear weapons that are used in the exoatmospheric antiballistic missile systems to destroy incoming nuclear weapons.
- Kilofeet:** 1,000 ft.
- Knot:** 1 nautical mile per hour.
- Kilotons (kT):** Equivalent to 1,000 tons of TNT.
- Launch Under Attack (LUA):** A doctrine for strategic forces requiring their launch upon receipt of warning of an attack on the United States.
- Layered Defense:** An antiballistic missile system consisting of both an exoatmospheric defense and an endoatmospheric defense.
- Lifecycle Costs:** Costs of research, development, test, procurement, operation, maintenance, modification, and dismantling of a weapon system over the period from initial research and development to retirement or dismantling of the last weapon system.
- Low Altitude Defense System (LoADS):** A system proposed by the Army as an endoatmospheric antiballistic missile defense.
- LoADS Defense Unit (DU):** This consists of a radar, interceptor launchers, and interceptors mounted on a mobile unit and deceptively deployed in conjunction with MX missile deployments.
- Maneuvering Reentry Vehicle (MaRV):** An independently targetable reentry vehicle which can maneuver to evade ballistic missile defense or to obtain better accuracy.
- Microwave Radiometers:** Instruments that can detect electromagnetic emissions such as radio transmissions or radar signals used to detect and identify the transmitting platform.
- Minuteman:** An ICBM deployed by the United States in two models. Minuteman II is a three stage, solid fueled missile armed with a single nuclear weapon; Minuteman III is armed with three independently targetable nuclear weapons.
- Multiple Aim Point:** A term for basing a force of ICBMS among a larger number of protective missile shelters. See *Multiple Protective Shelter*.
- Multiple Protective Shelter (MPS):** A term describing a basing mode for land-based missiles in which missiles are deployed among a large number of hardened structures. These are designed and distributed to provide protection against near-by nuclear weapon detonations.
- MX Missile:** Missile X or missile experimental; the proposed U.S. Air Force advanced ICBM.
- Northern Minuteman Wings:** Minuteman missiles deployed at Malstrom Air Force Base, Mont.; Grand Forks, N. Dak.; Warren Air Force Base, Wyo.; and Ellsworth Air Force Base, S.Dak.
- National Technical Means of Verification (NTM):** Technical intelligence information collection systems which are under national control for monitoring compliance with the provisions of an arms control agreement. NTM include photographic reconnaissance satellites, aircraft based systems such as radars and optical systems, as well as sea- and ground-based systems such as radars, antennas for collecting telemetry, and seismic recorders,
- National Command Authorities (NCA):** The President, the Secretary of Defense, and the Joint Chiefs of Staff and their designated successors authorized to initiate an order for the use of nuclear weapons.
- National Emergency Airborne Command Post (NEACP):** A modified Boeing 747 transport aircraft equipped with a wide array of communications equipment for use by the President and other members of the National Command Authorities in the event of a nuclear war.
- Nevada Test Site (NTS):** A facility where the United States detonates nuclear explosive devices underground.
- North American Aerospace Defense Command (NORAD):** A joint U.S.-Canadian military command responsible for outer space, air space surveillance and air defense of the North American Continent.
- Ocean Mobile Systems:** Basing of the MX missile by deploying the missile aboard small submarines or surface ships.
- Operational Control Center (OCC):** Peacetime operating base for logistic support and physical security for the MX missile force.
- Overlay:** concept for exoatmospheric antiballistic missile defense.
- Overpressure:** The transient pressure, usually expressed in pounds per square inch, exceeding the ambient atmospheric pressure, due to the shock wave generated by an explosion.

- Permeable Metal:** A metal with a strong magnetic response.
- Point Kill:** The destruction of a hardened target at a fixed location.
- Postattack:** The period of time following a nuclear exchange between the United States and the Soviet Union.
- Preattack:** The period of time preceding a nuclear exchange between the United States and the Soviet Union.
- Preservation of Location Uncertainty (PLU):** The engineering of the MX missile, its transporter-launcher vehicle, the protective shelter, to prevent an outside observer from determining the precise location of the MX missile among the many available shelters which could house it.
- Rad:** A unit of absorbed dose of radiation.
- Reentry Vehicle:** That portion of a ballistic missile which carries the nuclear weapon and reenters the Earth's atmosphere to reach its target.
- Refit:** The resupply of naval vessels with fresh food, fresh water, fuel, other consumables, installation of new equipment, repair of equipment on board, and the embarkation of a new crew.
- Reliability:** The ability of a missile system to carry out an order from its receipt to the detonation of a weapon against its target.
- Responsiveness:** A measure of the length of time required for U.S. strategic forces to receive, authenticate, and implement an order from the National Command Authorities for the use of nuclear weapons.
- Retargeting:** The process of assigning new targets for a strategic nuclear weapon delivery vehicle.
- Readable TEL:** A missile-carrying vehicle chosen for a previous U.S. Air Force MPS design, that could transport, erect to a vertical position, and launch the MX missile.
- Reentry Vehicles (RV):** As used in this report, reentry vehicles contain nuclear weapons.
- SAFEGUARD:** An antiballistic missile system deployed by the United States in the early 1970's containing both large and small phased array ABM radars and exoatmospheric and endoatmospheric interceptors.
- SALT:** An acronym for the bilateral negotiations between the United States and Soviet Union on the subject of Strategic Arms Limitation Talks. SALT I refers to the agreements concluded in May 1972 including the ABM Treaty and the interim Agreement on Strategic Offensive Nuclear Weapons.
- SCC:** The joint U.S.-U.S.S.R. Standing Consultative Commission, a deliberative and negotiating body established by the ABM Limitation Treaty which meets semiannually to review implementation of the ABM Limitation Treaty and other Strategic Arms Limitation Agreements in force.
- Shock Front:** The leading edge of a wave of air pressure created by an explosion.
- Shoot-Look-Shoot:** A tactic for attacking MX deployed in an MPS or defended MPS mode in which the attacker fires a salvo of reentry vehicles, observes the effects of such an attack, and then attacks shelters left undamaged by the first attack.
- Silo:** A fixed, vertical structure housing an ICBM and its launch support equipment including power supply, communications equipment, and environmental control equipment which has been constructed to withstand the effects of nearby nuclear explosions.
- Single Integrated Operational Plan (SIOP):** The preplanned nuclear attack options prepared for the consideration of the President by the Department of Defense.
- Site Activation Task Force:** A Joint U.S. Air Force and U.S. Army team which will check out and accept individual MPS shelters when the construction contractor believes construction has been completed.
- Small Submarine Basing:** A basing concept utilizing submarines displacing 2,500 to 2,800 tons on which MX missiles are deployed and operated in deep ocean waters within 1,000 to 1,500 miles from the continental United States in the North Atlantic or Gulf of Alaska. The concept as used by OTA differs in several respects to the "small sub underwater mobile" (SUM) basing concept advanced by Sidney Drell and Richard Garwin.
- Smallsub Underwater Mobile (SUM) Basing:** A concept for the deployment of MX missiles on small submarines proposed by Sidney Drell and Richard Garwin.
- Split Basing:** As used in this report, split basing refers to the construction of multiple protective shelters for the MX missile in two regions of deployment. One half of the MX force would be deployed in portions of Texas and New Mexico and the other half of the force would be deployed in Nevada and Utah.
- Sprint:** A very high acceleration, nuclear-armed endoatmospheric ABM interceptor missile deployed by the United States in the early 1970's as part of the SAFEGUARD ABM system.
- SSBN:** Designator of nuclear-powered, fleet ballistic, missile-carrying submarines deployed by the United States, the Soviet Union, France, and the United Kingdom.

- Star Tracker:** A device carried aboard a ballistic missile used to obtain information on the position and orientation of the missile in relationship to a known star for purposes of improving in-flight guidance and the accuracy with which a reentry vehicle could be delivered against a target.
- Strategic Triad:** The three different types of platforms used by the United States to deliver strategic nuclear weapons: ICBMS, submarines carrying SLBMS, and bombers carrying gravity bombs, short-range attack missiles, and long-range air-launched cruise missiles.
- Submarine-launched Ballistic Missile (SLBM):** A ballistic missile carried in or attached to and launched from a submarine.
- SUM:** An acronym for Smallsub Underwater Mobile basing for MX proposed by Sidney Drell and Richard Garwin,
- Transporter-Erector-launcher (TEL):** A vehicle designed for an earlier version of MPS basing which would have been used to transport the MX missile, erect it to a vertical position, and then launch it.
- Time-on-Target Control:** The ability to control the time at which several nuclear weapons arrive at a particular target.
- Transattack:** The period of time in which the United States and the Soviet Union are actively engaged in the exchange of nuclear weapons. This can be a period of minutes or can extend for hours or even days,
- Transporter-** A vehicle designed to transport the MX missile or a mass simulator, and to perform an exchange of either missile or the mass simulator and a protective shelter.
- Trident Missile:** A modern submarine launched ballistic missile deployed by the United States. The Trident I missile is currently being produced and deployed; the Trident II would be a larger and more accurate missile proposed for initial deployment in the late 1980's.
- Trident Submarine:** A very large nuclear-powered, ballistic missile-carrying submarine being deployed by the United States.
- Valley Cluster Basing:** A variant of MPS basing for the MX missile in which missiles may be moved freely among the protective shelters in an entire valley as opposed to only within a cluster.
- Vertical Shelters:** Protective shelters for the MX or Minuteman missile resembling ICBM silos, housing the missile and its mobile launch support equipment in a vertical position.
- Warning Systems:** Satellites, ground-based radars, and other mobile sensors used to provide the United States warning of an impending ICBM, SLBM, or bomber attack.
- Yield:** The energy released in an explosion. The energy released in the detonation of a nuclear weapon is generally measured in terms of the kilotons or megatons of TNT required to produce the same energy release.

## O