

Mission of Daring: The General-Purpose Heat Source Radioisotope Thermoelectric Generator

Gary L. Bennett* and James J. Lombardo†
(formerly of the U.S. Department of Energy and NASA)

Richard J. Hemler‡ and Gil Silverman§
(formerly of Lockheed-Martin Space Systems Company)

C. W. Whitmore¶
(formerly of General Electric Company)

Wayne R. Amos# and E. W. Johnson**
(formerly of Mound Laboratory)

Alfred Schock††
(formerly of Orbital Sciences Corporation)

Roy W. Zocher‡‡ and Thomas K. Keenan§§
(formerly of Los Alamos National Laboratory)

James C. Hagan¶¶
(formerly of Johns Hopkins University Applied Physics Laboratory)

Richard W. Englehart##
(formerly of NUS Corporation; now with the U.S. Department of Energy)

The general-purpose heat source radioisotope thermoelectric generator (GPHS-RTG), which was most recently flown on the New Horizons mission to Pluto, was originally conceived in 1979 and executed in a crash program to replace another RTG for the planned International Solar Polar Mission (ISPM). ISPM would later morph into the Ulysses mission to explore the polar regions of the Sun. When the benefits of the GPHS-RTG technology became apparent, the Galileo program also adopted the GPHS-RTG as the power source for orbital exploration of Jupiter. The GPHS-RTG then became the power source of choice for the Cassini mission to Saturn. The GPHS-RTG was designed such that it could produce 300 We at fueling with a mass of 55.9 kg, making the GPHS-RTG the most powerful RTG with the highest specific power ever flown.

* 5000 Butte Road; Emmett, Idaho 83617-9500; Fellow

† 10816 Longmeadow Drive; Damascus, Maryland 20872-2241

‡ 62 Skyline Drive; Audubon, Pennsylvania 19403; Associate Fellow

§ 1425 Candlebrook Drive; Dresher, Pennsylvania 19025

¶ 111 Deerfield Road; Broomall, Pennsylvania 19008-2036

1178 Brindlestone Drive; Vandalia, Ohio 45377-3100

** 1017 Glen Arbor Court; Centerville, Ohio 45459-5421

†† 7912 Park Overlook Drive; Bethesda, Maryland 20817

‡‡ 24062 Seatter Lane; Kingston, Washington 98346

§§ 289 Venado Street; Los Alamos, New Mexico 87544-2433

¶¶ 12646 Golden Oak Drive; Ellicott City, Maryland 21042

13830 Dufief Mill Road, Gaithersburg, Maryland 20878

1. Introduction

The General-Purpose Heat Source Radioisotope Thermoelectric Generator (GPHS-RTG) has been one of the most successful RTG designs ever flown. Originally conceived to power what was then the International Solar Polar Mission (ISPM; later the Ulysses mission), GPHS-RTGs went on to power the Galileo mission to Jupiter, the Cassini mission to Saturn, and, most recently, a GPHS-RTG is powering the New Horizons mission to Pluto. Figures 1 – 4 are artists' conceptions of these four spacecraft showing their GPHS-RTGs. Mission information has been taken from the Web sites maintained by NASA, the Jet Propulsion Laboratory (JPL), the Johns Hopkins University Applied Physics Laboratory (JHU/APL), the European Space Agency (ESA), and the National Space Science Data Center <<http://nssdc.gsfc.nasa.gov/>>.

Following the successful launches of the two Voyager spacecraft in 1977, the U.S. Department of Energy (DOE) turned its focus toward a new thermoelectric conversion technology that used a selenide-based material. A design for the selenide-based RTG was developed and engineering hardware was built. The new RTG was to power NASA's planned International Solar Polar Mission and the planned Jupiter Orbiter Probe. [ISPM would later morph into a single spacecraft called Ulysses that was built by the European Space Agency (ESA). The Jupiter Orbiter Probe mission would be renamed the Galileo mission.] Both missions were to be launched on the then (in 1979) untried Space Shuttle. Since both multi-year missions involved sending spacecraft to Jupiter with its limited insolation, its cold temperatures (~130 K) and its deadly radiation belts, NASA and ESA needed nuclear power sources. Subsequent testing of the selenide thermoelectric material showed serious problems which ruled it out as being suitable for long-term missions.

DOE was forced to take a number of rapid and dramatic actions. Flight spares of the Multi-Hundred Watt RTG (MHW-RTG) that had been successfully flown on Voyagers 1 and 2 and on the two U.S. Air Force (USAF) communications satellites LES 8/9 (Lincoln Experimental Satellites 8 and 9) were modified for use on the Galileo spacecraft. Meanwhile, the joint NASA-ESA ISPM team requested a new, larger, more powerful RTG (called the ISPM RTG) for their spacecraft.^{1,2} (ISPM originally was conceived as two spacecraft, one to be built by NASA and one to be built by ESA.) When the Galileo project saw the benefits of the planned ISPM RTG they requested two for the Galileo spacecraft. As a result the ISPM RTG was renamed the GPHS-RTG.

The entire GPHS-RTG program was managed and run on a top-priority basis.³ Even though the GPHS-RTG used the same silicon-germanium alloy thermoelectric units (termed "unicouples") as had been successfully used in the MHW-RTG program, the converter housing was new (aluminum type 2219-T6 alloy forging instead of the MHW-RTG beryllium material) and the heat source was new (the modular general-purpose heat source instead of the MHW-RTG integral heat source with its fuel sphere assemblies). Because production of the unicouples had been stopped after the Voyager program there was a need to restart production, this time at General Electric (later Lockheed-Martin) instead of at RCA. To compound the problem, the new heat source required an extensive engineering and safety qualification program. Additionally, DOE had decided to move the RTG assembly and testing work from its RTG contractors to DOE's Mound Laboratory which necessitated a rapid buildup of the infrastructure (people and facilities) at Mound.⁴ (For New Horizons, the most recent GPHS-RTG mission, DOE decided that to enhance safeguards and security following 9/11, it was more cost effective to move the RTG assembly and testing work from Mound to the Idaho National Laboratory (INL). The New Horizons RTG "build" had its own set of exciting challenges.⁵)

Meanwhile, the Galileo and Ulysses missions were being redesigned and launch dates changed. All of this had an impact on the design (e.g., dealing with different launch vehicles) and on the production (as the deliverables and dates changed). Fortunately, a team of hundreds of dedicated people at GE, DOE laboratories and DOE support contractors were able to overcome the numerous hurdles to deliver the required four flight GPHS-RTGs to the Kennedy Space Center (KSC) in time for the originally planned 1986 launches of Galileo and Ulysses. The GPHS-RTG program was truly "a mission of daring". Similar mission changes challenged the GPHS-RTG production teams for Cassini and New Horizons.^{5,6}



Figure 1. Galileo spacecraft in orbit about Jupiter. One of the two GPHS-RTGs shown at the top. (NASA/JPL)

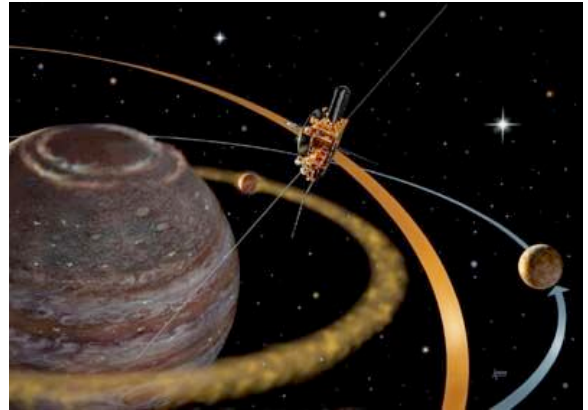

Figure 2. Ulysses spacecraft in its flyby of Jupiter. (Single RTG shown at top.) (ESA)

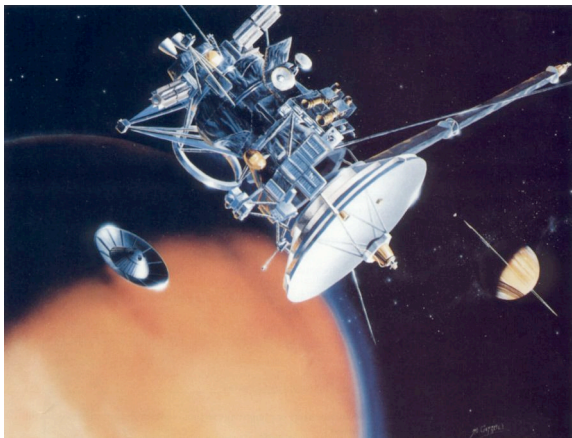

Figure 3. Cassini spacecraft and Huygens probe shown over Titan, Saturn's largest moon. Two of the three GPHS-RTGs are shown near the top of the figure. (NASA/JPL)



Figure 4. New Horizons spacecraft shown flying by Pluto with satellite Charon in the background. The single GPHS-RTG is shown mounted on the left side of the spacecraft. (JHU/APL and SwRI)

2. GPHS-RTG Description

The General-Purpose Heat Source Radioisotope Thermoelectric Generator (GPHS), shown in Figure 5, is composed of two main elements: the general-purpose heat source (GPHS) assembly and the converter. The GPHS assembly consists of 18 modules, each containing four fueled clads that combined (using fresh fuel) produce about 245 Wt per module for a total of about 4410 Wt which the converter with its 572 silicon-germanium (SiGe) alloy thermoelectric elements converts into at least 285 We at beginning-of-mission (BOM). (At the time of fueling, the GPHS-RTG is capable of producing ≥ 300 We.)⁷⁻¹¹

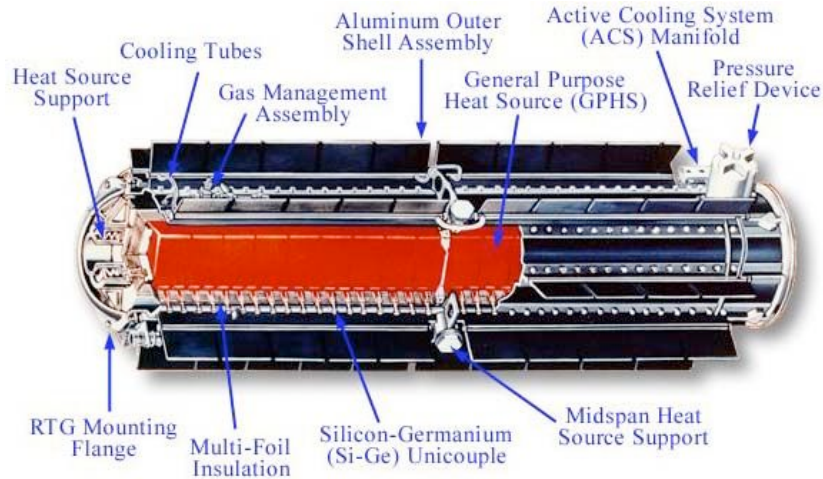

Figure 5. Cutaway of the General-Purpose Heat Source Radioisotope Thermoelectric Generator.
(Galileo/Ulysses version) (DOE/NASA/JPL)

The GPHS-RTG has an overall diameter of 0.422 m and a length of 1.14 m with a mass of about 55.9 kg (Galileo/Ulysses). For the originally planned May 1986 launches of Galileo and Ulysses, the power requirement for the Galileo mission was to provide at least 510 We with two GPHS-RTGs at 4.2 years (36,800 h) after BOM while the power requirement for the Ulysses mission was to provide at least 250 We with one GPHS-RTG at 4.7 years (41,200 h) after BOM. The Galileo, Cassini and New Horizons RTGs were to operate at 30 V and the Ulysses RTG was to operate at 28 V. As a result of the launch delays following the Challenger accident and the concomitant changed mission trajectory the power requirement for the Galileo RTGs was changed to 470 We (235 We per RTG) at end-of-mission (EOM) (71,000 h after BOM). In the case of Ulysses the power requirement was changed to 245 We after 42,000 h.¹¹ The combined Cassini GPHS-RTGs were to provide 826 We at BOM and 596 We at 16 years after launch.⁶ For New Horizons, which is using mostly 21-year-old fuel, the BOM power requirement was 237 We.^{5,12,13} At 9.5 years after BOM (Pluto encounter) the power requirement is 191 We (minimum). (New Horizons is scheduled to encounter the Pluto-Charon system in July 2015 followed by Kuiper Belt Object encounter(s) in the period 2016 to 2020.)

The Cassini RTG program originally began in 1991 with the objective of providing two GPHS-RTGs for each of the following two missions: CRAF (Comet Rendezvous-Asteroid Flyby) and Cassini (the Saturn Orbiter/Titan Probe) plus a common spare (one unfueled electrically heated thermoelectric generator, ETG, and one fueled RTG remained from the Galileo/Ulysses program) for launch in August 1995 (CRAF) and April 1996 (Cassini). In 1992, NASA canceled the CRAF mission and delayed the launch of Cassini. The GPHS-RTG program was subsequently redirected to provide two new ETGs (E-6 and E-7) for conversion to RTGs and to fabricate but not to assemble a third ETG.⁶ (The ETG E-8 would subsequently be fueled to become F-8 and used on the New Horizons spacecraft.) Some changes to the basic design were made for each mission (e.g., modifying the pressure relief device for Cassini and changing the heat source aeroshell geometry for New Horizons); therefore, the interested reader is encouraged to consult the relevant design documents for specific engineering details on each mission's RTGs.

For reference purposes, the Galileo Orbiter used Flight Units F-1 (~289 We) and F-4 (~288 We); the Ulysses spacecraft used Flight Unit F-3 (~289 We); the Cassini spacecraft used Flight Units F-2 (~296 We), F-6 (~294 We), and F-7 (~298 We); and the New Horizons spacecraft used Flight Unit F-8 (245.7 We at the power bus). (Unless otherwise indicated, the numbers in parentheses are the BOM powers at the connector pins.) Flight Unit F-5 was a spare from the Galileo and Ulysses program and was considered as a backup for use on the Cassini spacecraft. With the successful launch of Cassini, F-5 was subsequently defueled with some of its 21-year-old fuel (52 fueled clads) plus new fuel (20 fueled clads) from Russia going into F-8 for the Pluto mission.^{5,11,13}

2.1 GPHS-RTG Converter

The GPHS-RTG converter consists of a thermopile inside an outer shell. The thermopile consists of 572 thermoelectric elements termed “unicouples”, multifoil insulation, and an internal frame. The design of the GPHS-RTG thermopile is based on the design of the MHW-RTG thermopile although the GPHS-RTGs are smaller in diameter; however, the GPHS-RTGs are about twice as long as the MHW-RTGs and they have almost twice the number of unicouples such that they generate almost twice the power of the MHW-RTGs.

The unicouples, shown in Figure 6, are individually fastened to the outer shell. The two silicon-germanium (SiGe) alloy legs of the couple and their corresponding sections of the silicon-molybdenum alloy (SiMo) hot shoe are doped to provide thermoelectric polarity: phosphorous is the dopant for the N-leg and boron is the dopant for the P-leg. The N and P legs are equal in size, 2.74 mm x 6.50 mm in cross section, with a total length of 20.3 mm. Couple height is 31.1 mm and the hot shoe measures 22.9 mm x 22.9 mm and is 1.9 mm thick. The SiGe alloy thermocouple is bonded to a cold stack assembly of tungsten, copper, molybdenum, stainless steel, and alumina parts which separate the electrical and thermal currents. Copper connectors form the electrical circuit in the space between the inside of the outer shell (“converter housing”) and the outside of the insulation system. The electrical circuit uses a two-string, series-parallel wiring design for reliability (power is still provided in the event of a single unicouple open circuit or short-circuit failure). The circuit loops are arranged to minimize the net magnetic field of the generator. Each unicouple is electrically insulated from the multifoil insulation by several layers of Astroquartz (SiO₂) yarn (nominal diameter 0.76 mm) wound tightly around the couple legs and by an alumina wafer beneath the hot shoe.^{7,11,14,15,16}

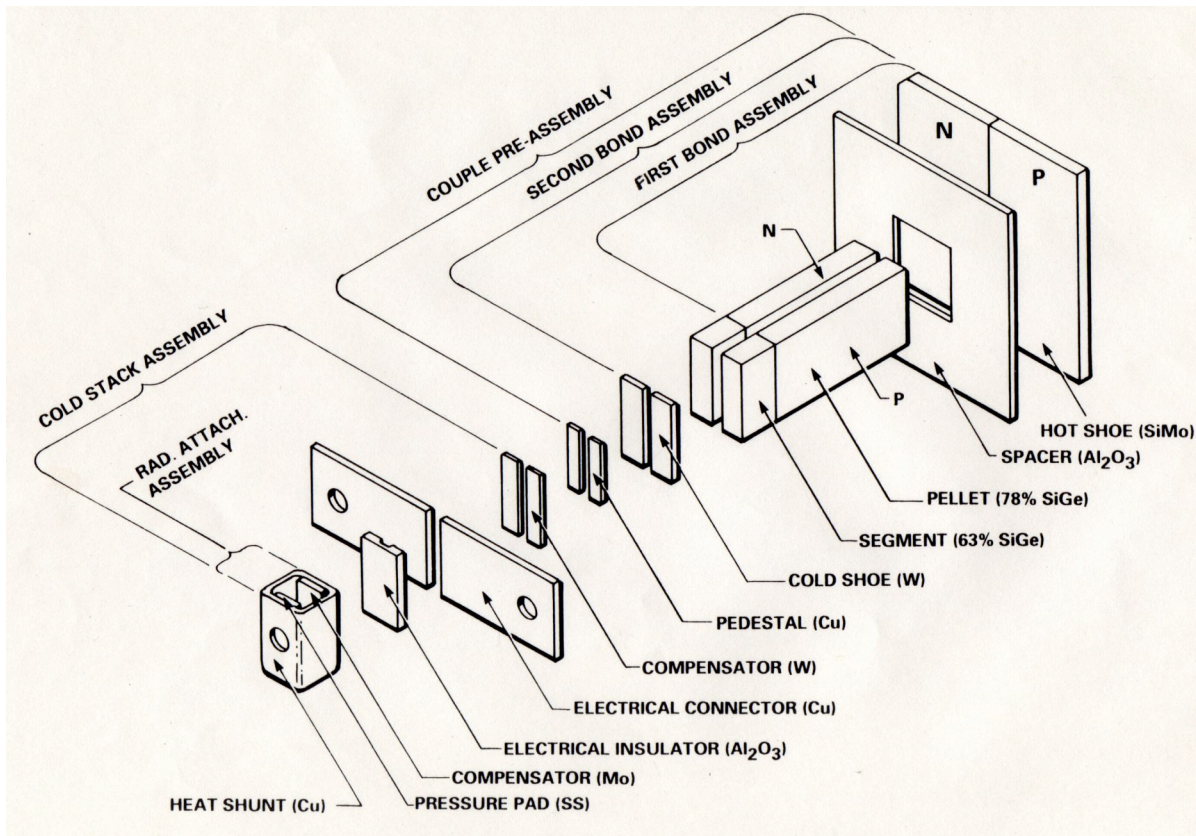

Figure 6. Exploded view of a silicon-germanium alloy thermoelectric element (“unicouple”) as used in the GPHS-RTGs and the MHW-RTGs. Details, including dimensions, are given in the text. (Lockheed Martin)

The hot junction temperature averages about 1273 K at BOM and the cold junction temperature averages about 566 K. The corresponding nominal hot shoe temperature is about 1308 K.^{7,17}

The multifoil insulation assembly, which serves as a thermal barrier, consists of 60 layers of molybdenum foil and 60 layers of Astroquartz cloth. The support frame for the insulation system is made of molybdenum. The outer shell assembly, which is made of a type 2219-T6 aluminum alloy forging, consists of a flanged cylinder with eight radial fins and four midspan bosses. Other components such as the electrical power connector, four resistance temperature devices (RTDs), gas management system (GMS), and pressure relief device (PRD) are mounted to the outer shell and sealed by the use of C-seals. The inboard flange has four barrel nuts mounted on the four main load carrying ribs to mount the GPHS-RTG to the spacecraft. A silicone coating applied to the outer shell raises its emissivity to about 0.9. To limit the heat radiated from the converter surface to the launch vehicle, an active cooling system (ACS) consisting of tubular passages near the base of each fin permits water circulation to remove approximately 3,500 Wt. (The ACS was not activated on Cassini or New Horizons.)^{6,16}

There are two principal modes of operation for the GPHS-RTG: air and vacuum. During air (ground) operation, the RTG is filled with an inert gas (normally argon for testing and storage and xenon at launch) to protect the molybdenum and graphitic components from oxidation. Full power operation in space is achieved after venting the inert gas through the PRD.

Unless otherwise specified, the GPHS-RTG program defined the RTG power output to be the power at the RTG power connector pins. Both in the test program and in the actual mission, corrections were applied to the measured powers (which were not at the pins) to obtain the powers at the pins.

2.2 General-Purpose Heat Source (GPHS)

The thermal power provided to the converter comes from the general-purpose heat source (GPHS) assembly, which consists of a stacked column of 18 individual modules each providing about 245 Wt from the natural decay of encapsulated plutonium-238 (Pu-238) oxide fuel, which has a half-life of 87.7 years. Nominally, the plutonium is enriched to about 83.5% Pu-238, although this has varied with later generators. As a result of the Pu-238 half-life, the reduction of thermal power is only approximately 0.8 percent per year which makes it ideal for long-duration missions. (Various changes in the properties of the uncouple materials can add to the electrical power decay with time.)^{6,16}

A cutaway view of a single GPHS module is shown in Figure 7. Safety was the principal design driver for the GPHS. The main safety objective was to keep the fuel contained or immobilized to prevent inhalation or ingestion by humans. The modules are composed of five main elements: the fuel; the fuel cladding; the graphite impact shell (GIS); the carbon-bonded carbon fiber (CBCF) insulation; and the Fine Weave Pierced Fabric (FWPFTM) aeroshell. Each module contains four fuel pellets made of a high-temperature ceramic with a thermal inventory of approximately 62.5 Wt per pellet. Each module has a total mass of about 1.43 kg (except for F-8, see below). Nominally (and allowing for tolerances on the fuel loading of the individual pellets), the total thermal power for the GPHS assembly is about 4410 Wt at beginning of life (BOL) which translates into about 8.1 kg of Pu-238 per generator. (Because of the plutonium-238 decay, the actual thermal inventories vary depending on when the fuel was made; thus, different thermal inventories will be reported for different missions. For example, for New Horizons, because of the over 21-year-old fuel in 52 of the 72 fueled clads, the estimated thermal power at launch was only 3948 Wt.)¹⁸⁻²²

The GPHS went through a number of exacting engineering tests to assess its performance under operating conditions, including vibration and operating temperature.²⁰ An extensive safety testing and analyses program has been conducted to assess the GPHS performance under a range of postulated accident conditions such as launch pad explosions, projectile impacts, propellant fires, impacts, and atmospheric reentry.^{21,22} Separate, detailed safety analysis reports, independent safety evaluation reports, and environmental impact statements have been completed for each of the missions (Galileo, Ulysses, Cassini and New Horizons).^{21,22,23,24} The public and independent agencies such as the Environmental Protection Agency (EPA) and the U.S. Nuclear Regulatory Commission (NRC) have been involved in these four separate reviews. Based upon independent assessments of this detailed work have come individual presidential launch approval decisions for each of the four missions.

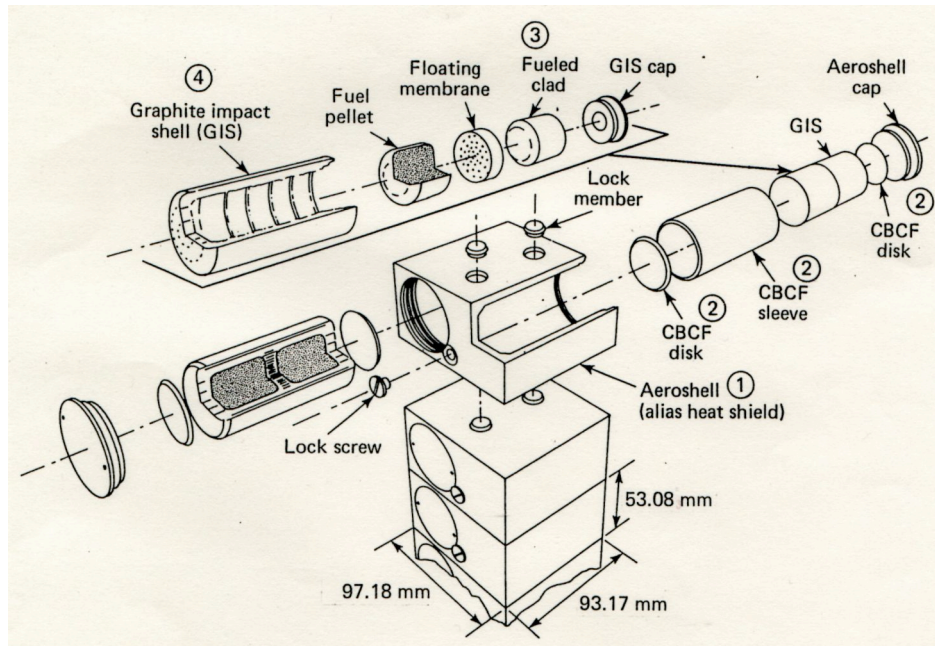

Figure 7. Cutaway of a general-purpose heat source (GPHS) module. (DOE/LMA/APL)

The fuel pellets have a diameter of about 2.76 cm and a length of about 2.76 cm. Each fuel pellet within a GPHS module is individually encapsulated in a welded iridium alloy (DOP-26) clad that has a minimum wall thickness of 0.55 mm. The DOP-26 alloy is capable of resisting oxidation in a hypothetical post-impact environment while also being chemically compatible with the fuel and graphitic components during high-temperature operation and postulated accident environments. The combination of fuel pellet and iridium cladding is referred to as a “fueled clad”.^{21,22}

Two fueled clads are encased in a graphite impact shell (GIS) made of FWPFTM, a carbon-carbon composite material. The cylindrical GIS is designed to provide protection to the fueled clads for postulated impact accidents. In turn, two graphite impact shell assemblies, each containing two fueled clads, are located in each FWPFTM aeroshell. A carbon-bonded carbon fiber (CBCF) insulator surrounds each GIS within the aeroshell to limit the peak temperature of the fueled clad during inadvertent reentry and to maintain a sufficiently high temperature to ensure its ductility upon the subsequently postulated impact. The aeroshell serves as the primary structural member of the GPHS module as it is stacked inside the GPHS-RTG. The aeroshell is designed to contain the two graphite impact shell assemblies under a wide range of postulated reentry conditions and to provide additional protection against postulated impacts on hard surfaces at terminal velocity. FWPFTM was selected because its composite structure gave it a high margin of safety against the thermal stresses associated with postulated atmospheric reentries.^{18,19,20,25} The aeroshell also provides protection for the fueled clads from postulated launch vehicle explosion overpressures and fragment impacts and it can provide protection in the event of a propellant fire. For the New Horizons GPHS-RTG, a modification of the aeroshell was made to include a web around the graphite impact shells. This has been termed the “Step 1” modification to the basic GPHS design and, while it was done to enhance safety, it also increased the mass of the module to about 1.51 kg. References 18 to 22 provide more information on the design, development and qualification of the GPHS.

3. Performance Tests

Mission, spacecraft and launch vehicle requirements and environments established the top-level specification for the GPHS-RTG. These launch vehicle environments affected both the GPHS and the GPHS-RTG. Originally designed for the International Solar Polar Mission (which became the Ulysses mission), the GPHS-RTG had to

accommodate the Galileo, Cassini, and New Horizons missions. The principal requirements were levied on power (at launch, BOM, EOM); structural (ability to withstand launch vibrations and pyrotechnic shock); magnetic field strength; mass properties (mass, center of mass, moments of inertia, products of inertia); pressurization; nuclear radiation; and general functional attributes (insulation resistance, internal resistance, pressure decay, nonsusceptibility to electrostatic discharging).^{6,7,8,11,16} The results for the tests for the Galileo, Ulysses and Cassini missions will be presented here. The results from the New Horizons tests will be reported in separate papers at this Conference.^{5,13,26}

3.1 Test Philosophy

The test philosophy for the GPHS-RTG program required that hardware be built and tested through increasing levels of assembly. Initially, thermoelectric elements (unicouples) were built and tested to verify that the MHW-RTG uncouple properties had been duplicated. Then modules of 18 uncouples were assembled and tested to provide an early indication of the performance of interconnected uncouples and associated hardware (e.g., insulation). For the Galileo/Ulysses RTG program, full-scale Component Engineering Test (CET) units were built and tested for structural and mass properties. The successful completion of such system-level tests removed the need to perform them for future missions where no significant changes were made in the design and fabrication.^{6,11,14,15,16}

To verify the design, a non-nuclear electrically heated Engineering Unit (EU) was assembled and tested. For Ulysses and Galileo, this early test of the design proved to be very important in that a vibration test uncovered a problem that necessitated adding four clamps to hold the foil insulation basket. Overall qualification of the design and assembly and testing operations was accomplished with the nuclear-heated Qualification Unit (QU).¹¹

The first four GPHS-RTG flight units (F-1, F-3, F-4, and F-5) were assembled and tested in 1985 at Mound for the Galileo and Ulysses missions. (Converter E-2 was not fueled for Galileo and Ulysses because it had been accidentally exposed to air during an electrically heated ground test in October 1983. Since the effect of air exposure was a drop of only a few watts, E-2 was later accepted for use on the Cassini spacecraft.) Flight units F-2, F-6 and F-7 were assembled and tested at Mound in 1996 for the Cassini mission. Flight unit F-5, which had been assembled at Mound, became the spare for the Galileo, Ulysses and Cassini missions. It was later defueled at INL so the fueled clads could be used in F-8 for New Horizons. Flight Unit F-8 was assembled and tested at the Idaho National Laboratory in 2005 for the New Horizons mission. The general sequence of tests performed on the flight RTGs is summarized in Table 1 beginning with converter assembly and testing at General Electric (GE) (later Lockheed Martin (LM)) then moving to DOE laboratories for the RTG assembly and testing work: Mound (Galileo, Ulysses, and Cassini) or the Idaho National Laboratory (INL) for New Horizons.^{5,6,11,13,16}

Table 1. Performance sequence for GPHS-RTG assembly and testing.

- | | |
|---|---|
| <ul style="list-style-type: none"> • Converter fabrication and testing | <ul style="list-style-type: none"> • LM fabricated and processed the converter. Electrically heated thermoelectric generator (ETG) performance testing was done to measure power and other properties in vacuum and with an argon cover gas. |
| <ul style="list-style-type: none"> • RTG fueling and processing | <ul style="list-style-type: none"> • Mound (later INL) inserted the GPHS modules into the converter and measured the electrical performance both in a vacuum and with an argon cover gas. |
| <ul style="list-style-type: none"> • Vibration testing | <ul style="list-style-type: none"> • Mound (later INL) conducted these tests with the goal of determining the functional integrity (including resistance to leaks) |
| <ul style="list-style-type: none"> • Magnetic field measurements | <ul style="list-style-type: none"> • Mound measured the magnetic field |
| <ul style="list-style-type: none"> • Mass properties measurements | <ul style="list-style-type: none"> • Mound (later INL) measured and/or calculated the |

masses, centers of mass, moments of inertia, products of inertia, etc. of the RTGs

- Nuclear radiation measurements
- Thermal vacuum tests
- Mound (later INL) measured the neutron and gamma radiation dose rates of the RTGs
- Mound (later INL) measured the RTG powers under simulated space (vacuum) conditions

3.2 Converter Performance

After appropriate processing each converter was tested in a vacuum environment using an electrically heated electric heat source (EHS) to provide the thermal input simulation of a GPHS assembly. Table 2 shows the performance of each of the flight converters assembled in the Galileo/Ulysses/Cassini production program. The beginning-of-life (BOL) power, which is presented as the power at the connector pins, was normalized to a thermal input of 4402 Wt by using a computed adjustment of 0.12 We/Wt. The “circuit isolation” resistance is a measure of the integrity of the electrical isolation or insulation system since it represents the insulation resistance between the thermoelectric circuit and the outer case. The requirement was to have an isolation resistance greater than 1,000 ohms (Ω). In some earlier papers and reports this has been referred to as the “shunt resistance”.^{6,16}

Table 2. Electrically Heated Thermoelectric Generator (ETG) Performance^{6,16}

<u>Parameter</u>	<u>Requirement</u>	<u>E-1</u>	<u>E-2</u>	<u>E-3</u>	<u>E-4</u>	<u>E-5</u>	<u>E-6</u>	<u>E-7</u>
Date (DD/MM/YY)		1/8/83	1/10/83	12/2/84	23/4/84	30/6/84	15/2/95	19/2/96
BOL Power (We)	≥ 293	295.6	294.8	298.1	296.0	297.5	293.4	294.6
Load Voltage (V)	30	30	30	30	30	30	30	30
Circuit Isolation (Ω)	>1000	2100	1900	2200	3100	4600	2600	1200

For a thermal input of 4402 Wt, E-8, which was assembled for New Horizons, produced 295.4 We in a thermal vacuum test. This indicates the power output the F-8 converter was capable of providing had there been fresh fuel for New Horizons.¹³

As noted earlier, in October 1983, during preparations for the argon performance testing of E-2, the converter was accidentally exposed to air for a brief period because of an imploded glove port. The oxidation of some of the molybdenum foil surfaces led to an increase in their emissivities which in turn caused an electrical power loss of about 2.6 We from the value shown in Table 2. While E-2 was not fueled for the Galileo and Ulysses missions, it was fueled and used for the Cassini mission.¹⁶

3.3 RTG Assembly

The RTGs (Qualification Unit and flight units) were assembled in the Inert Atmosphere Assembly Chamber (IAAC) at Mound (except for F-8 which was assembled at INL). Mound and INL performed initial RTG functional performance measurements before the end domes were attached and before the RTGs were removed from the IAAC. These performance measurements included power output, load voltage, open circuit voltage, current, internal resistance, isolation (“insulation”) resistance, average outer case temperature (requirement ≤ 533 K) as measured by resistance temperature devices (RTDs) and bell jar temperature. These measurements were performed in an argon

atmosphere and again in vacuum to provide initial data on the expected RTG performance on-pad and at BOM. Pressure decay measurements were also made.^{6,16}

3.4 Vibration Performance

Vibration tests were performed on CET-1, the Engineering Unit (EU), the Qualification Unit, and each of the flight RTGs. As noted earlier, the initial vibration test of the Engineering Unit led to a minor redesign: the replacement of four unicouples (leaving a total of 572 unicouples) by inner insulation frame supports. The power requirements were still met.^{11,16}

The Engineering Unit and the Qualification Unit were subjected to flight acceptance (FA) and type acceptance (TA) vibrations. During the TA vibrations the dynamic environments were 50% more severe in amplitude and longer in duration than the expected launch environment. Successful completion of the TA vibration tests would demonstrate that the GPHS-RTG design had more than sufficient structural strength margin. While all of the RTGs were vibration tested, some additional analyses and/or component testing were required for the different (warmer) environments of the Titan IV/Centaur (Cassini) and the Atlas V 551 (New Horizons).^{5,6,11,13,16,26}

The criteria for satisfactorily demonstrating the ability of an RTG to withstand these environments was the observation of no visual damage and meeting the post-vibration functional test requirements (power, isolation resistance, internal resistance and pressure decay).

A common set of dynamic test environments with appropriate notching was developed to encompass the different mounting configurations used on the different spacecraft. In addition to random vibration and transient vibration tests, the Engineering Unit was subjected to acoustic testing and pyrotechnic shock testing. The Engineering Unit successfully passed these tests thereby verifying the GPHS-RTG design concept for these environments.¹⁶ Table 3 summarizes the dynamic acceptance test sequence. With the exception of the transient vibration environment, these are conventional environments normally encountered in the qualification testing of spacecraft equipment. (The New Horizons vibration tests will be separately reported at this conference.^{5,13,26})

Table 3. Vibration Test Sequence Summary^{6,16}

<u>Test Number</u>	<u>Axis</u>	<u>Environment</u>	<u>Duration</u>
1	Y	½ g sine sweep	10-2000 Hz, 2 octaves/min
2	Y	FA random	1 minute at 0 dB
3	Y	FA transients	1 pulse at 0 dB, 4 frequencies
4	Y	½ g sine sweep	10-2000 Hz, 2 octaves/min
5	Z	½ g sine sweep	10-2000 Hz, 2 octaves/min
6	Z	FA random	1 minute at 0 dB
7	Z	FA transients	1 pulse at 0 dB, 4 frequencies
8	Z	½ g sine sweep	10-2000 Hz, 2 octaves/min

NOTE: The random and transient environments were defined in Lockheed Martin Specification 23009150 for the Cassini mission and in Specification NS0020-05-04 for the Galileo and Ulysses missions. The spectra can be viewed in References 8 and 11.

All of the RTGs met their vibration, shock and load requirements.

3.5 Magnetic Performance

The test criteria for the total dipolar magnetic field vector for the Galileo and Ulysses flight RTGs were 30 nT at 1 meter and 1 nT at 2 meters. Measurements made on F-1 (after final deperm and correction to BOM current) yielded a maximum value of 148 nT at 1 m with an estimated value of 10 nT at 2 meters. It was determined that this deviation occurred because of an uncompensated current loop in the converter. The test criteria were waived for Galileo since the measured field was not a constraint on the mission. For the Ulysses RTG (F-3), compensation magnets were installed.^{11,16}

For Cassini, the requirement was that the total dipolar magnetic field vector should not exceed 78 nT at 1 m from the geometric center of the RTG, with or without compensating magnets. Both F-6 and F-7 exceeded this requirement leading to studies of components in the RTGs. After the Jet Propulsion Laboratory (JPL) and the European Space Agency analyzed the data and separated the permanent magnetic field from the current-induced field, the field strength was estimated to be 80 nT at 1 m for F-6 (with an uncertainty of ± 4 nT) and 74 nT for F-7. On the basis of these calculations, both RTGs were accepted by JPL.⁶

3.6 Mass Properties

The requirement on each flight RTG was that the mass be less than or equal to 56.2 kg (56.7 kg was used on Cassini and 58.0 kg was used for New Horizons).^{6,16} The mass was determined by measuring the RTG gross weight and subtracting the weights of any non-flight items installed on the RTG. Centers of mass, moments of inertia, and products of inertia were also determined. Table 4 summarizes the masses for the Galileo, Ulysses, Cassini and New Horizons RTGs. The mass of the Ulysses RTG (F-3) includes the effects of the compensation magnets. The masses of the Cassini RTGs were larger than those of the Galileo and Ulysses RTGs in part because of a changed PRD (including adapter plate). The increased mass of the New Horizons RTG includes those changes plus the heavier GPHS modules that resulted from the Step 1 design change (see Section 2.2).

Table 4. Flight Unit Mass Comparison^{6,16}

<u>Unit</u>	<u>Flight Mass (kilograms)</u>
F-1 (Galileo)	55.95
F-2 (Cassini)	56.31
F-3 (Ulysses)	55.81
F-4 (Galileo)	55.92
F-5 (spare)	55.94
F-6 (Cassini)	56.45
F-7 (Cassini)	56.51
F-8 (New Horizons)	57.91

3.7 Nuclear Radiation

The specification neutron emission rate from the unshielded GPHS assembly was not to exceed 7.0×10^3 neutrons per second per gram of plutonium-238, exclusive of any neutron multiplication obtained from the configuration of the fueled clads in the assembled heat source or attenuation within the RTG. An oxygen-16 exchange process was employed during the production of the fuel pellets to minimize the neutron emission rate. The measurements for the Qualification Unit showed a neutron emission rate of 5.9×10^3 neutrons per second per gram of plutonium-238. Neutron and gamma radiation dose measurements are reported in References 8 and 11. At one meter, depending on the angle with respect to the RTG, the neutron dose rate varied from about 20 mrem/h to

about 50 mrem/ while the gamma dose rate (in neutron dose equivalent) varied from about 5 mrem/h to about 10 mrem/h.

3.8 Thermal Vacuum Tests

The thermal vacuum testing provided the basis for the power projections, both beginning-of-mission (BOM) and end-of-mission (EOM), for each RTG. Vacuum testing to simulate space conditions ranged from 6 hours to over 40 hours in the thermal vacuum chamber at a pressure of 0.1 mPa or less and an average sink temperature of about 309 K. Figure 8 shows the current-voltage-power (I-V-P) characteristics of the Qualification Unit.^{8,11,27} Note that the 28-V and 30-V operating levels are near the peak power points. Table 5 shows the thermal vacuum performance for each of the first seven flight RTGs.^{6,16,28-31} For F-8, the measured power output during thermal vacuum testing was 247 We.¹³ For E-2 and F-5, which had been built during the Galileo/Ulysses program, the more recent Cassini measurements are listed.⁶ F-5 shows the effects of over 10 years of decay in 1995. The originally planned Galileo/Ulysses spare (F-4) was tested twice, once under Galileo load conditions (30 V) and once under Ulysses load conditions (28 V). Measured currents ranged from a low of 8.45 A for F-5 to a high of almost 10 A (e.g., F-7). The thermal inventory (heat input) of the GPHS is shown for the indicated date of completion of the thermal vacuum test. Three power outputs are shown: the actual measured power; the power corrected for losses in the connector resistance; and the power normalized to 4410 Wt (using 0.12 We/Wt). (Technical reports often include and Table 5 lists a fourth power value which accounts for the fact that the RTGs were vented through the gas management valve (GMV) which is more restrictive than the flight PRD. This “GMV vent effect” is estimated to have an approximately 1.8-We to 3.0-We effect so the normalized powers at the pins should be increased by ~3 We.)^{6,16}

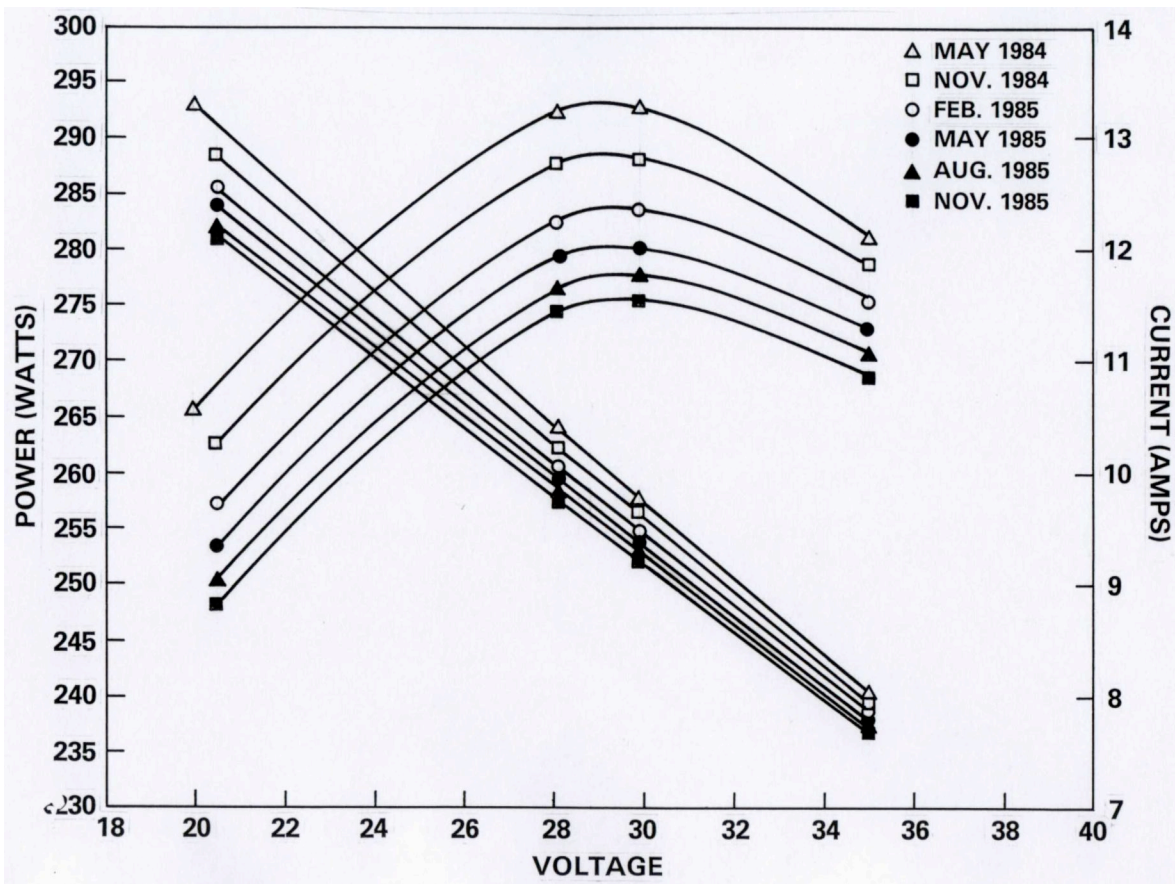

Figure 8. GPHS-RTG Qualification Unit current-voltage-power (I-V-P) map at different times in the life test.

Because of the Challenger accident, the originally planned 1986 launches of Galileo and Ulysses were moved to 1989 for Galileo and 1990 for Ulysses. Appropriate changes (discussed in Sections 2 and 4) were made in the power requirements to reflect the three- to four-year power decay for the Galileo and Ulysses RTGs. The power requirements for Cassini and New Horizons were similarly adjusted to reflect their RTG fuel loadings and spacecraft launch dates. All eight flight RTGs met the performance requirements.

Table 5. Flight Unit Thermal Vacuum Performance^{6,16,28,29,30,31}

<u>Parameter</u>	<u>F-1</u>	<u>F-2</u>	<u>F-3</u>	<u>F-4</u>	<u>F-4</u>	<u>F-5</u>	<u>F-6</u>	<u>F-7</u>
Date (DD/MM/YY)	14/12/84	6/3/96	15/8/85	20/7/85	21/7/85	5/10/95	8/2/97	21/11/96
Heat Input (Wt)	4460.1	4416.5	4479.1	4435.2	4435.1	4091.1	4429.7	4427.7
Power Output (We)								
As measured	306.1	297.2	303.1*	301.4	302.8	254.6	295.2	296.6
Corrected to pins [†]	308.2	299.2	305.4*	303.7	304.8	256.0 [‡]	297.2	300.6
Normalized to 4410 Wt input [§]	302.0	298.4	297.1*	300.7	301.8	257.1	294.8	298.5
With GVM vent correction (+3We)	305.0	301.4	300.1	303.7	304.8	260.1	297.8	301.5
Requirement	>292	291	>292	>292	>292	255	293	293
Load Voltage (V) (Galileo: 30 V; Ulysses: 28 V)	30.02	30.02	28.02	28.04	29.97	30.03	29.95	29.98
Open Circuit Voltage (V)	52.42	52.09	51.75	51.37	51.94	50.28	51.88	52.34
Internal Resistance (Ω)	2.197	2.229	2.194	2.169	2.174	2.387	2.225	2.245
Insulation Resistance (kΩ) (thermopile to case) (Requirement: >1.0 kΩ)	2.2	3.73	2.1	3.4	3.4	29.31	6.5	3.44
Average RTG case temperature (K) (Requirement <533 K)	520	517.1	520	519	519	509.6	518.4	519.1

*Power not stabilized

[†]Corrected = Measured Power + (0.02) I² where I = measured RTG output current; (0.02) = pin contact resistance (ohm, Ω)

[§]Normalized using 0.12 electrical watt (We) per thermal watt (Wt) input; F-5 normalized to 4100 Wt

[‡]Power still increasing at end of test; 258 We estimated final power

4. Power Projections

The test results given in Table 5 were used to make the power projections. To determine the beginning-of-mission (BOM) power, the corrected test data in Table 5 were adjusted to account for the accuracy of the measurements (on the order of ± 0.6 We); effects of fuel decay during storage (about 0.8% per year); the power loss resulting from the precipitation of the uncouple dopants during storage (several watts); and the effect of using the more restrictive gas management valve (GMV) during testing (usually taken to be ~ 3 We).^{6,16}

The projected launch power, which is that power produced when the RTG is filled with xenon, was calculated by multiplying the BOM power by a factor of 0.764 determined from tests with the Qualification Unit.^{6,16}

The end-of-mission (EOM) power was calculated using a computer model that included the effects of radioisotope fuel decay; precipitation of the boron and phosphorus dopants used in the uncouples; changes in the thermal conductivity of the uncouple alloys; sublimation of the uncouple materials; sink temperatures; and the effects of carbon monoxide. This model has been checked against the extensive database on uncouples, including the four MHW-RTGs used on Lincoln Experimental Satellites 8 and 9 (LES 8/9) and the six MHW-RTGs used on the two Voyager spacecraft. (The MHW-RTGs used the same uncouple design as used on the GPHS-RTGs and both RTGs have a similar molybdenum foil/Astroquartz insulation system.)³²⁻⁴²

4.1 Galileo Power Performance

After a 3.5-year delay caused by the Challenger accident, the Galileo spacecraft (2380-kg Orbiter and 335-kg Probe) was launched on 18 October 1989 on Space Shuttle Atlantis (STS 34). Arriving at Jupiter in December 1995 after a circuitous route past Earth and Venus, the Galileo Orbiter investigated the Jovian atmosphere; the Galilean satellites (Io, Europa, Ganymede, and Callisto); and the Jovian environment (magnetosphere, energetic particles, plasmas, and fields). The Galileo Probe, which was battery-powered (since it was a short-lived mission), was kept warm with a number of 1-Wt light-weight radioisotope heater units (LWRHUs). The Probe entered the atmosphere of Jupiter on 7 December 1995 where it directly measured a number of properties of the Jovian atmosphere.

As a result of the Challenger accident, the upper stage for Galileo was changed from the liquid-fueled Centaur to the less powerful solid-fueled Inertial Upper Stage (IUS). This necessitated using gravity assists at Venus (10 February 1990) and Earth (8 December 1990 and 8 December 1992) to send the Galileo Orbiter and Probe to Jupiter. On the way to Jupiter, Galileo flew past two asteroids (Gaspera on 29 October 1991 and Ida on 28 August 1993) to provide the first close-up looks at these small bodies. On 7 December 1995, the Galileo Orbiter was inserted into orbit around Jupiter and the Galileo Probe entered the atmosphere of Jupiter providing the first-ever in situ information on the Jovian atmosphere. The primary mission lasted until December 1997.

Figure 9 shows the power output of the two Galileo GPHS-RTGs as of July 1997.^{6,43-47} Both GPHS-RTGs met their power requirements which enabled NASA and JPL to extend the mission three times until 2003. Because the spacecraft was running out of onboard propellant, the Galileo Orbiter was deliberately inserted into the atmosphere of Jupiter on 21 September 2003 to prevent any possible impact on Europa (which scientists believed contained an ocean which, in turn, could mean life). Galileo had successfully completed 35 orbits of Jupiter providing a wealth of data on the Jovian system and its four largest satellites (Io, Europa, Ganymede, and Callisto). The end was a dramatic climax to a 14-year mission that included investigations of Earth, Venus, two asteroids (Gaspera and Ida and its moon Dactyl), views of comet Shoemaker-Levy 9 crashing into Jupiter and the successful insertion of the Galileo Probe into the Jovian atmosphere.

The post-Challenger mission requirements called for a BOM power of 568 We combined total from the two GPHS-RTGs (F-1 and F-4) and an EOM power of 470 We after 71,000 h (8.1 years). Based on the telemetry data, the BOM power was 577.2 We (with an accuracy of ± 3.5 We). (Power was calculated from the bus voltage and the output current of each RTG.) The predicted BOM power was in the range of 571 We to 576 We. The power at EOM was 482 We which exceeded the specification requirement of 470 We by 12 We. The range of predicted EOM powers was from 475 We to 489 We. (The plateaus in the power profile in Figure 9 are the result of the inner Solar System maneuvers.)^{6,11,16}

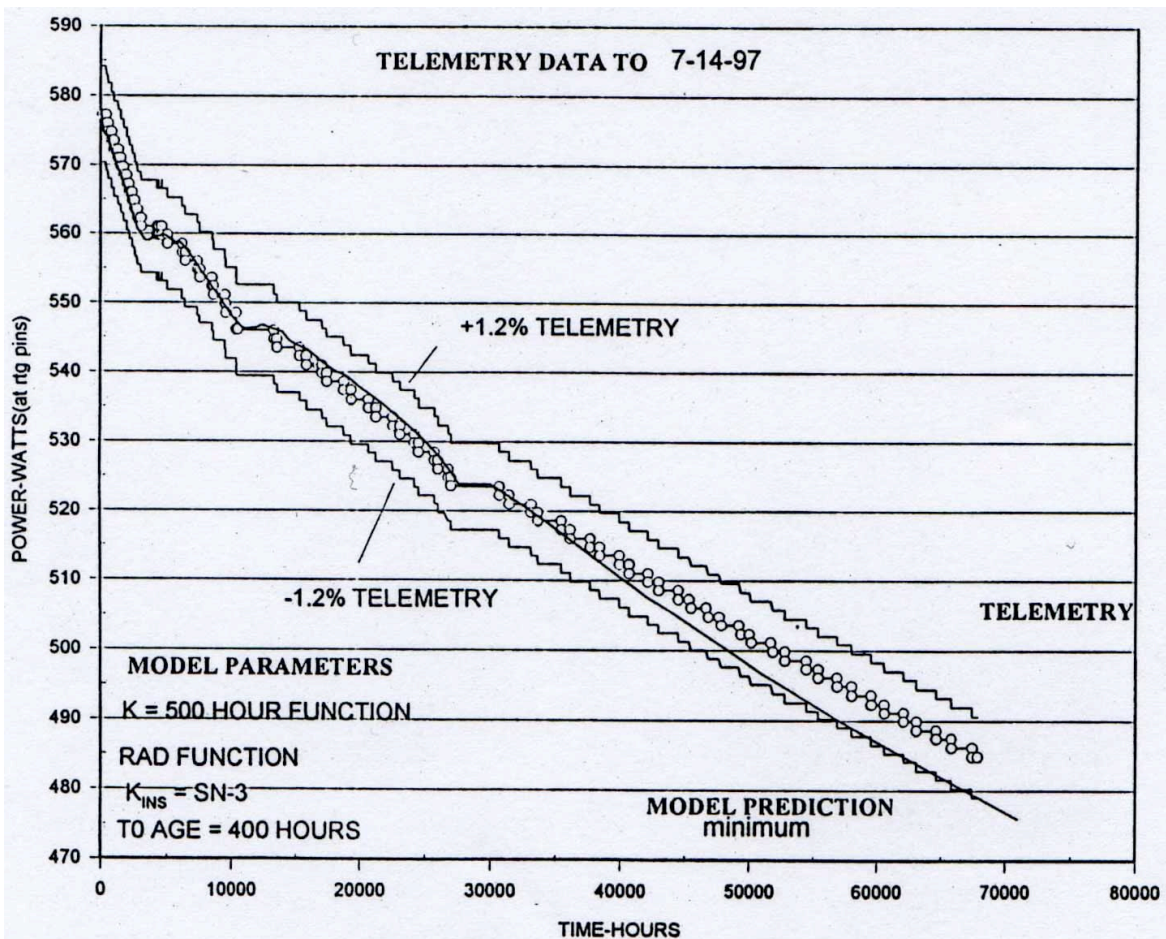

Figure 9. Total Galileo GPHS-RTG Power Output (summation of F-1 and F-4) to 14 July 1997.

4.2 Ulysses Power Performance

After a 4.5-year delay caused by the Challenger accident, the 371-kg Ulysses spacecraft was launched on 6 October 1990 on Space Shuttle Discovery (STS 41). The primary objectives of Ulysses “are to investigate, as a function of solar latitude, the properties of the solar wind and the interplanetary magnetic field, of galactic cosmic rays and neutral interstellar gas, and to study energetic particle composition and acceleration” <<http://nssdc.gsfc.nasa.gov/>>.

The Ulysses mission had from the beginning included a Jupiter gravity assist (8 February 1992) in order to rotate the plane of the trajectory out of the plane of the ecliptic. In this way Ulysses could fly over the polar regions of the Sun. (The flight to Jupiter necessitated the use of nuclear power.)

Figure 10 shows the power output of the Ulysses GPHS-RTG (F-3) as of April 1997.^{6,43-47} The GPHS-RTG met its power requirements which enabled the European Space Agency (ESA) to extend the mission several times (current EOM is listed as March 2008 when Ulysses completes its third north polar pass). Ulysses has enabled scientists for the first time to study as a function of heliographic latitude the properties of the solar wind; the

structure of the Sun/wind interface; the heliospheric magnetic field, solar radio bursts and plasma waves; solar x-rays; solar and galactic cosmic rays; and both interstellar and interplanetary neutral gas and dust.

The post-Challenger mission requirements called for a BOM power of 277 We and an EOM power (42,000 h or 4.8 years) of 245 We at the RTG connector. Unlike Galileo, there is no direct measurement of the power; instead an algorithm is used. The algorithm considers (1) the main bus current; (2) an internal power dump current; and (3) nominal power consumption values for ten spacecraft components if they are operating at the time. The Ulysses spacecraft operates at a nominal load voltage of 28 V (Galileo operated at 30 V).^{6,11}

The initial telemetry power was reported to be 284 We at the bus and 289 We at the RTG connector, both of which exceeded the 277-We minimum BOM requirement. Pre-launch predictions were in the range of 282 We to 287 We at the connector. The August 1995 "EOM" power was reported to be 248 We which exceeded the 245-We requirement.⁶

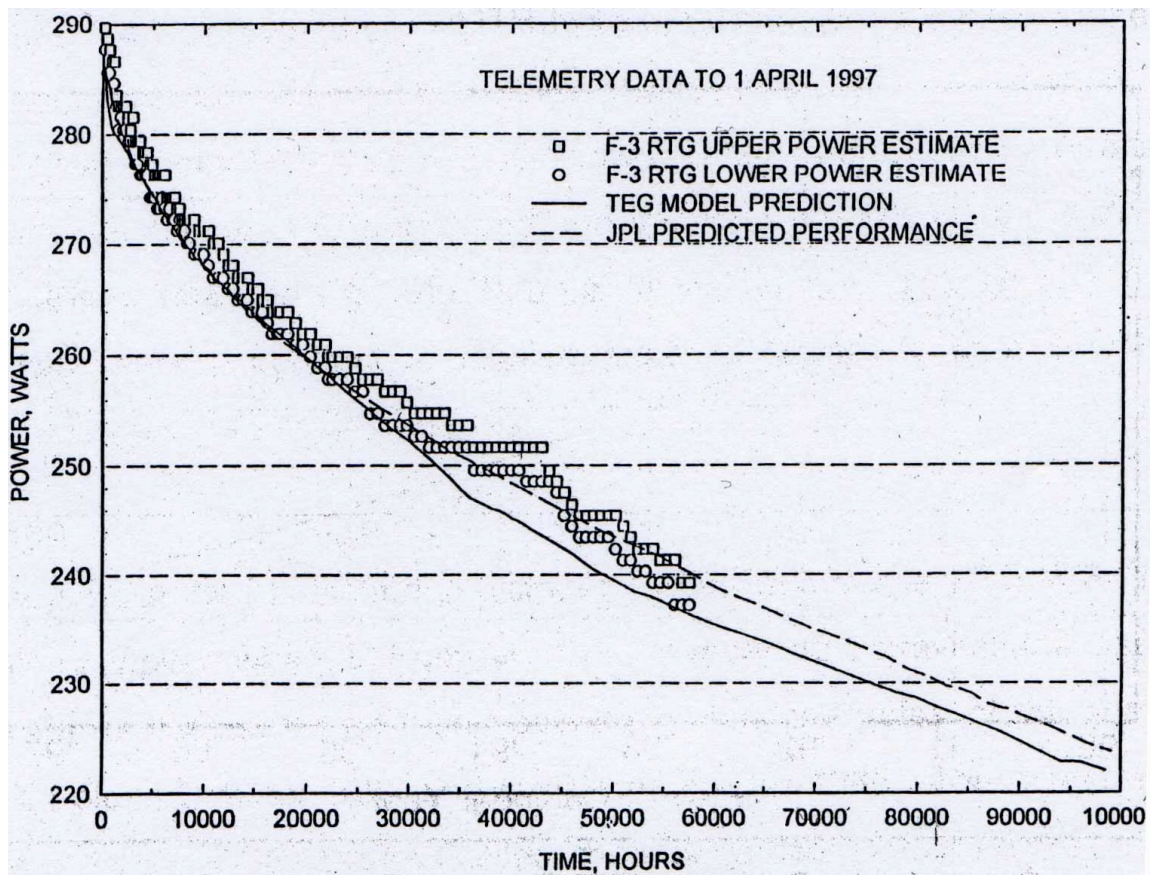

Figure 10. Ulysses GPHS-RTG (F-3) Power Output to 1 April 1997.

4.3 Cassini Power Performance

The 5574-kg Cassini spacecraft with the ESA-built Huygens Titan Probe was launched on 15 October 1997 on a 6.7-year voyage to Saturn. The principal objectives include detailed studies of the planet and its rings and satellites. A major focus is on studying Titan, Saturn's largest moon.

Whereas Galileo and Ulysses were launched in Space Shuttles, Cassini was launched on an expendable Titan IV/Centaur launch vehicle. To achieve the necessary energy to get to Saturn, Cassini used gravity assists from

Venus (26 April 1998 and 24 June 1999), Earth (18 August 1999) and Jupiter (30 December 2000). While in the vicinity of Jupiter, Cassini was able to work in conjunction with the Galileo Orbiter to conduct a “Jupiter Millennium Flyby” (October 2000 to February 2001). Cassini achieved Saturn orbit insertion on 1 July 2004 and is halfway into its four-year main mission. (Huygens, with its LWRHUs, successfully landed on Titan on 14 January 2005 providing the first in situ data on the surface of this cloud-covered satellite.) During the main mission Cassini will make 74 orbits of Saturn with 44 flybys of Titan. Given the successful performance of previous GPHS-RTGs, Cassini should have enough power for an extended mission.

Figure 11 shows the power output of the three Cassini GPHS-RTGs (F-2, F-6, and F-7) from 15 October 1997 to 30 June 2004. Based on telemetry data and correcting for cable losses, the measured BOM power of the combined RTGs was 887 We which exceeded the specification requirement of 826 We. The projected power at 16 years after BOM is 640 We which will exceed the specification requirement of 596 We.^{6,48,49} All in all the Cassini RTGs should provide ample power for an extended mission.

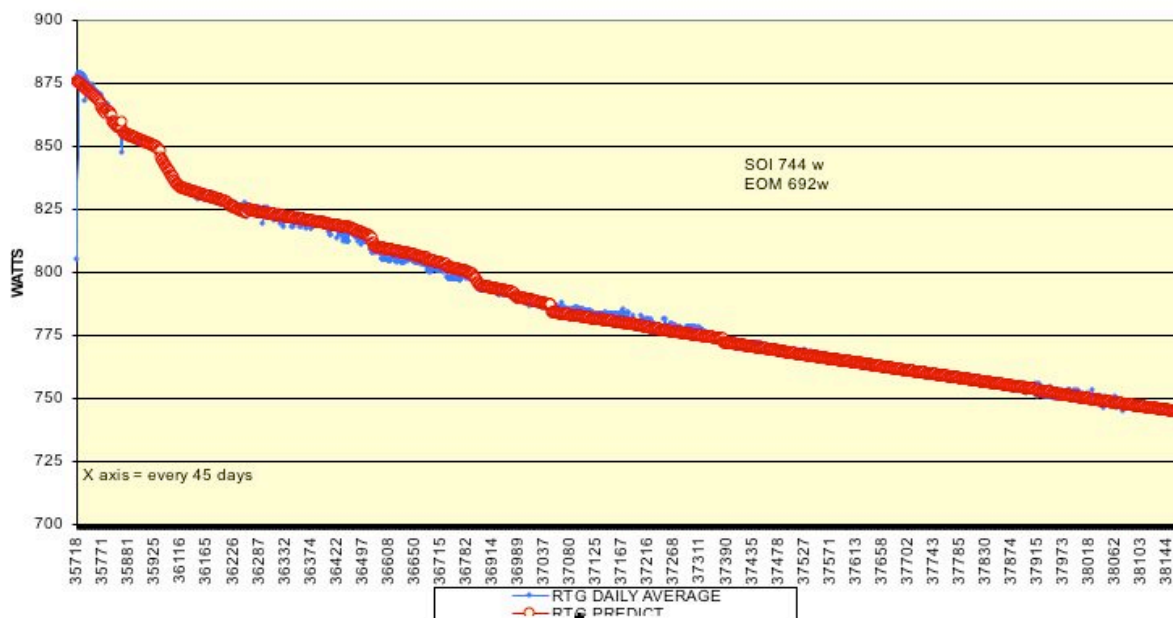

Figure 11. Total Power Output of the Cassini GPHS-RTGs (F-2, F-6, and F-7) from 15 October 1997 to 30 June 2004. (Saturn Orbit Insertion, SOI, was 1 July 2004). (JPL)

4.4 New Horizons Power Performance

The 478-kg New Horizons spacecraft was launched on 19 January 2006 on an Atlas V 551 to begin a 9.5-year voyage to Pluto and its satellites. At encounter, New Horizons will characterize and map the surfaces of Pluto and Charon and their atmospheres. A Jupiter gravity assist is planned for February 2007 followed by an interplanetary cruise phase from March 2007 to June 2015. The New Horizons spacecraft is scheduled to encounter the Pluto system in July 2015. From 2016 to 2020, it is planned to conduct encounters of Kuiper Belt Objects.

Figure 12 shows the GPHS-RTG power measured at the spacecraft power bus for the first 125 days of the mission. The beginning-of-mission (BOM) power was reported to be 245.7 We at the spacecraft power bus.¹² The power at 9.5 years after launch (Pluto flyby) is predicted to be 200 We (versus a specification number of 191 We).^{5,13} At this time, it appears that the New Horizons GPHS-RTG will meet all of its power requirements giving the human race our first chance to see the last planet close-up.

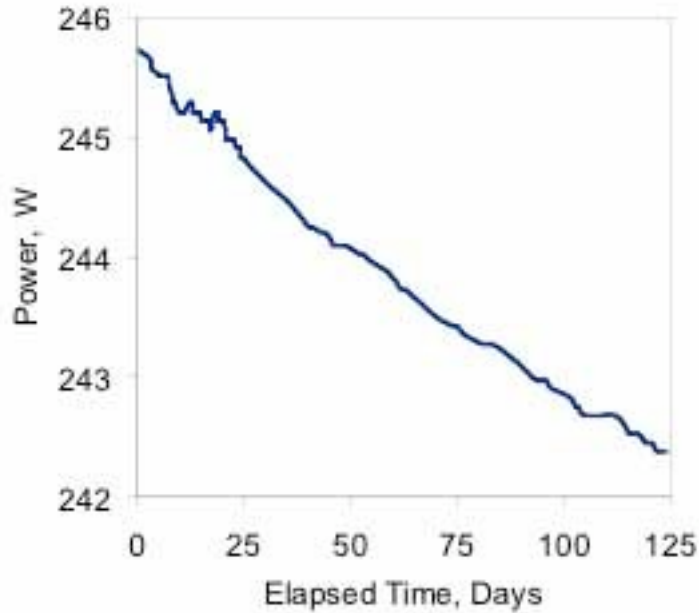

Figure 12. Power versus time plot for the first 125 days of the New Horizons mission.¹²

To give some indication of trends, all of the available silicon-germanium RTG data as of 1994 are plotted in Figure 13.⁴² These data include the reported powers from the Multi-Hundred Watt Radioisotope Thermoelectric Generators (MHW-RTGs) in use on the two U.S. Air Force communications satellites LES-8/9 (Lincoln Experimental Satellites 8 and 9) and the MHW-RTGs in use on NASA's Voyager 1 and Voyager 2 spacecraft. (An instrument failure on Voyager 2 precludes obtaining data on one of the MHW-RTGs; however, from other spacecraft functions it is known that the RTG is producing power.) With corrections for the RTG history and the spacecraft environment (including voltage), these data can be used to approximate the power history of silicon-germanium RTGs. In fact, these data qualitatively support the estimate that F-8 will provide about 200 We for New Horizons when it reaches Pluto.

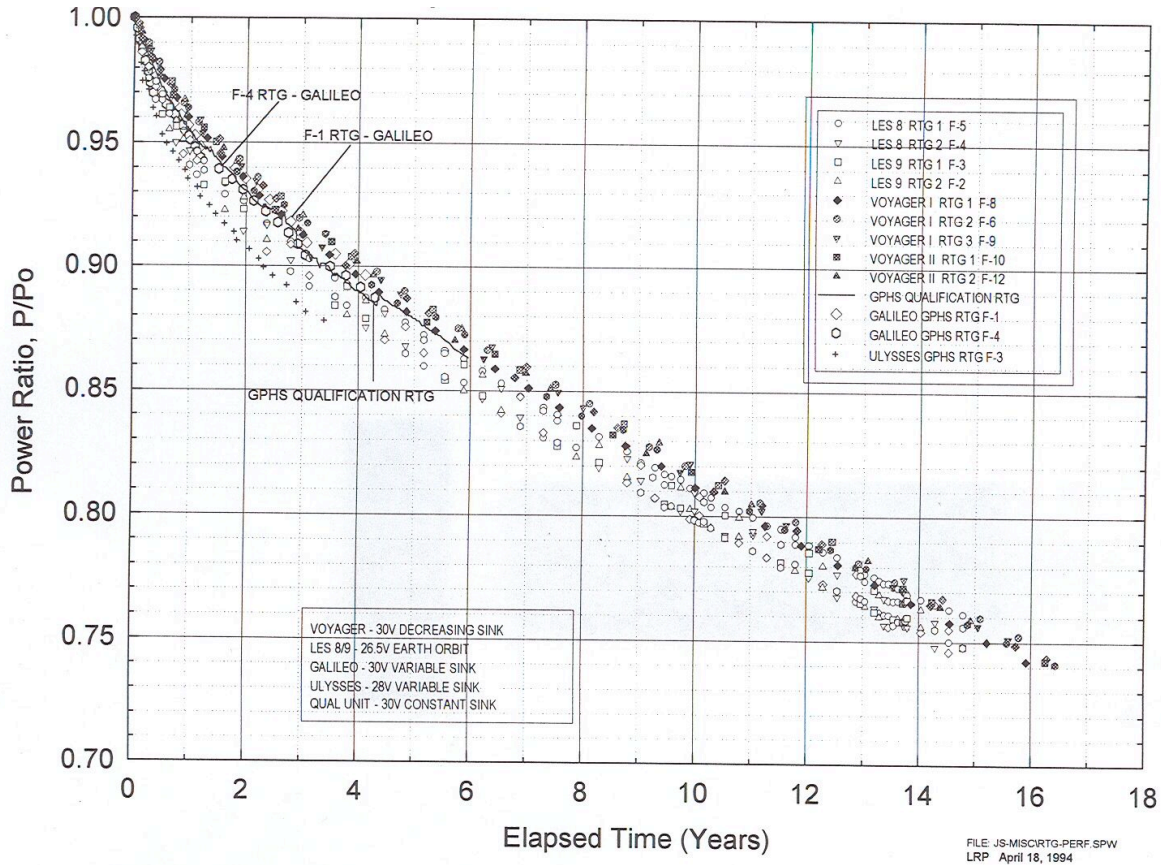

Figure 13. Power histories to 1994 of all silicon-germanium RTGs (MHW-RTGs on LES-8/9 and Voyagers 1 and 2) and GPHS-RTGs on Galileo and Ulysses. For comparison purposes, the data are presented in terms of the ratio of power at each time to the initial power (P_0). Initial powers for the MHW-RTGs ranged from an average of about 153.7 We/RTG on LES-8 to an average of about 159.2 We/RTG on Voyager 2. Initial powers for the GPHS-RTGs, whose launches were delayed over three years, were about 289 We/RTG for Galileo and Ulysses. (JPL)

Conclusions

Seven general-purpose heat source radioisotope thermoelectric generators (GPHS-RTGs) have been successfully assembled, tested and flown on the Galileo (2), Ulysses (1), Cassini (3), and New Horizons (1) space missions. In addition, an Engineering Unit, a Qualification Unit, a flight spare (F-5), and various component-engineering devices were successfully built and tested. All seven flight GPHS-RTGs met or continue to meet all power performance requirements. Thanks to the successful operation of the Galileo and Ulysses GPHS-RTGs, both missions were extended several times (and Ulysses continues to operate). Based on this performance and the extensive database and modeling for silicon-germanium alloy RTGs, it is concluded that the GPHS-RTGs on Ulysses, Cassini and New Horizons will meet or exceed the remaining power performance requirements for those three challenging missions of daring.

Acknowledgments

The authors acknowledge with deep thanks the many contributions made by the staff members of Lockheed Martin Space Systems Company (and its predecessor companies), EG&G Mound Applied Technologies, Savannah River Plant and Laboratory, Los Alamos National Laboratory, Oak Ridge National Laboratory, Sandia National Laboratories, Idaho National Laboratory, Ames Laboratory, Orbital Sciences Corporation (formerly Fairchild Space Company), NUS Corporation, the Johns Hopkins University Applied Physics Laboratory, Westinghouse Hanford Company, and Battelle Columbus Laboratories in the design, analysis, fabrication, and testing of the GPHS-RTGs and their components. In the preparation of this paper, the authors would like to thank Yale Chang and Geoffrey K. Ottman of JHU/APL, Timothy Hoye (LM), Ed Howell (formerly of Mound) and Stephen G. Johnson (INL) for their constructive comments. In particular, we thank Mr. Ottman and Mr. Hoye for sharing their New Horizons F-8 data with us.

Dedication

The authors respectfully dedicate this paper to the memories of those members of the GPHS-RTG team who are no longer with us: William J. Barnett (DOE), Wallace (Wally) H. Boggs (RTI), S. E. Bronisz (LANL), James R. Coleman (JRC), Marshall B. Eck (Orbital), Henry (Hank) Firstenberg (NUS), Donald E. Friedline (Mound ret.), Elizabeth M. Foltyn (LANL), Col. John P. Joyce (USAF ret.), George M. Marmaro (NASA/KSC ret.), Dudley G. McConnell (NASA HQ), Alfred L. Mowery, Jr. (DOE ret.), George H. Ogburn (DOE ret.), Karl G. Sommer (DOE), and R. E. Tate (LANL ret.). Your generators continue to function!

“A life is never ended until all the lives it has touched have ended too .” (Chinese proverb)

References

¹Schock, A., Shostak, A. and H. Sookiazian, H., “Design, Analysis, and Optimization of RTG for Solar Polar Mission”, *Proceedings of the 14th Intersociety Energy Conversion Engineering Conference*, held in Boston, Massachusetts, 5-10 August 1979. (Also issued as Fairchild Space & Electronics Company Report FSEC-ESD-217-79/164.)

²Cockfield, R. D., Hartman, R. F., and Kelly, C. E., “RTG Power Sources for the International Solar Polar Mission”, Paper 809204, *Proceedings of the 15th Intersociety Energy Conversion Engineering Conference*, held 18-22 August 1980 in Seattle, Washington.

³Bennett, Gary L., “Mission Focus: Successful Management Practices on the Galileo and Ulysses Radioisotope Power Sources Program”, in *Space Technology*, Vol. 17, No. 2, pp. 123-132 (1997). Also Paper IAF-96-R.1.05 presented at the 47th International Astronautical Congress, held in Beijing, China, 7-11 October 1996.

⁴Amos, Wayne R. and Goebel, Charles J., “Assembly of Radioisotope Heat Sources and Thermoelectric Converters for Galileo and Ulysses Missions”, *Space Nuclear Power Systems 1989*, edited by M. S. El-Genk and M. D. Hoover, pp. 25-37, Orbit Book Company, Malabar, Florida, 1992.

⁵Rosenberg, Kenneth E. and Johnson, Stephen G., “Assembly and Testing of a Radioisotope Power System for the New Horizons Spacecraft”, AIAA-2006-4192, 4th International Energy Conversion and Engineering Conference, held in San Diego, California, 26-29 June 2006.

⁶*Final Technical Report, GPHS-RTGs in Support of the Cassini Mission, 11 January 1991 through 30 April 1998*, Document No. RR18, Lockheed Martin Astronautics, Valley Forge Operations, Pennsylvania, August 1998.

⁷Bennett, Gary L., Lombardo, James J. and Rock, B. J., “Power Performance of the General-Purpose Heat Source Radioisotope Thermoelectric Generator” in *Space Nuclear Power Systems 1986*, edited by M. S. El-Genk and M. D. Hoover, Orbit Book Company, Malabar, Florida, 1987.

⁸Bennett, Gary L., Lombardo, James J., Hemler, R. J., and Peterson, J. R., “The General-Purpose Heat Source Radioisotope Thermoelectric Generator: Power for the Galileo and Ulysses Missions”, Paper 869458 in *Proceedings of the 21st Intersociety Energy Conversion Engineering Conference*, Vol. 3, pp. 1999-2011, San Diego, California, 25-29 August 1986.

⁹Cockfield, Robert D., “Qualification of the GPHS-RTG for the Galileo and Ulysses Missions”, Paper 869459, *Proceedings of the 21st Intersociety Energy Conversion Engineering Conference*, held in San Diego, California, 25-29 August 1986.

¹⁰Bennett, Gary L., Whitmore, C. W., and Amos, W. R., “On The Development of the Power Sources for the Ulysses and Galileo Missions”, in *Proceedings of the First European Space Power Conference*, held in Madrid, Spain, 2-6 October 1989 (European Space Agency report ESA SP-294, August 1989).

¹¹Bennett, Gary L., Hemler, Richard J., and Schock, Alfred, “Development and Use of the Galileo and Ulysses Power Sources”, *Space Technology*, Vol. 15, No. 3, pp. 157-174, May 1995. Paper IAF-94-R-1-362 presented at the 45th Congress of the International Astronautical Federation, Jerusalem, Israel, 9-14 October 1994.

¹²Ottman, Geoffrey K. and Hersman, Christopher B., “The Pluto-New Horizons RTG and Power System Early Mission Performance”, AIAA-2006-4029, 4th International Energy Conversion and Engineering Conference, held in San Diego, California, 26-29 June 2006.

¹³Cockfield, Robert D., “Preparation of RTG F8 for the Pluto New Horizons Mission”, AIAA-2006-4031, 4th International Energy Conversion and Engineering Conference, held in San Diego, California, 26-29 June 2006.

¹⁴Cockfield, Robert D., “Engineering Development Testing of the GPHS-RTG Converter”, Paper 819173, *Proceedings of the 16th Intersociety Energy Conversion Engineering Conference*, held 9-14 August 1981 in Atlanta, Georgia.

¹⁵Kelly, C. E. and Ambrose, G. R., “Testing of the GPHS Electrically Heated Thermoelectric Converter”, Paper 829234, *Proceedings of the 17 Intersociety Energy Conversion Engineering Conference*, held 8-12 August 1982 in Los Angeles, California.

¹⁶*Final Report for the General Purpose Heat Source – Radioisotope Thermoelectric Generator Program*, GESP-7209, General Electric Company (now Lockheed Martin Astronautics), Philadelphia, Pennsylvania, 1 February 1991.

¹⁷Kelly, Charles E., “The MHW Converter (RTG)”, in *Record of the Tenth Intersociety Energy Conversion Engineering Conference*, held in Newark, Delaware, 18-22 August 1975.

¹⁸Snow, E. C. and Zocher, R. W., *General-Purpose Heat Source Development Phase I -- Design Requirements*, LA-7385-SR, Los Alamos National Laboratory, Los Alamos, New Mexico, 1978.

¹⁹Snow, E. C., Zocher, R. W., Grinberg, I. M., and Hulbert, L. E., *General-Purpose Heat Source Development Phase II— Conceptual Designs*, LA-7546-SR, Los Alamos National Laboratory, Los Alamos, New Mexico, 1978.

²⁰Schock, A., “Design Evolution and Verification of the ‘General-Purpose Heat Source’”, Paper 809203, *Proceedings of the 15th Intersociety Energy Conversion Engineering Conference*, held 18-22 August 1980 in Seattle, Washington.

²¹Bennett, Gary L., Lombardo, James J., Mowery, Jr., A. L., Bradshaw, C. T., Schock, A., Skrabek, E. A., Bartram, B. W., Englehart, R. W., Conn, D. W., Hagan, J. C., and Zocher, R. W., “Development and Implementation of a Space Nuclear Safety Program, *Space Nuclear Power Systems 1987*, edited by M. S. El-Genk and M. D. Hoover, Orbit Book Company, Malabar, Florida, 1988.

²²Bennett, Gary L., Bradshaw, C. Thomas, Englehart, Richard W., Bartram, Bart W., Cull, Theresa A., Zocher, Roy W., Eck, Marshall B., Mukunda, Meera, Brenza, Peter T., Chan, Chris C., Conn, David W., Hagan, James C., Lucero, Eddie F., and Lutz, Steven A., “Update to the Safety Program for the General-Purpose Heat Source Radioisotope Thermoelectric Generators for the Galileo and Ulysses Missions”, *Space Nuclear Power Systems 1989*, edited by M. S. El-Genk and M. D. Hoover, Orbit Book Company, Malabar, Florida, 1992.

²³*GPHS-RTGs in support of the Cassini Mission, Final Safety Analysis Report (FSAR)*, 4 sets, Lockheed Martin Missiles & Space, Valley Forge Operations, Contract No. DE-AC03-91SF18852, released by the U.S. Department of Energy, 20 June 1997.

²⁴*Final Environmental Impact Statement for the New Horizons Mission*, 2 volumes, Science Mission Directorate, National Aeronautics and Space Administration, Washington, D.C., July 2005.

²⁵Bennett, G. L., Hagan, J. C. and Tantino, D. C., *Evaluating Aeroshell Materials for the MJS/Multi-Hundred Watt Heat Source*, ANSP-M-14, ERDA/DNRA 3060-014, The Johns Hopkins University Applied Physics Laboratory, Laurel, Maryland, July 1976.

²⁶Griffin, Charles D., “Vibration Testing of the Pluto/New Horizons Radioisotope Thermoelectric Generator”, AIAA-2006-4030, 4th International Energy Conversion and Engineering Conference, held in San Diego, California, 26-29 June 2006.

²⁷Ambrose, G. R., Cockfield, R. D., and Kelly, C. E., *Qualification Unit RTG Engineering Report*, GESP 7185, Rev. “C”, General Electric Co. (now Lockheed Martin Astronautics), King of Prussia, Pennsylvania, 21 June 1985.

²⁸Ambrose, G. R., Cockfield, R. D., and Kelly, C. E., *F1 Flight Unit RTG Engineering Report*, GESP 7192, Rev. A, General Electric Co. (now Lockheed Martin Astronautics), King of Prussia, Pennsylvania, 18 June 1985.

²⁹Ambrose, G. R., Cockfield, R. D., and Kelly, C. E., *F3 flight Unit RTG Engineering Report*, GESP 7202, Rev. A, General Electric Co. (now Lockheed Martin Astronautics), King of Prussia, Pennsylvania, 14 October 1985.

³⁰Ambrose, G. R., Cockfield, R. D., and Kelly, C. E., *F4 Flight Unit RTG Engineering Report*, GESP 7199, Rev. A, General Electric Co. (now Lockheed Martin Astronautics), King of Prussia, Pennsylvania, 20 September 1985.

³¹Ambrose, G. R., Cockfield, R. D., and Kelly, C. E., *F5 Flight Unit RTG Engineering Report*, GESP 7193, General Electric Co. (now Lockheed Martin Astronautics), King of Prussia, Pennsylvania, 19 July 1985.

³²Loffreda, John A., “TEG 2: A Modified Version of the LOLLIPOPS Computer Program”, Internal Memorandum PIR ISAO MHW 4663, General Electric Company, King of Prussia, Pennsylvania, 4 October 1973.

³³Kelly, Charles E., Loffreda, J. A., and Lorentzen, R., “Performance Models for the MHW Converter”, in *8th Intersociety Energy Conversion Engineering Conference Proceedings Addendum*, held in Philadelphia, Pennsylvania, 13-16 August 1973.

³⁴Raag, Valvo, “The Time and Temperature Behavior of the Thermoelectric Properties of 78 a/o Si – 22 a/o Ge Alloy”, in *Eleventh Intersociety Energy Conversion Engineering Conference Proceedings*, held in State Lane, Nevada, 12-17 September 1976.

³⁵Stapfer Gerry and Truscello, V. C., “The Long-Term Performance Degradation of a Radioisotope Thermoelectric Generator Using Silicon Germanium”, in *Eleventh Intersociety Energy Conversion Engineering Conference Proceedings*, held in State Line, Nevada, 12-17 September 1976.

³⁶Shields, Virgil, “Long Term Behavior of Silicon Germanium Thermoelectric Converters”, in *Proceedings of the 16th Intersociety Energy Conversion Engineering Conference*, held in Atlanta, Georgia, 9-14 August 1981.

³⁷Chmielewski Art B. and Shields, V., “Computer Modeling of Thermoelectric Generator Performance”, in *Proceedings of the 17th Intersociety Energy Conversion Engineering Conference*, held in Los Angeles, California, 8-12 August 1982.

³⁸Bennett, Gary L., Lombardo, James J., and Rock, B. J., “U.S. Radioisotope Thermoelectric Generator Space Operating Experience (June 1961 – December 1982)” in *Proceedings of the 18th Intersociety Energy Conversion Engineering Conference*, held in Orlando, Florida, 21-26 August 1983. (Also published as “US Radioisotope Thermoelectric Generators in Space” in *The Nuclear Engineer*, Vol. 25, No. 2, pp. 49-58, March/April 1984.)

³⁹Kelly, Charles E., “MHW RTG Performance During LES 8/9 and Voyager Missions”, *Transactions of the Fourth Symposium on Space Nuclear Power Systems*, CONF-870102—Summs., held in Albuquerque, New Mexico, 12-16 January 1987, pp. 197-200, Institute for Space nuclear Power studies, University of New Mexico, Albuquerque, New Mexico.

⁴⁰Schock, Alfred, “Closed-Form Solution for the Effect of Fuel Decay and Thermoelectric Degradation on Output of SiGe RTGs”, in *Proceedings of the 26th Intersociety Energy Conversion Engineering Conference*, held in Boston, Massachusetts, 1991.

⁴¹Bennett, Gary L., Campbell, Robert W., Hemler, Richard J., and Putnam, L. R., “Status Report on Performance of Radioisotope Thermoelectric Generators Using Silicon Germanium Thermoelectric Elements”, AIAA 94-4127, in *Proceedings of the 29th Intersociety Energy Conversion Engineering Conference*, held in Monterey, California, 7-12 August 1994.

⁴²Bennett, Gary L. and Skrabek, E. A., “Power Performance of U.S. Space Radioisotope Thermoelectric Generators, *Proceedings of the Fifteenth International Conference on Thermoelectrics*, IEEE Catalog Number 96TH8169, held in Pasadena, California, 26-29 March 1996.

⁴³Hemler, Richard J. and Cockfield, Robert D., “GPHS-RTG Performance on the Galileo Missions”, in *Proceedings of the Eighth Symposium on Space Nuclear Power Systems*, M. S. El-Genk and M. D. Hoover, editors, held in Albuquerque, New Mexico, 6-10 January 1991, CONF-910116, American Institute of Physics, New York.

⁴⁴Hemler, Richard J., Kelly, Charles E., and Braun, James F., “Flight Performance of Galileo and Ulysses RTGs” in *Proceedings of the Ninth Symposium on Space Nuclear Power Systems*, M. S. El-Genk and M. D. Hoover, editors, held in Albuquerque, New Mexico, 12-16 January 1992, AIP Conference Proceedings 246, American Institute of Physics, New York.

⁴⁵Hemler, Richard J. and Kelly, Charles E., “Flight Performance of Galileo and Ulysses RTGs” in *Proceedings of Tenth Symposium on Space Nuclear Power and Propulsion*, M. S. El-Genk and M. D. Hoover, editors, held in Albuquerque, New Mexico, 10-14 January 1993, AIP Conference Proceedings 271, American Institute of Physics, New York.

⁴⁶Hemler, Richard J., Kelly, C. Edward, Klee, Paul M., and Loughlin, Stephen “Flight Performance of Galileo and Ulysses RTGs”, in *Proceedings of the 28th Intersociety Energy Conversion Engineering Conference*, held in Atlanta, Georgia, 8-13 August 1993.

⁴⁷Bennett, Gary L. and Campbell, Robert W., “Performance of the Radioisotope Thermoelectric Generators on the Galileo and Ulysses Missions”, *Proceedings of the Third European Space Power Conference*, held in Graz, Austria, 23-27 August 1993 (European Space Agency ESA WPP-054, August 1993).

⁴⁸Kelly, C. E. and Klee, P. M., “Cassini RTG Acceptance Test Results and RTG Performance on Galileo and Ulysses”, in *Proceedings of the 32nd Intersociety Energy Conversion Engineering Conference*, Vol. 4, pp. 2211-2216, 1997.

⁴⁹Johnson, K. S. and Cockfield, R. D., “Power and Propulsion for the Cassini Mission”, in *Space Technology and Applications International Forum-STAIF 2005*, Part One, pp. 232-239, American Institute of Physics, New York, 2005.